

MODERN WIRELESS



April

1/-

Vol. IV. No. 3.

Edited by JOHN SCOTT-TAGGART, F.Inst.P., A.M.I.E.E.

April, 1925.

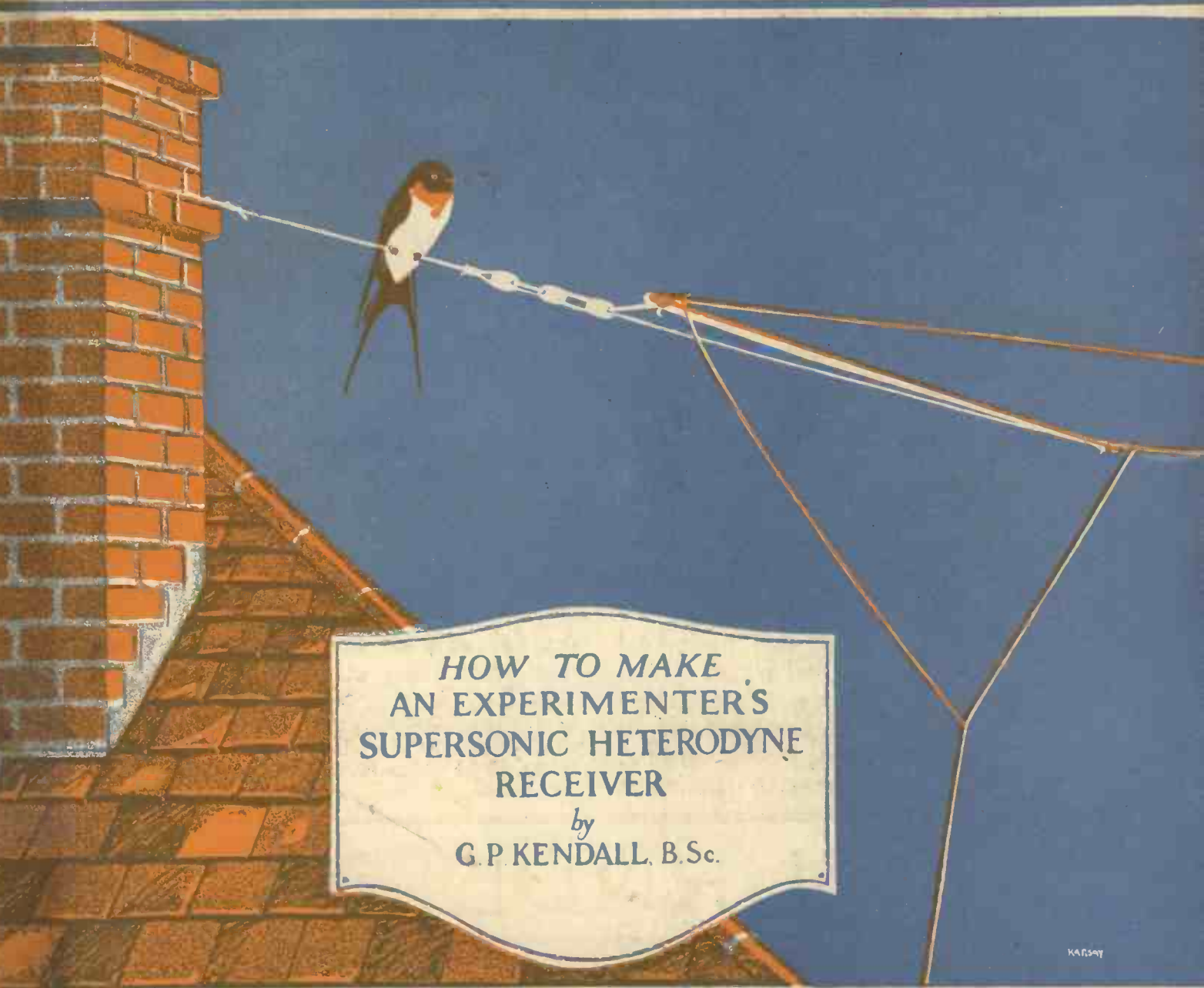

HOW TO MAKE
AN EXPERIMENTER'S
SUPERSONIC HETERODYNE
RECEIVER

by
G. P. KENDALL, B.Sc.

KANSAY

HOW TO BUILD A SENSITIVE THREE-VALVE SET. *By A. Johnson-Randall.*
A CHAT WITH THE NEW CONSTRUCTOR. *By Percy W. Harris, M.I.R.E.*
A MULTI-CRYSTAL RECEIVER. *By A. S. Clark.*
A VISIT TO THE ZURICH BROADCASTING STATION. *By Capt. L. F. Plugge, B.Sc., F.R.Ae.S., F.R.Met.S.*
AN ULTRA-SELECTIVE TUNER. *By John W. Barber.*
BUILDING AN ENCLOSED TWO-VALVE RECEIVER. *By John Underdown.*
A NEW KIND OF SINGLE-VALVE RECEIVER. *By A. D. Cowper, M.Sc.*

CONTINENTAL AND AMERICAN BROADCAST TIME TABLES, ETC.

The Balkite Battery Charger

has no valves or moving parts

THE Balkite Battery Charger enables one to charge accumulators from alternating current in the most convenient manner possible. *It has no valves or moving parts and is absolutely noiseless in operation.* There is nothing to adjust or get out of order.

The Balkite Charger contains a small transformer and a special rectifying cell. When the alternating current passes through, *both* half cycles are converted into direct current for charging the accumulator. The cell contains a rare-metal called Balkite, specially produced for use in the Charger.

When this cell is filled with ordinary accumulator acid the Charger is ready for use and needs no further attention except the periodical addition of a little distilled water.

The appliance delivers a taper charge and cannot discharge, short circuit or damage the accumulator by overcharging. The current drawn from the mains is

very small—about equal to that taken by a 50 candle - power lamp. The charging rate being $2\frac{1}{2}$ to 3 amperes per hour, a 6-volt 50-ampere accumulator will be completely charged in about 20 hours at a cost of less than $\frac{1}{2}$ d. per hour, based on a cost of 6d.

per unit. An accumulator in regular use left once a week to charge overnight will be full up in the morning.

The Balkite Charger has an adapter for plugging into any electric light socket and two spring clips for connection to the accumulator. It is robustly constructed and absolutely

“fool-proof.” Write for full particulars. It should be noted that only one

model can be supplied at present—for alternating current, 200-240 volts, 50-60 cycles.

No. 491. Balkite Battery Charger, 200-240 volts, 50-60 cycles (alternating current) without acid. £5 15 0.

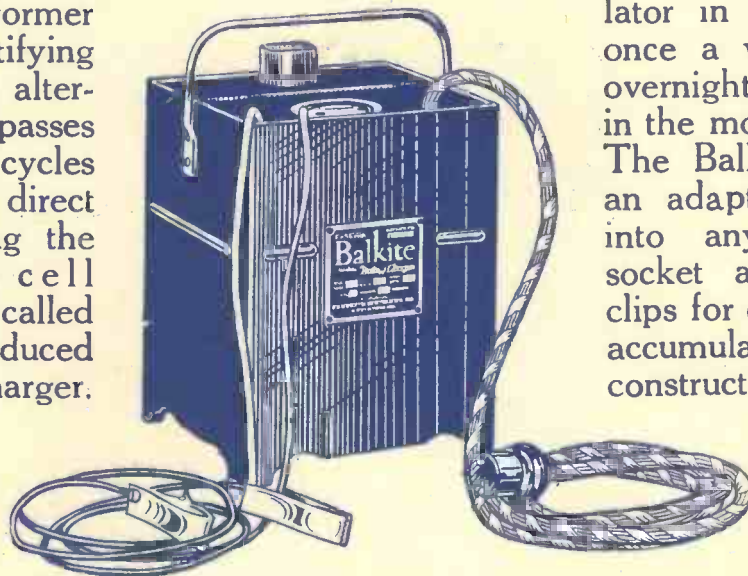

BURNDEPT

WIRELESS APPARATUS

BURNDEPT LTD., Aldine House, Bedford St., Strand, London, W.C.2

Telephone: Gerrard 9072. Telegrams: Burndept, Westrand, London.

LEEDS: 12, Basinghall Street (near City Square). CARDIFF: 67, Queen Street. NORTHAMPTON: 10, The Drapery.

NEW BRANCH: Winchester House, Victoria Square, BIRMINGHAM.

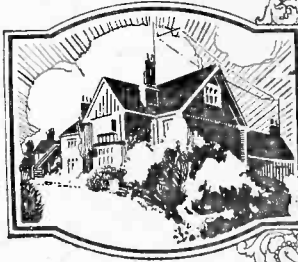

Editor:
JOHN SCOTT-TAGGART,
 F.Inst.P., A.M.I.E.E.

Assistant Editor:
PERCY W. HARRIS, M.I.R.E.

Staff Editors:
E. H. CHAPMAN,
 M.A., D.Sc.
A. D. COWPER, M.Sc.
G. P. KENDALL, B.Sc.
R. W. HALLOWS, M.A.
S. G. RATTEE, M.I.R.E.

Contents

	PAGE
An Experimenter's Supersonic Receiver ...	291
By G. P. KENDALL, B.Sc.	
The Eclipse and Radio Reception ...	297
By G. A. B. ROWE.	
In Passing ...	300
A Drawing-Room Two-Valve Receiver ...	302
By JOHN UNDERDOWN.	
A Chat with the New Constructor ...	307
By PERCY W. HARRIS, M.I.R.E.	
A Split Secondary Tuner for the Experimenter ...	310
By JOHN W. BARBER.	
Regular Programmes from Continental Broad- casting Stations ...	317
The Zurich Broadcasting Station ...	325
By CAPTAIN L. F. PLUGGE, B.Sc., F.R.Ae.S., F.R.Met.S.	
The "General Purpose Three" ...	330
By A. JOHNSON-RANDALL.	
Regular Programmes from American Broadcasting Stations ...	341
A Crystal Set for Comparative Tests ...	348
By A. S. CLARK.	
Trouble Corner ...	357
Using the Potentiometer ...	364
By R. W. HALLOWS, M.A.	
A Simple Selective Set ...	370
By A. D. COWPER M.Sc.	
Tested by Ourselves 378	

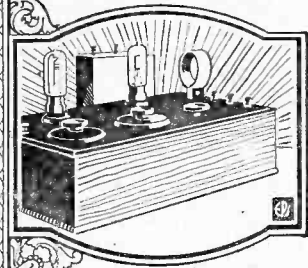

Scientific Adviser:
Prof. G. W. O. HOWE,
 D.Sc., M.I.E.E.

Advisory Editors:
Prof. R. WHIDDINGTON,
 M.A., D.Sc.
Prof. C. L. FORTESCUE,
 M.A., M.I.E.E.

Advertisement Managers:
 BARCLAYS
 ADVERTISING LTD.,
 Bush House, Strand, W.C.2
 Tel.—City 9911.

Radio Press, Ltd.,
 Publishers of "Wireless Weekly" and "The
 Wireless Constructor,"
Bush House, Strand, W.C.2.
 Telephone.—City 9911.



All correspondence relating to contributions is to be
 addressed to the Editor of "Modern Wireless."

Nothing contained herein is to be regarded as permission
 or encouragement to infringe any patent rights.

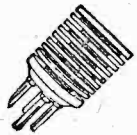

MATCHED H.F. TRANS- FORMERS.

Every one guaranteed to
 match perfectly every other
 in its range. All ranges
 150 to 3,000 metres and up,
 also special Neurodyne Unit.
 Price each 7/-

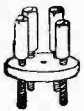

ANTI-CAPACITY VALVE HOLDER.

Through low losses gives
 greatly increased efficiency,
 especially on short wave-
 lengths. Fixed without
 metal nuts and screws. As
 used by Mr. P. W. Harris.
 Price 1/2



NEURODYNE CONDEN- SERS.

Minimum capacity practically
 zero. Low losses make high
 efficiency in tuning neutral-
 ising circuits. One screw
 fixing with $\frac{3}{8}$ " hole for spindle.
 Price 5/-

WRITE FOR FREE LIST.

Send 1d. stamp for
 complete Pocket List
 of all Bowyer-Lowe
 Tested Parts. 36 pp.
 of useful information
 and blanks for your
 own notes.



*"With your good help
 I hear pure music now"*

Distorted, unmusical signals will not occur
 when amateurs realise the importance of
 securing Low Losses in their sets.
 To prove this, simply substitute Bowyer-
 Lowe Square Law Condensers for the con-
 densers you are now using, and notice
 the immediate improvement in the strength
 and rich musical quality of your re-
 ception.
 These condensers have the lowest losses and
 highest capacity ratios yet obtained in

condensers of any type, square law or other-
 wise. In addition to ease of tuning and
 calibration they give increased wavelength
 range. So great is their sensitiveness that
 in many cases they transform into successes
 sets which previously failed.
 Low loss parts mean louder, clearer, purer
 reception.
 All Bowyer-Lowe Parts are made to secure
 the Lowest Losses. Use them in all your
 receivers.

Bowyer-Lowe Tested Square Law Condensers and Low Loss Components.

BOWYER-LOWE CO., LTD., RADIO WORKS, LETCHWORTH.

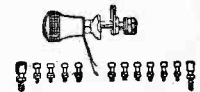

STUD SWITCH PARTS.

Switch Arm, all studs, stops
 and screws, etc., for making
 any switch from 2 to 10 way.
 Drilling template supplied.
 Price 2/3

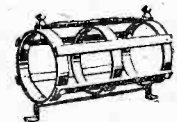

LOW LOSS COIL FORMERS.

For making short wave coils
 with minimum dielectric
 losses. Former is $3\frac{1}{2}$ in. in
 diameter, 6 in. long, with
 terminals and soldering lugs
 each end and bracket for
 fixing. Constructed of Grade
 "A" Ebonite and lacquered
 brass. Price 5/-

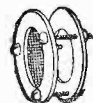

VALVE WINDOWS.

Heavily metal plated, with
 rounded bezel, back plate,
 gauze and all nuts and bolts.
 A handsome finish to any set.
 Price each 9d.

In replying to advertisers, use Order Form enclosed.

Resistance-Capacity Coupling and its merits

RESPONSE OF POLAR R.C.C. UNIT
AT VARIOUS AUDIO FREQUENCIES

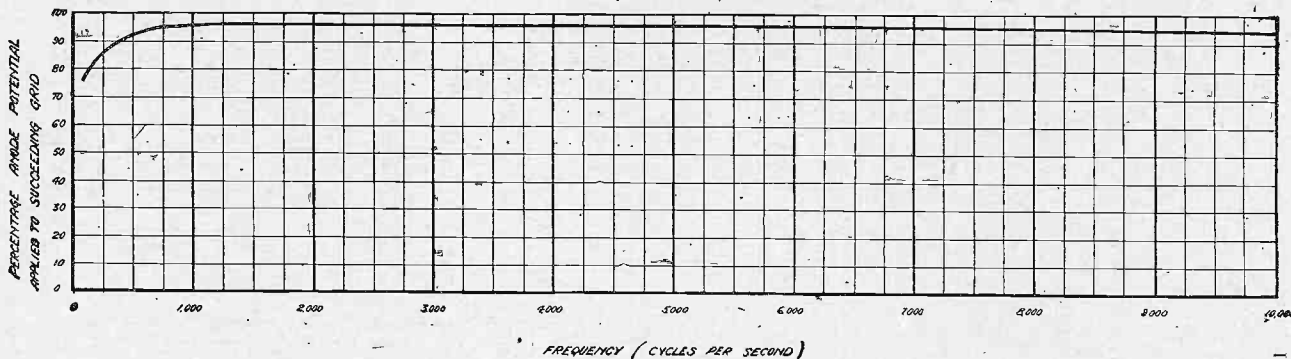

I HAVE not been given as much space as I would like in order to tell you about the merits of Resistance-Capacity Coupling. There are, perhaps, two reasons for this—namely, because I must not weary you, and because space costs money. You must therefore excuse me if these notes lack literary style.

The meaning of distortion in relation to Broadcast is now understood by the time one leaves ones "prep." school. When we say that distortion is present, we mean that the reproduction differs from the original in some way—that is to say, some quality is lacking, or some undesired vibration has been added unintentionally.

How, then, can we ensure faithful reproduction? It is well worth striving after.

There are three main things which can influence "quality"; they are:—

- (a) The valves you use.
- (b) The voltages you use.
- (c) The inter-valve coupling you use.

These are all important, but perhaps the last needs most care.

The purpose of any form of inter-valve coupling is to apply fluctuating voltages to the grid of one valve by virtue of the fluctuations of current in the anode circuit of the valve before it.

An inter-valve coupling is a good one, if, amongst other things:—

- (1) The output voltage is truly proportional to the input current;
- (2) The output voltage for a given input current is the same whatever the audible frequency.

Now it happens that the only way of obtaining fluctuating

voltages from fluctuations of current is by passing the latter through something which impedes its flow.

We call such a thing an "impedance."

There are three things which have "impedance"—namely, an inductance, a capacity, and a resistance.

The impedance of an inductance is proportional to the frequency—it is therefore unwise to use a choke or transformer for inter-valve coupling.

The impedance of a condenser is inversely proportional to the frequency; therefore it would be unwise to use the voltage drop across a condenser, even if a practical arrangement of this kind existed.

The impedance of a resistance is constant for all frequencies, and therefore it is pre-eminently the thing to use for valve coupling.

The impedance of the wire resistance in an R.C.C. unit has a variation of less than 1 per cent. over the frequency range of 100-10,000 cycles per second.

This impedance is, of course, constant for all current values up to twice the safe current carrying capacity.

R.C.C. units therefore fulfil in a remarkably efficient way conditions (1) and (2) above.



The Polar R.C.C. Unit consists of wire-wound anode resistance, grid leak and specially built Dubilier condenser. It is perfectly self-contained, with four clearly marked terminals correctly positioned for easy wiring.

Illustration is five-sixths actual size.

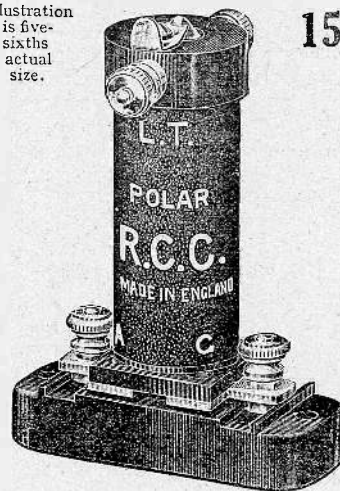

15/-

Norman Hea

Chief Engineer,
Radio Communication Co., Ltd., London, W.C.2.



Radio Communication Co., Ltd., 34-35, NORFOLK STREET, STRAND, LONDON, W.C.2

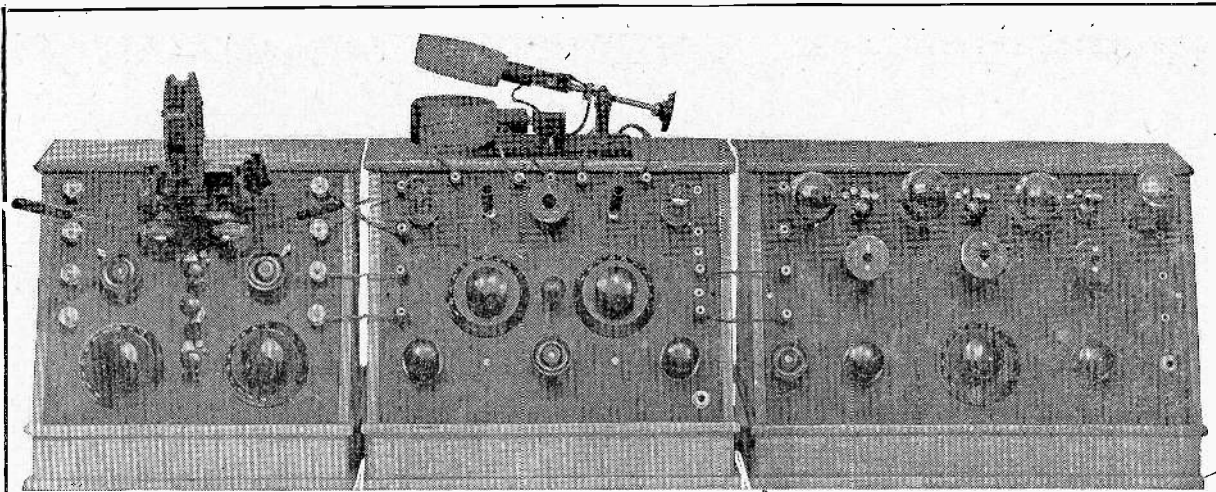

Fig. 1.—A general view of the apparatus showing the units arranged in order.

An Experimenter's Supersonic Receiver

By G. P. KENDALL, B.Sc., Staff Editor.

Although this installation is primarily designed to permit experimental work to be performed upon the super-heterodyne circuit, it gives all the extraordinary results characteristic of a good supersonic receiver. The article, the first section of which appears in this issue, will be found of value to all interested in these circuits, since it deals in a general manner with the practical side of their design and operation.

THE title of this article is intended to convey that the instrument which we shall be considering is not to be regarded as a receiving set specially designed to enable one to switch on, adjust a few dials, and enjoy the programme from certain stations. Actually, the set is intended to provide an extremely flexible super-heterodyne equipment, so arranged as to permit of the carrying out of a great deal of experimental work upon the super-heterodyne circuit, with the minimum of actual reconstruction at each change. I have therefore proceeded upon very different lines from those which would have been followed by the designer of an instrument which was to form a receiving set with a more or less fixed arrangement, as the reader will observe when we come to consider the various units of which the equipment is composed, in detail.

The Need for Experiment

Now, experiment is certainly much needed in the super-heterodyne field, since although the circuits are in quite common use in

America, and they appear to be of fairly satisfactory design in that country, it by no means follows that these designs can be copied by the British experimenter with any reasonable chance of success, since they almost all of them call for special components which are not available in this country, and many are designed to suit special types of valves with characteristics which cannot be matched among those on the British market. The first experimental work may be largely a repetition of that which has already been done in the United States, but it must not be considered a waste of time for that reason, since success with the super-heterodyne depends to quite a considerable extent upon a choice of suitable components, in providing suitable means of overcoming practical difficulties, and so on.

The Crucial Points

Some of the most important points on which experiment is called for in the supersonic circuit are these: there is first the question of the method to be adopted in con-

verting our short wave signals to their long wave equivalent; and a variety of methods offer themselves here, such as the original method, using a completely separate oscillator valve to provide the local high-frequency current to heterodyne the incoming signals, while numerous attempts have been made to combine the functions of the oscillator and first detector valve. This latter is a somewhat difficult undertaking, but quite good results have been obtained, and, of course, one eliminates in this way one of the valves of the receiver. The next important point to which attention should be devoted is the appliance commonly called the intermediate frequency filter, which constitutes the coupling between the "frequency converting" part of the circuit and the intermediate frequency or long wave amplifier.

The intermediate frequency amplifier itself presents a number of problems, the actual choice of interval coupling having the most important bearing upon the quality of the results which you will obtain, and there is here a most fruitful

field for experiment. At the present moment, no doubt, it may be argued that there are no suitable interval couplings on the market, but one of reasonable effectiveness can be improvised with little trouble, and provided that it is possible to make easy comparison, there is no very great difficulty in persuading the intermediate frequency amplifier to give the desired degree of selectivity and amplification. An extremely vexed question is involved in the use of a stage of high frequency amplification at the fundamental signal frequency, that is to say, in front of the first detector valve, and it is desirable to be able to remove this valve from circuit at will, since in my own experience this valve is desirable or not very largely according to the arrangements of aerial and earth which are in use at the time, and according to the particular leanings of the user.

The Circuit

A simplified form of the circuit of the apparatus under consideration is given in Fig. 3, and it will be seen that it gives a form of the "Tropadyne" arrangement, which I have found reasonably successful, and apparently very suitable for general experiments in superheterodyne reception. It is advisable to go through this circuit in some detail.

It will be seen that we have first a tuned aerial circuit consisting of the condenser C_1 and coil L_1 , to which is attached an earth connection and a small aerial of some sort. Across this circuit is connected in the ordinary way a high-frequency am-

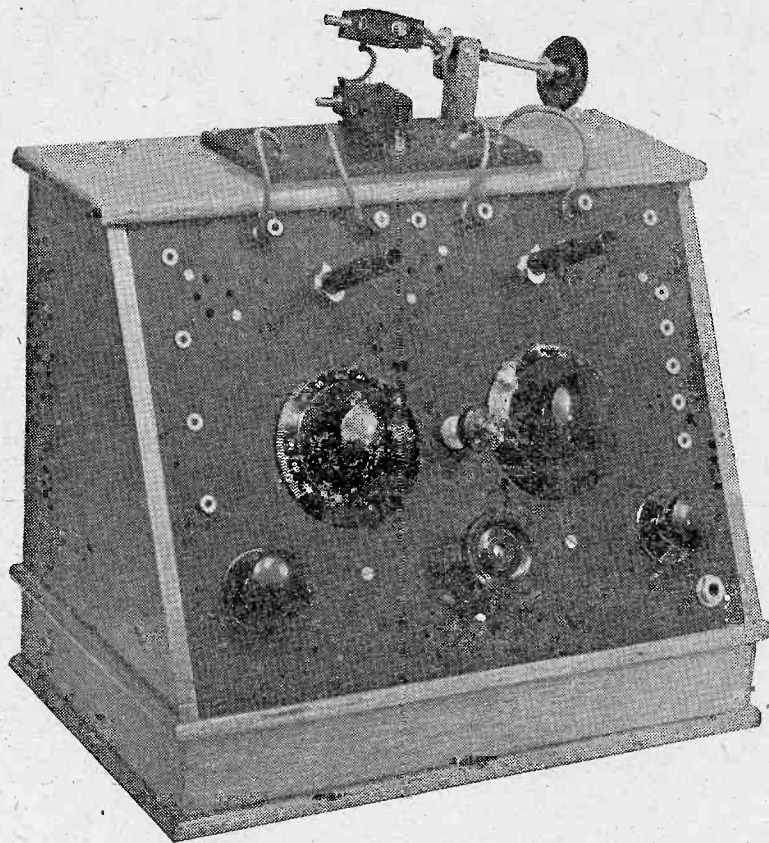

Fig. 2.—The vernier condensers fitted to this unit are "Colverns" with the long handle usually supplied with neutrodyne condensers of the same make. Panel transfers were not used upon this unit simply for the sake of uniformity with the other two, which were built before the great advantages of transfers had been appreciated.

plifying valve V_1 , whose grid potential is controlled by means of a potentiometer, and in whose anode circuit is the primary of the

high-frequency transformer T_1 tuned by the condenser C_2 . This transformer is of the ordinary plug-in variety, any of the standard

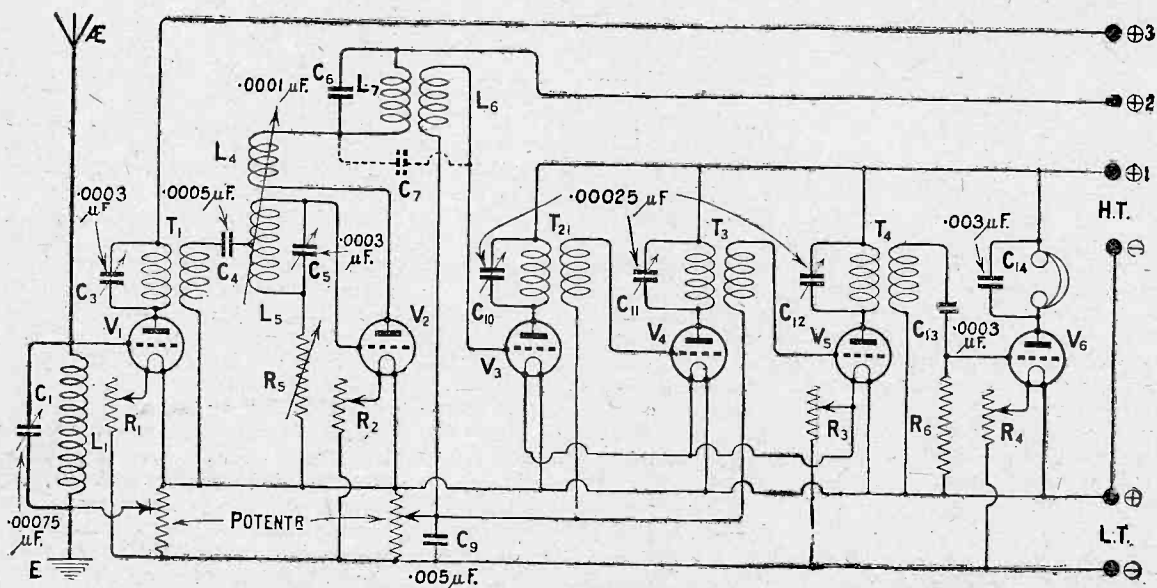

Fig. 3.—A simplified diagram of the apparatus, omitting various details. A full diagram will accompany a later section of this article.

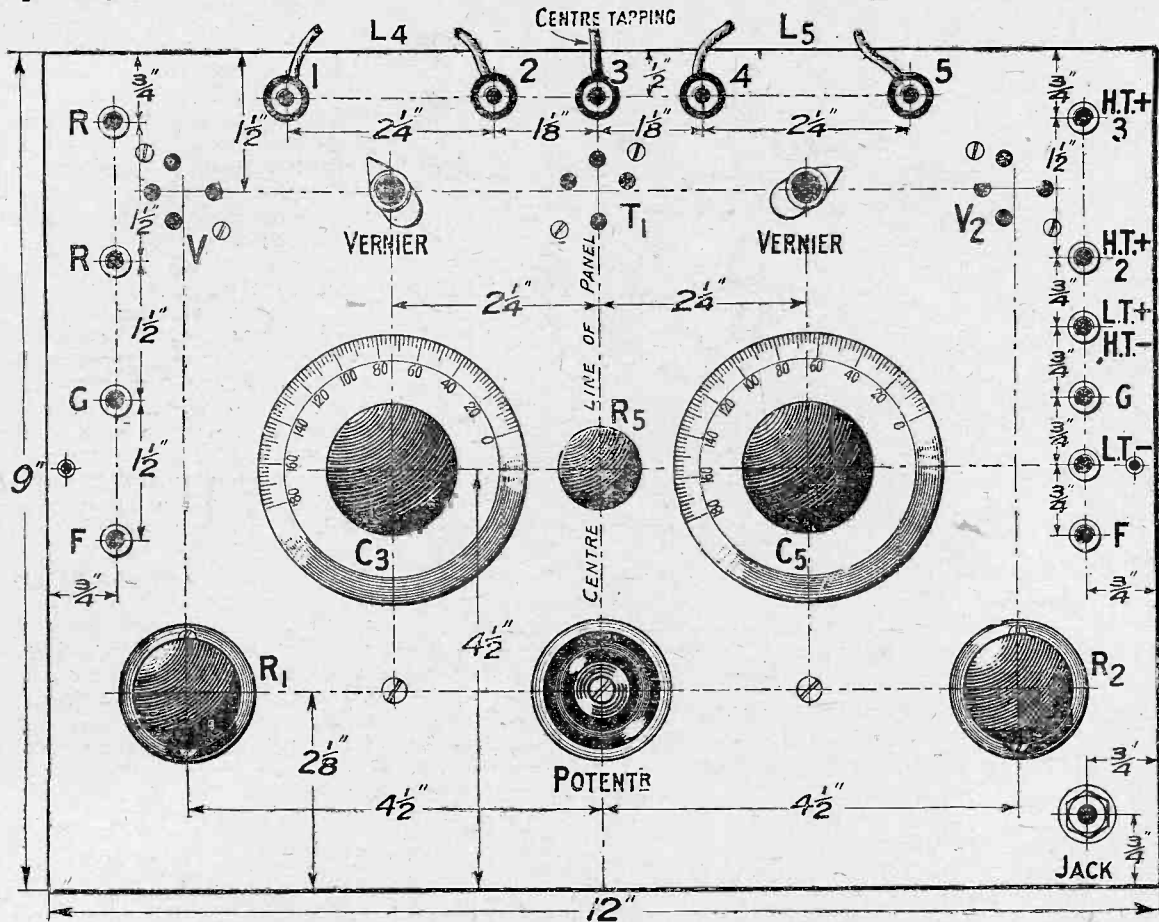

Fig. 4.—The panel layout. A dummy telephone plug with its two elements shorted with a piece of wire is inserted in the jack to turn on the filaments. Blue Print No. 108a.

makes being suitable, and the amplified output from its secondary is applied to the first detector valve, which also performs the function of the local oscillator, so that in its anode circuit beats are produced corresponding to the desired long wavelength which is to be handed on to the intermediate frequency amplifier, which consists of the valves V_3 , V_4 , V_5 , and the second detector V_6 .

The combined detector and oscillator valve V_2 has a tuned grid circuit L_5 , C_5 , which is kept in a state of continuous oscillation by the reaction coil L_4 , which is coupled to it in the ordinary manner, and these local oscillations are tuned to such a frequency as will produce the desired high-frequency beats which may correspond to a long wavelength of the order of from 3,000 to 10,000 metres, according to the requirements of the moment. The connections to this tuned grid circuit should be noted with care, since they constitute the important feature of the "Tropadyne" arrangement, which enables one to use a grid circuit tuned in to some wavelength quite close to that

being received, without upsetting the tuning of the preceding circuits, and without any appreciable back transference of this energy to those circuits.

Use of Centre Tapping

This is achieved by taking the lead from the secondary of the

transformer T_1 to the centre point of the winding L_5 , it being claimed by the originator of this circuit that a nodal point is easily located, such that no potential differences between this point and the filament circuit are set up by the continuous oscillations, so that

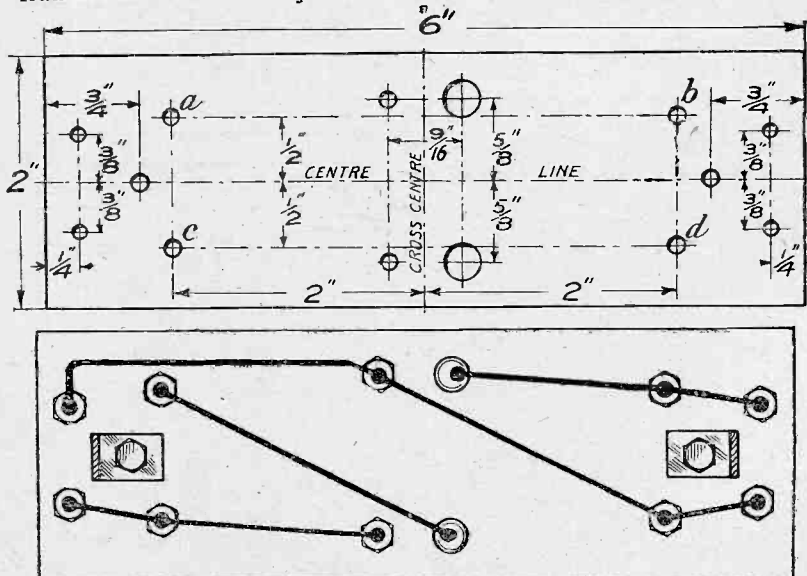

Fig. 5.—The drilling and wiring of the sub-panel.

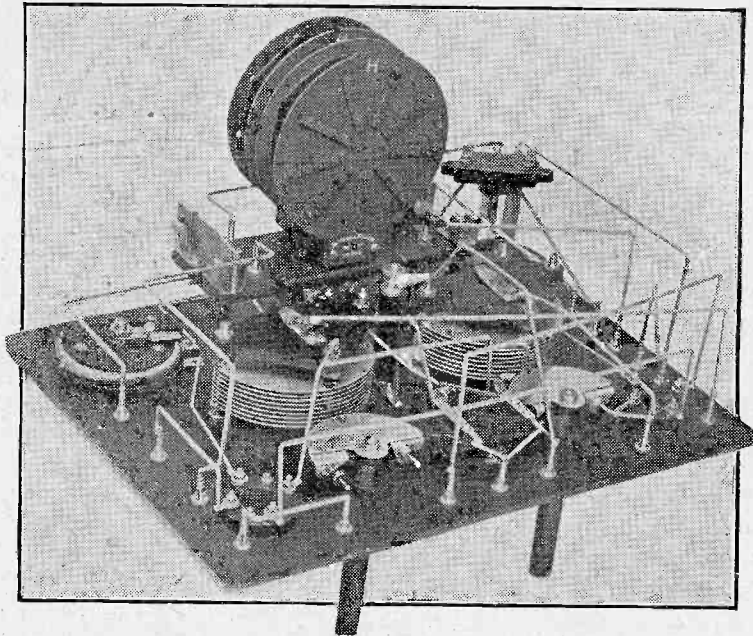

Fig. 6.—This view shows how the sub-panel is arranged. The connections to the left hand vernier are optional.

there is no tendency for energy to be transferred back to the preceding circuit. Certainly, with the aid of a few tappings, and the variable gridleak R_5 , a balance can be obtained which enables the circuit to function quite successfully. The inductance L_5 will, of course, consist of a coil which would normally be of the correct size for a tuned anode circuit to cover the broadcast band, while the condenser C_4 and the leak R_5 may have fairly conventional values.

The Filter

In the anode circuit of this first detector valve V_2 , we have the long wave filter, which consists of the fixed condenser C_6 and the coil L_7 which together give the wavelength to which we desire to alter the frequency of the incoming signals, and coupled to this coil is a secondary winding L_8 which transfers the long wave signals which are built up in the primary winding to the grid and filament of the first of the intermediate frequency amplifying valves, this being designated V_3 upon the diagram. The long wave signals thus transferred to the intermediate frequency amplifier pass through the three successive stages of amplification, and are finally rectified by the valve V_6 in whose anode circuit the telephones are shown. This completes the actual equipment now under description, but, of course, a suitable low-frequency amplifier can be added to enable a loud-speaker to be worked.

Turning now to the actual

apparatus employed, it will be observed from the photographs that there are three distinct sections and these are, upon the left, a standard type of tuner, this being the instrument which I described in the September issue, then a two-valve unit which contains

the first high-frequency valve (which operates at the frequency of the incoming signal), and the "Tropadyne frequency converting" valve, and then in the next unit the three intermediate frequency amplifiers and the second detector. This third unit is the "Experimenter's High-frequency Amplifier" which I described in the February issue.

The Tuner

The tuner employed may be of any good standard type, and it is not necessary to use the somewhat complicated instrument shown, and anyone who desires to try this complete receiver without going to the trouble of making up such a tuner is well advised to use a separate panel containing merely a two-coil holder and a single variable condenser, with terminals upon the left for aerial and earth, and upon the right for the leads to the grid and filament of the first high-frequency valve, and above these a pair which may go to the moving coil socket for reaction purposes under certain special conditions which we shall consider later.

The components which will be required are as follow:—

- 1 Cabinet (Scientific Appliances).
- 1 Ebonite panel, 12 in. by 9 in. by $\frac{1}{4}$ in.

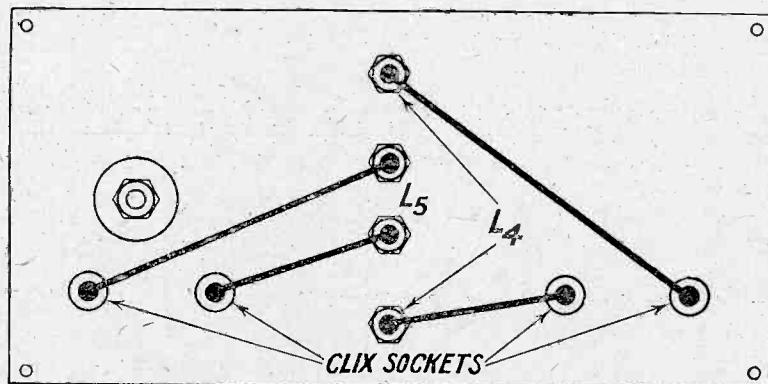
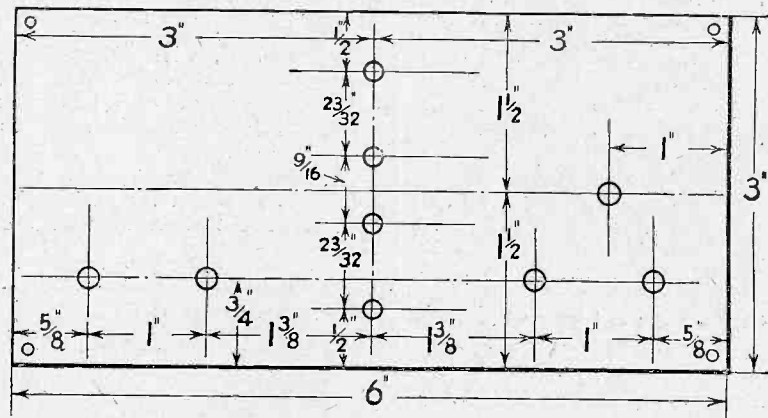

Fig. 7.—The drilling and wiring of the coil-holder panel.

- 1 Ebonite panel, 6 in. by 3 in. by $\frac{1}{4}$ in.
- 1 Ebonite panel, 6 in. by 2 in. by $\frac{1}{4}$ in.
- 2 .0003 μ F variable condensers (Bowyer Lowe).
- 2 "Colvern" condensers with long handles.
- 1 Variable grid leak (Bretwood).
- 2 Filament rheostats (Burndept duals).
- 1 Potentiometer (Sterling).
- 3 Valve sockets (H.T.C.).

1 or more McMichael clip-in condensers (see text).
 One set Radio Press Panel Transfers.
 Referring back to the photograph, Fig. 1, it will be seen that this centre unit contains the first high-frequency valve and the first detector with the necessary filament rheostats for those valves, and also a potentiometer to control the grid potential of the first high-frequency valve, with the necessary plug-in high-frequency transformer and its primary

around the edges of the panel for cross connections between the tuner upon the left, and the intermediate frequency amplifier on the right, and the coil holder upon the top.
 The coil holder itself is mounted upon a small separate panel of ebonite, whose dimensions are given in another diagram, this little panel being let into the top of the cabinet, a suitable piece of wood being cut out beneath by means of a keyhole saw. The connections from the coil holder are brought out to four Clix which

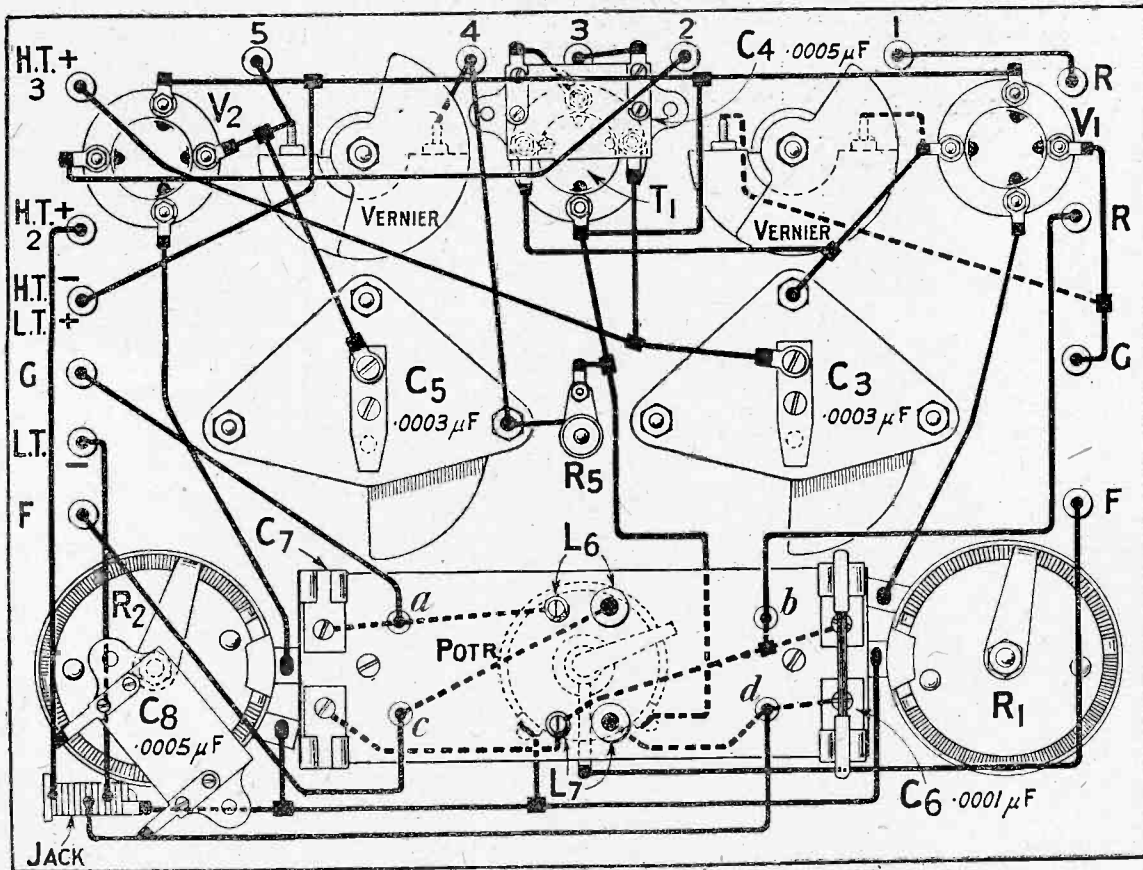

Fig. 8.—The connections on the under-side of the sub-panel next to the back of the main panel are shown dotted. The connections to the potentiometer should be made before the sub-panel is attached. Those of the jack are similar to those given on page 8 of the February issue.

Blue Print No.108b.

- 1 "Single filament" jack (Burne-Jones).
- 19 Clix sockets.
- 1 Universal movement 2-coil holder (Polar).
- 1 .0005 μ F fixed condenser (Dubilier).
- 1 .0005 μ F fixed condenser (Edison Bell).
- 2 Pairs of coil pin and socket mountings.
- 2 Pairs of clips for McMichael clip-in condensers.

tuning condenser, and also the condenser which tunes the grid circuit coil of the combined oscillator-detector, this being the inductance L_5 .
 Two vernier condensers are provided, while upon the top of the cabinet is mounted a two-coil holder of the Polar Universal motion type. This carries in its fixed socket the grid coil L_5 with the central tapping, and in its moving socket the reaction coil L_4 , these constituting the self-oscillating circuits of the valve V_2 . Clix sockets are provided

around the edges of the panel for cross connections between the tuner upon the left, and the intermediate frequency amplifier on the right, and the coil holder upon the top.
 The coil holder itself is mounted upon a small separate panel of ebonite, whose dimensions are given in another diagram, this little panel being let into the top of the cabinet, a suitable piece of wood being cut out beneath by means of a keyhole saw. The connections from the coil holder are brought out to four Clix which

to the centre tapping upon the grid coil L_5 , as will perhaps be seen after inspection of Fig. 1. The right-hand variable condenser controls the tuning of the circuit $L_5 C_5$, that is to say, it governs the frequency of the locally generated oscillations, and it is by its means that one adjusts the frequency of the beats produced, that is to say, the wavelength to which the short-wave signals are converted so that they may be transferred by the filter circuit to the intermediate frequency amplifier. In parallel with this condenser C_5 is a small vernier condenser, whose handle may be seen immediately above, and this I have found most necessary.

The Second Vernier

Immediately above the other condenser will be seen the handle of a similar vernier condenser, and the use of this is optional. The tuning of the primary circuit of the high-frequency transformer T_1 is usually by no means critical, but a vernier across the condenser C_2 may be found useful in some cases. Alternatively, it may be used to produce reaction by being connected directly between the plate and grid of the valve V_1 , as shown in dotted lines upon the wiring diagram. Whether it is necessary in this position or not will depend to a considerable extent upon the aerial used, and upon the very small aerials which are commonly employed, it is quite unnecessary, since the valve V_1 oscillates freely when the potentiometer is turned towards the negative end, a convenient control of reaction being obtained in this way.

The Sub-panel

Upon turning to the photograph showing the inside of this unit, it will be seen that besides the components whose controlling knobs or dials were seen on the face of the panel there is the filter circuit, already referred to, and this is mounted upon a small sub-panel whose dimensions and drilling points are indicated in a further small diagram. Upon this sub-panel there are two pairs of plug and socket mountings for a couple of plug-in coils, these being lettered to indicate that they are to carry the inductances L_6 and L_7 , and also two pairs of clips for McMichael clip-in fixed condensers. These are the condensers C_6 and C_7 , and their position in the circuit will be seen by referring to Fig. 3. C_6 , it will be observed, is merely in parallel with the primary inductance L_7 to adjust

this circuit to the desired wavelength, the power to select any given wavelength, within certain limits, by inserting a suitable condenser being most valuable.

A Coupling Condenser

The other condenser C_7 is not always necessary, and when it is used it occupies the position shown dotted in Fig. 3, that is to say, between the plate end of the coil L_7 , and the grid end of the coil L_6 . Its effect is chiefly to tighten the coupling between the two windings, and whether it will be necessary or not appears to depend largely upon the type of coil used for the coupling, and this matter should be decided by experiment. Since some of the wiring of this dummy panel is below and some of it above the surface of the panel itself, I found it convenient to insert four brass screws, a, b, c, d, through the panel, locking them with nuts above the panel, and certain of the connections are soldered to the heads of these screws, while the leads from the

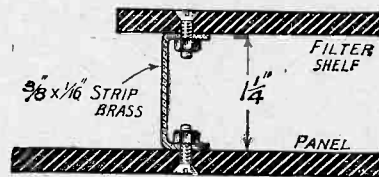

Fig. 9.—One of the packets supporting the sub-panel.

panel to other parts of the circuit are taken from their upper ends.

Upon the wiring diagram it will be observed that the wires beneath this dummy panel are shown dotted, while the full lines denote that the wires are carried above the panel. To take an example, it will be seen that the wire from the screw which secures the upper clip for the condenser C_7 is taken across and soldered to the head of the screw *a*, and then further to the pin of the mounting for the coil L_6 . This wire runs beneath the sub-panel, while the connection from the screw *a* to the Clix socket *G* is taken above the sub-panel. This, no doubt, will be quite clear when the actual wiring is undertaken, although it may appear a little complicated upon the diagram itself.

The Filter Coils

The actual pair of coils which I commonly employ for the long wave filter are a couple of Gambrell H coils which, with a fixed condenser of .0001 microfarad in parallel with the primary coil, give a wavelength which I find to be

extremely convenient in practice. This wavelength I believe to be in the neighbourhood of 2,500 metres, and I use it merely because it is one which is singularly free from long wave morse signals, so that the intermediate frequency amplifier can even be made to oscillate without giving any audible interference, a most valuable state of affairs when it is desired to receive continuous wave signals on the short waves.

The remainder of the construction of the unit itself appears to be quite straightforward, the only point which perhaps calls for mention being the method of mounting the condenser C_4 , this being held in mid-air, as it were, by the two stiff connections which are soldered to its tags from the upper socket of the H.F. transformer T_1 , and from the Clix socket No. 3, respectively.

The reaction coil L_4 may be any standard plug-in type of coil of moderate size, such as a No. 35 of the numbered types, a Burndept S3, or a Gambrell A. The coil with the centre tapping is obviously the most critical component in this part of the circuit, and I have tried a variety of arrangements here with varying success. A decidedly good effect can be obtained by locating a centre tapping upon one of the standard Burndept Concert coils, the S4 being suitable for covering the lower part of the 300-500 metre band, the S5 covering the whole band fairly comfortably with the .0003 μ F variable condenser C_5 which is provided. The making of a centre tapping upon these coils, it must be confessed, is by no means an easy task for the average constructor, and for myself I nearly developed a permanent squint when trying to count accurately the turns of the enamelled wire employed for the S5 coil in order to locate the centre, and I strongly advise anyone else to wind a special coil. This is the more desirable in view of the fact that the electrical centre may not necessarily be the numerical centre turn, and several tappings are desirable in order that the electrical centre may be found by experiment.

The remainder of this article will appear in our next issue, and will contain details of the centre-tapped coil, instructions for operating the set, etc.

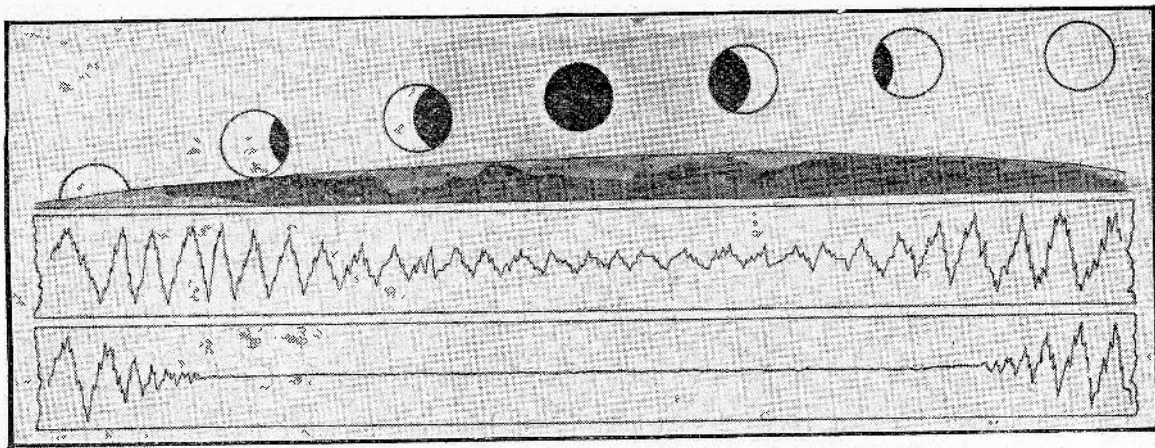

A graphical record of the variations in reception due to the eclipse. The top curve was taken on a wavelength of 380 metres and the bottom one on 75 metres.

The Eclipse and Radio Reception

By G. A. B. ROWE.

Some data concerning the effect of the recent eclipse upon the reception of wireless signals.

THE 24th day of January, 1925, was a date anxiously awaited by scientists in the northern portion of the United States. Formerly the passage of the moon across the sun had been of interest only to astronomers, but this year

it was determined to ascertain what effect the sudden darkness would have upon wireless waves.

It was known that wireless broadcast signals generally became much stronger at nightfall. It was possible to get some idea of how wireless waves travelled by noticing how much stronger they became by night and the extent to which the signals "faded" in and out. It was also possible from such observations to get information as to whether wireless waves travelled along the ground exclusively as "ground waves," or whether they also travelled in part far overhead (as "sky waves") Some scientists think there is good reason to believe that the wave received during darkness for the most part travels at a height of 50 to 75 miles overhead, being reflected back to the ground eventually by a conducting layer of air at that height, known as the Heaviside layer.

To study this effect, both the transmitting stations and the receiving equipment should be in approximately the same straight line running perpendicular to the direction of the shadow of the eclipse. This is so that the degree of the eclipse will be the same at both places at the same time. Also suitable instruments for recording the atmospheric conditions, the power used in transmitting and the condition of the waves as they are received should be provided, in order that any changes in reception may be accounted for.

In New York City, where the

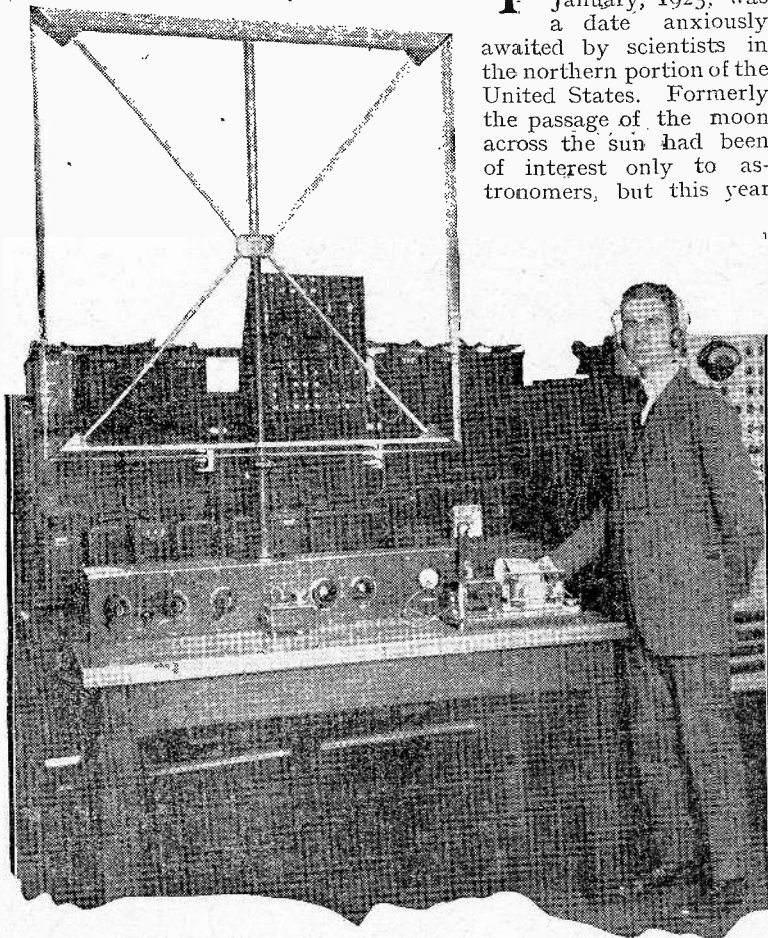

Mr. T. Parkinson, of the American Bureau of Standards, with the recording apparatus he used during the eclipse.

eclipse was total, exhaustive tests were conducted in the laboratory of the Radio Corporation of America. Instruments for recording the amount of "fading" or "swinging" were installed and observations were taken on two wave-lengths from 6.30 a.m. until 11 a.m. for two days before and after the eclipse. Two Super-Heterodyne sets were tuned to signals being broadcast by station WGY and experimental station 2XI, at Schenectady, N.Y., a distance of approximately 160 miles from New York City. Station WGY broadcast on a wave-length of 380 metres and station 2XI sent out signals on a wave-length of 75 metres. The reason for recording a short wave was because this was expected to be reflected more strongly by the shadow wall.

Explanation of Terms Used

It is well known that at night particularly, and over certain distances of 100 miles or more, the received signals are not steady. They will be loud for one moment and then gradually diminish in strength, returning after a while to their original strength. This is called "swinging" or "fading" of the signal and, of course, produces unpleasant reception effects. The usual wave-lengths used in broadcasting—that is, from 220 to 550 metres—do not show much daylight fading effect, although in the early morning hours there is some fading even on these wave-lengths. The shorter waves, those below 100 metres, do show considerable fading effect over certain distances of transmission by daylight.

It is also well known to wireless listeners that there is a marked difference between daytime and night-time strength of signals. The average signal strength at night on the normal broadcasting waves is much greater than the day signals over any considerable distance. On some of the shorter wave-lengths the reverse is the case.

Results of the Eclipse Tests

The following results are more or less preliminary and tentative. They are all subject to later modification, to careful checking of the transmitting and receiving equipment, to make sure that the operation of these devices was constant and correct throughout the tests.

It was found during the five days of the observations that the 380-metre wave was swinging rather badly at sunrise and that the

swinging gradually diminished, the signal becoming steady, as the sun rose higher. As a general rule, the signal became practically steady between $\frac{1}{2}$ hour and $2\frac{1}{2}$ hours after sunrise. The more severe the fading at sunrise, the longer the fading lasted into the daylight hours. Furthermore, the more severe the swinging at sunrise, the more rapid the fading of the signal from loud signals to weak signals and back again.

During the totality of the eclipse it appeared to cause a reduction of swinging of the signals. However, the reduction of swinging apparently caused by the eclipse was not nearly so great a reduction as occurs between night-time conditions and full day-time conditions.

That is, the eclipse did not change swinging nearly so much as does full sunlight. While the above effects were noted, the eclipse did not affect the average signal strength at all. This, during the period of the eclipse, was about the same as it would be in full daylight. During the period of totality it was noticed that atmospheric conditions, which were present before this period, were lessened to a great extent.

Observations on the 75-metre wave during the five days when readings were taken showed that over the distance of 160 miles between Schenectady and New York, this wave had very marked swinging every day, and became weaker towards the middle of the

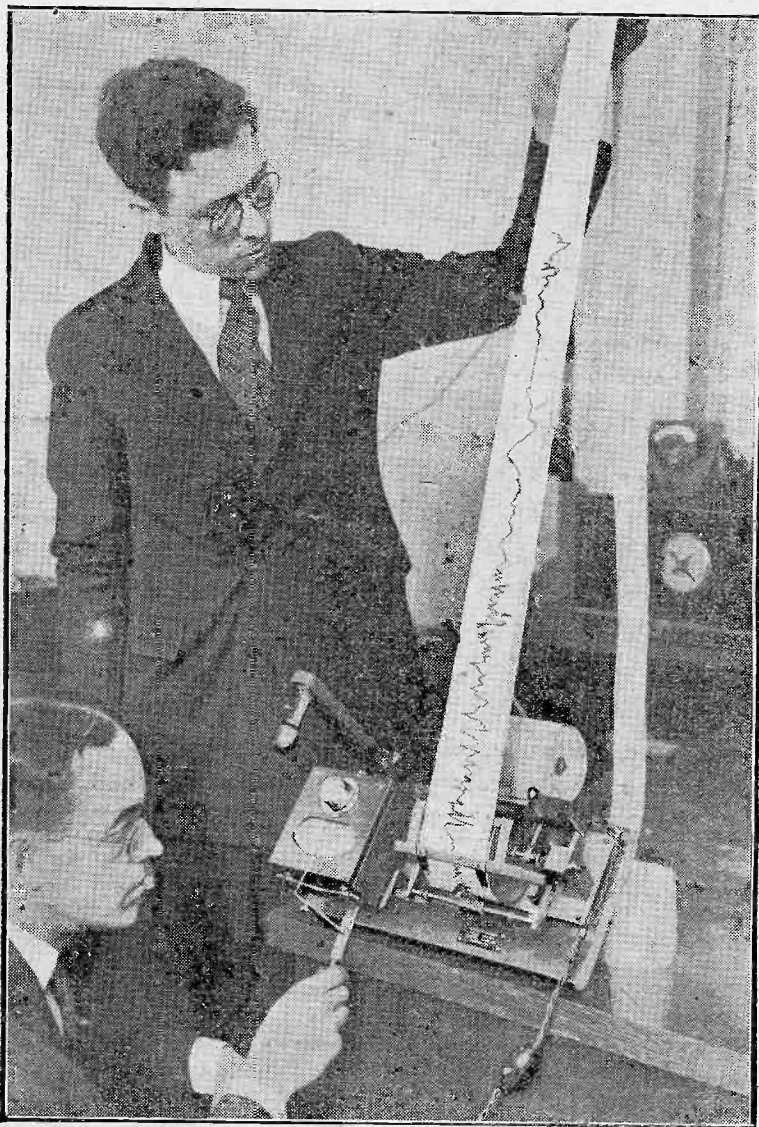

The apparatus used by the Engineers of the Radio Corporation of America, at their laboratory in New York, for experimental work in recording the effects of the eclipse.

day, although it never disappeared for more than a second or two, except during the eclipse period. During the entire period of partial and total eclipse, this wave disappeared altogether. In other words, this short wave is very sensitive to the sunlight conditions on the path over which it travels, and even the partial darkness of the eclipse was apparently sufficient to prevent it from travelling between the transmitting and receiving stations. It was heard loudly before and after the eclipse period.

Conclusions

So far as any general conclusions can be given at this time, it may be said that for transmission over this distance, the normal broadcasting waves were not affected in their average strength by the eclipse, but the swinging was somewhat reduced during the period, thus steadying the wave. The short wave of 75 metres was greatly reduced in intensity during the eclipse; these waves are much more sensitive to changes in illumination of their path than are the longer, normal broadcasting waves. The choice of wave-lengths between 220 and 550 metres for

broadcasting appears to be a fortunate one, and these waves seem on the whole to be the most acceptable for broadcasting purposes. Broadcast listeners need not, therefore, be concerned about any more desirable range of wave-lengths being found for broadcasting than those to which their receivers can now tune, at least so far as the eclipse experiments indicate.

Other interesting effects were observed in the reception of signals transmitted from England on a wave-length of 12,500 metres. These signals were also observed for two days before and after the day of the eclipse. There were two stations in America that were taking readings on these long wave signals, one at Riverhead, Long Island, which was in the path of totality, and the other station was located at Belfast, Maine, which was not in the path of totality. The readings of signal strength that were taken were automatically recorded.

The signal behaviour up to a few minutes before totality was the same as on the previous two days. There was a sharp drop of strength just after dawn and then the usual day-time diminution. However,

just before totality there was another sharp drop in strength which lasted until after the moon had begun its journey off the face of the sun. Then the conditions were approximately the same until the time that the sun was eclipsed to its maximum value in England. At that time there was again a dip in the signal strength curve.

The signals that were recorded at Belfast, Maine, were of a different character in that there was no sharp diminution of strength at the time that the sun was totally eclipsed at the same longitude as the receiving station. However, when the sun had been eclipsed at the transmitting station in England a drop in strength was noted.

Just what these sudden drops in strength mean is impossible to say at the present time, because there has not been sufficient time as yet to check all the data, conditions, etc. The only conclusions so far reached are that the sun has a definite effect on wireless waves. Just what wave-lengths are affected and in what degree is as yet undetermined. As we have mentioned above, these results are preliminary and are merely the effects observed.

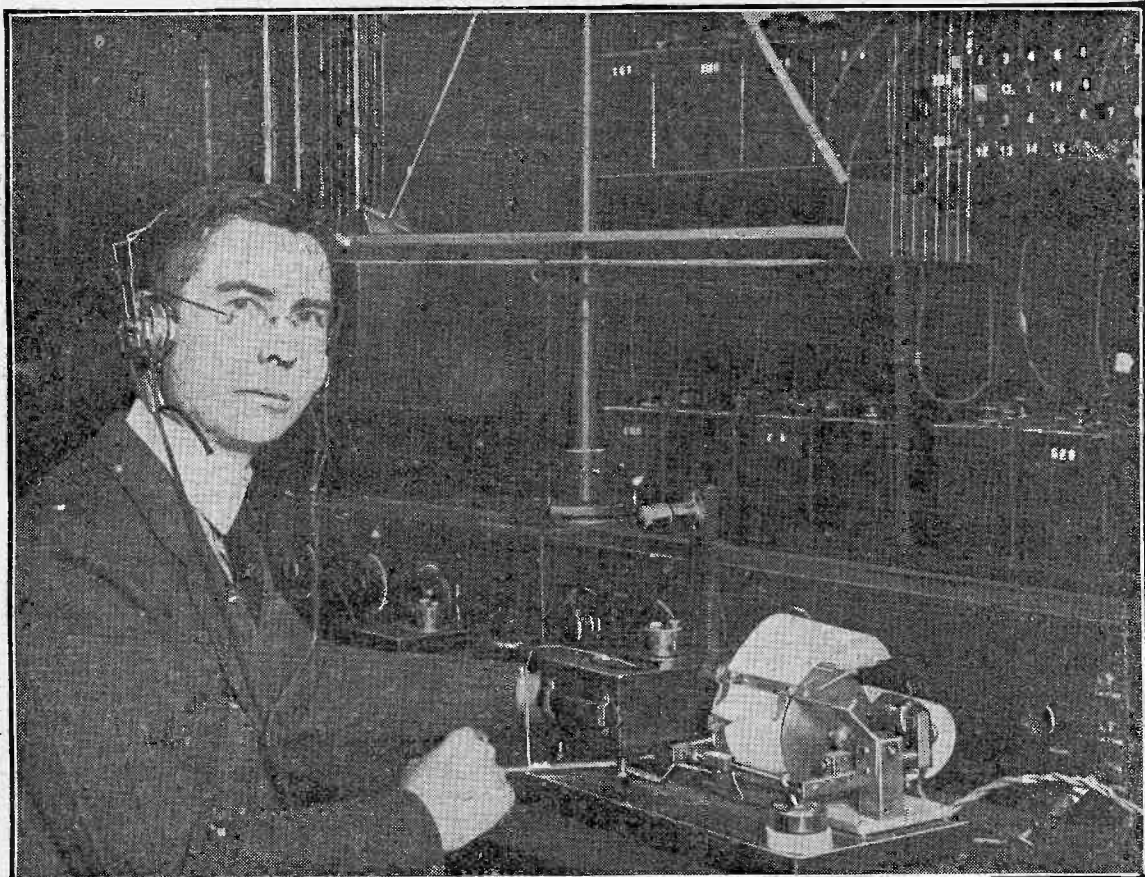

Another view of the special apparatus used by Mr. T. Parkinson at the Bureau of Standards.



Unkind

I HAVE been more than pained to read recently a great deal of unkind criticism levelled against the quality of the B.B.C. programmes which you and I pick up on those nights when Radiating Rupert and others of his kidney are kind enough to allow us to do so. I gather somehow that many people are dissatisfied particularly with the topical talks. Now this is the part of each evening programme which I love above all others. It fills me with the most intense joy to hear Sir Augustus Blunderbore drivelling about pigs, Mr. Elihu Spooer giving his little heart-to-heart talk on how cheese is made, or Professor Blinkowl meandering on upon the subject of wool dyeing. Once the topical talker gets into his stride I close my eyes and lie back in my chair with a little happy sigh. I am happy because I can tell by his voice that he is infinitely more bored than I am. I picture him standing before the microphone with one eye upon his manuscript and the other upon the clock, praying to heaven that his allotted span of twenty minutes may pass quickly.

Reality

I know precisely what happens to him. When the idea of broadcasting was first mooted he was thrilled with the idea of speaking to "a vast unseen audience." He probably felt goosey all over at the thought that his words would be heard not only in Wolverhampton and Wigan and Lerwick and Little Puddleton, but also in Brussels and Paris and possibly Pzuxtrvqmsko. He saw himself scintillating before the microphone. He imagined the joy that he would bring into a myriad homes by his bright and pithy discourse. And then the poor fellow was brought down to earth for the first time with a resounding bump. He was asked to submit his paper typewritten for approval. It is one thing to

let yourself go naturally and quite another to put down your most brilliant sallies in black and white upon paper. It is still another thing when your manuscript comes back with requests for the alteration of certain passages. By the time that the once enthusiastic



One eye on the clock.

broadcaster comes to take his stand before the microphone all the stuffing has been knocked out of him and he is very far indeed from scintillating.

Wonderful

Personally I think that a testimonial signed by all wireless folk should be sent to the B.B.C. to compliment them upon their amazing skill in picking out the dullest subjects and the dreariest talkers that the world has ever known. Do not misunderstand me. I am not throwing bricks. I am handing out compliments as hard as I can. I delight in being bored via the wireless set, simply because I know that I can end the ordeal at any



"Who's been missing his topical talk?"

moment by a single flick of a switch. Also I like being talked to sleep, and I look forward with enormous pleasure to the little nap in which I indulge each evening thanks to

the topical talker. But for him I might suffer agonies from insomnia between dinner-time and bedtime. As it is, I wake at the end of the talk thoroughly refreshed and quite ready to enjoy programmes from the Continent as soon as our own stations have closed down. Whenever I meet a friend who is looking tired and haggard I ask him, "Who's been missing his topical talk?" and once I have shown him the error of his ways he promises never again to omit the little nightly dose. If only the B.B.C. would engage topical talkers up to the present standard to broadcast nightly from one to two "ak emma," I am sure that they would earn the undying gratitude of all confirmed insomniacs.

More Injustice

Then there is the question of the concert party. It appears that quite a number of people strongly object to the elegant form of humour which is broadcast whenever these people are in possession of the studio, largely on the grounds that their jokes are stale. This, I think, is a most regrettable attitude. Being myself a Conservative to the marrow, I am all in favour of the preservation of ancient institutions. To me it seems that the concert party is doing great and noble work in keeping alive a tradition which might otherwise die. But for them all the fine old English jokes about kippers, mothers-in-law, seaside lodgings and Scotsmen might fall into oblivion. No, I would not have the concert party removed from the programmes for worlds. To me they are one of the most precious links with the past that I possess. I love the wobbly and rather strident voices of the sopranos, the nasal tenors and the grunting baritones, for they take one back to the days before the war when music halls were music halls and not palaces of revue. Hot-headed youth may complain that the humour lacks freshness, that the music is not

musical, that the dialogue is rot; but to an old buffer of thirty something the wireless concert party comes like a fragrant breeze from an almost forgotten past. My own memories of pre-war days are still pretty distinct, and there is therefore no need for me to listen to the concert party. It is for this reason alone that I switch off when it comes along, but I trust that my younger friends listen earnestly to it, just as they would to morris dances or old English ballads, for there is nothing quite like it for giving them an insight into the entertainments of many years ago.

More Carping

I am sorry to say there are those who complain that there is too much simultaneous broadcasting. "Why," they say, "should Glasgow or Belfast or Newcastle be compelled to listen willy-nilly to the London programmes? Are these stations incapable of producing something that is entirely their own? And why should London have the monopoly? Why should not Birmingham be simultaneously broadcast two or three nights a week? Birmingham, after all, is somewhere near the middle of the country, whilst London is a mere dot somewhere near the south-east corner." My friends, my friends, do not let your local enthusiasm run away with you. It would never do to turn 2ZY on to S.B., for it is well known that what Manchester thinks to-day London thinks to-morrow, and one simply could not force the pace of thought in the Metropolis in this way. The only way out of this difficulty would be for Manchester to S.B. its yesterday's programme the day after to-morrow. But this is only one side of the question. There is another which is far more important; you must not forget that the B.B.C. realises its enormous potentialities as an educational factor. Thanks largely to the fact that London is responsible for the lion's share of simultaneous broadcasting, the country at large is beginning to speak "Stahndarrrrrd Eenglish." If we were to turn the Northern stations loose, goodness only knows what would happen. Glasgow, for example, would possibly lead us so far astray that before we knew where we were we might be talking "Stahndarrrrrd English." It requires no words of mine to point out what the results might be.

In Praise of S.B.

As for me, I have nothing but praise for the system of simultaneous broadcasting. What I mean

is this. Just as I am settling down to a peaceful evening after dinner there is a ring at the front-door bell and some fellow is shown in who at once expresses a desire to hear all the broadcasting stations one by one. Provided that it turns out to be an evening when S.B. is in progress I can do the trick without the slightest difficulty. So selective is my set on these

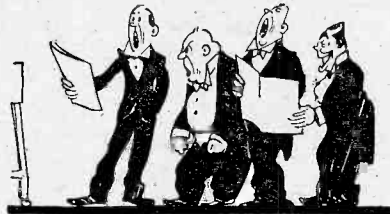

Wireless concert parties.

occasions that I can separate Cardiff from London, London from Manchester, Manchester from Bournemouth, or Glasgow from Belfast. I simply say, "Oh, certainly, delighted," and twiddle the knobs. The tune that we were hearing before now comes in at rather smaller strength. "London S.B. from Manchester," I say with a smile. "Let us see if we can get him a little better." I improve the strength. "Not bad for Manchester," I say. I make a fresh adjustment. "London S.B. from Bournemouth. Perhaps we can get him rather more strongly." We do; and we get all the rest at splendid strength without any trouble at all. "Of course," I say, as the friend listens, usually very much impressed, but occasionally slightly sceptical, "of course it is a pity that there was nothing but S.B. to-night. Still, you heard the other stations at the strength that



"In a Monastery Garden."

they usually come in at on my set. It just shows what a sensitive and selective receiving set can do, does it not? Come round another evening when they are all doing different programmes and let us see what we can make of them then." If the said friend turns up on an evening when S.B. is not in progress it is a most extraordinary thing that my accumulator is invariably on its last legs.

Jazz

Others again are those who run down our admirable programmes by asserting that we have too much jazz. Here, I think, the criticism is most unjust. I welcome jazz for two reasons. In the first place, being without tunes and consisting mainly of a sustained cacophony, it assists enormously in testing out the low frequency part of the set for distortion. The set which will make this kind of thing sound melodious must be indeed as much above suspicion as was Caesar's wife. My second reason is that it is just as helpful as is other S.B. on those nights when a friend who wants too much pays you a visit. In the ordinary way when stations close down at half-past ten he might reasonably ask you to let him hear Breslau and Madrid and Rome and all kinds of other places like that. Provided that jazz is doing its worst you are perfectly safe, for you have merely to point out that as our own stations occupy the entire band between 303 and 495 metres it is quite impossible to tune in the foreigners. "If," you say, "it were a question of the main stations alone, matters would be quite easy; but with these innumerable relays on all kinds of odd wavelengths it is really a matter of impossibility to pick up Continental stations. Come round, my dear fellow, on some night when there is no jazz and you shall hear just what you like from abroad." If he does come you can either work the accumulator stunt already described or you can point to your high tension battery with a little shrug of the shoulders and a despairing wave of the hands.

Just Praise

I think that I have said sufficient to convince you that the B.B.C. programmes as we have them at present are in every way satisfactory, and I hope that in future you will cease to grouse even if sopranos and contraltos bleat and wobble, if alleged tenors sound as though they were suffering from nasal catarrh combined with an effort to swallow a large potato, if you have heard "In a Monastery Garden" so often that even you can play it with one finger, and if the organ at 2, Savoy Hill does sound like an asthmatic concertina. Before you start to grouse remember that good programmes cost money and that the Company's income is still well under half a million a year.

THE LISTENER-IN.

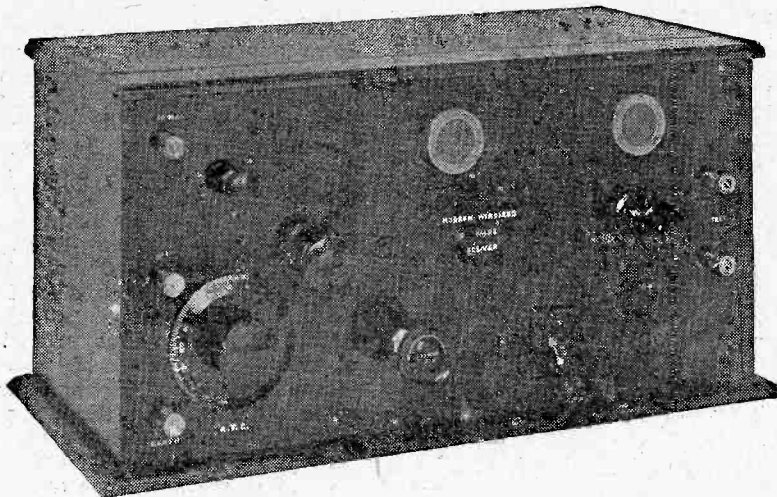

The receiver itself presents a distinguished appearance. On the right is seen the "on and off" switch.

SIMPLICITY and reliability without any sacrifice in efficiency, and a handsome, unobtrusive appearance compatible with the surroundings of a home, are the dominant features of the family receiver about to be described. Coils and valves are enclosed and out of harm's way, whilst once tuned the mere movement of a switch will give the programme from a station—a desirable feature where the set is to be left for the members of the family who do not feel competent to tune even a simple set. Tuning is simplicity itself, one control alone serving to change the wavelength, whilst signal strength may be improved and tuning sharpened by the use of carefully applied reaction, if required. For finer tuning on distant stations a vernier condenser is included. Provision is made for the use of bright or dull emitter valves and separate high-tension and grid bias, so that valves may work under their best conditions for maximum signal strength combined with good reproduction.

The Circuit

The circuit is that of a detector valve using a direct coupled aerial circuit with reaction on it, followed by an efficient stage of transformer coupled low-frequency amplification. Although so simple an arrangement, it is one favoured both by the novice and the long distance worker alike, being frequently used by certain record breaking amateurs noted for their short wave reception. This arrangement is equally suitable for short and long wave working.

Theoretical Arrangement

Referring to the theoretical circuit of Fig. 1, it will be seen that

either constant aerial tuning, with its consequent advantages of improved selectivity and the fact that a given coil will cover a much greater range which can be predicted with a fair degree of accuracy on aerials of widely differing characteristics, or plain parallel tuning may be used by connecting the aerial to the terminal marked "Aerial" or A_1 , respectively. The aerial coil L_1 is tuned by the parallel condenser C_1 of $.0005 \mu F$, whilst the vernier condenser serves for fine tuning on distant stations. Rectification is effected by the usual leaky grid condenser method, the usual values of $.0003 \mu F$ and 2 megohms being used for the condenser and leak. In the plate circuit of the detector valve V_1 are the reaction coil L_2 , coupled to the aerial coil to give magnetic reaction, and also the primary of the low-frequency trans-

**A Drawing-Room
2-Valve Receiver**

by

JOHN UNDERDOWN.

former, from the O.P. of which a tapping is taken to the H.T. +1 terminal to provide a separate supply for this valve. The secondary of the L.F. transformer is connected in the grid circuit of V_2 , and provision is made for grid bias by the small battery G.B. The telephones are in the plate circuit of V_2 , and from one side of these the second tapping is taken to feed this second valve with the necessary high-tension supply. Anticipating a query here, the + telephone terminal is that from which the tapping is taken to the high-tension battery. This will hold good for any set. Two filament rheostats are used, and the switch S in the + filament lead serves to put the set in and out of action.

The Cabinet

From the photographs it will be seen that the set is enclosed in a type of cabinet very popular on account of its neat and convenient form. By lifting the lid

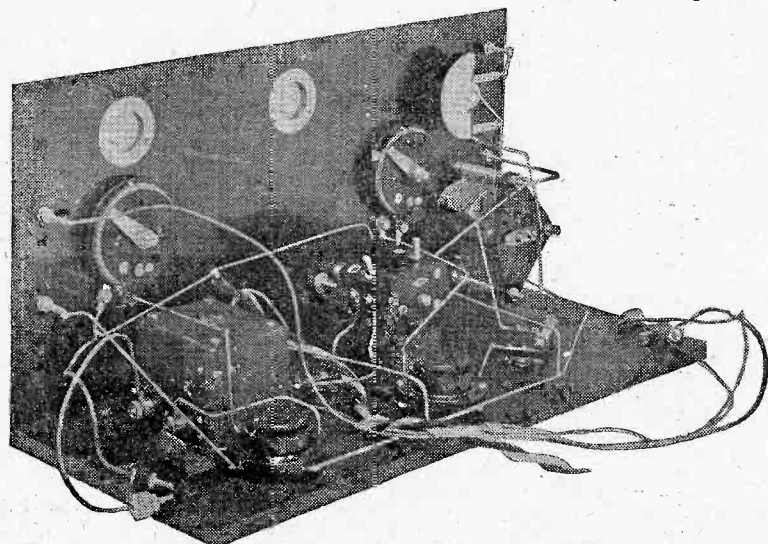

The small clip on the base-board, in the foreground, is for holding the grid battery.

A simple and reliable receiver utilising a circuit effective alike for loud speaker work near a broadcasting station, and for telephone reception at greater distances.

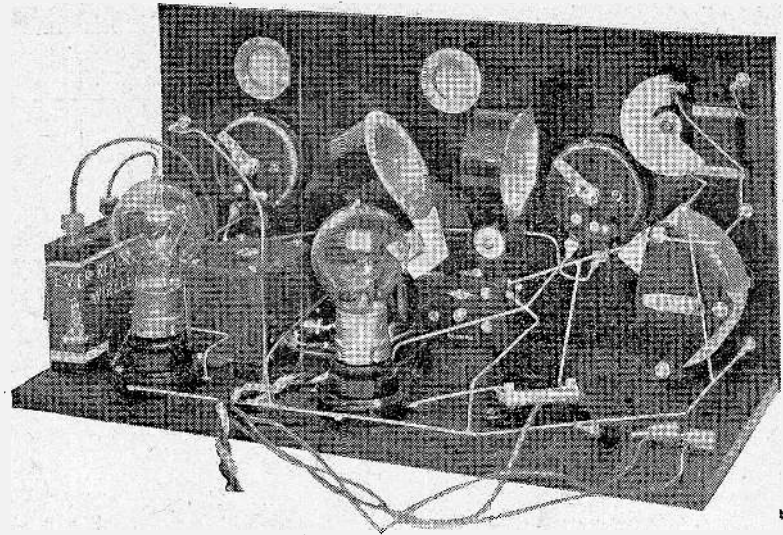

There is ample clearance behind the panel for even the largest coils.

coils and valves are at once exposed and may readily be inspected or changed.

Panel Arrangement

The panel is of polished ebonite, and, with nickelled terminals and valve windows, has a handsome appearance. All the controls are on the front of the panel, the aerial tuning condenser being on the left, and directly above it the associated vernier; the reaction control is in the centre of the panel, and the two filament rheostats are to either side of this latter. Only five terminals appear on the panel, these being the two aerial and earth terminals on the left, and those for telephones or loud-speaker to the right. These are the only terminals in the set, the expedient of taking the battery leads direct to their respective batteries being adopted, thus simplifying construction and wiring.

General Layout

At first reviewing the size of the panel, this seems rather large for a 2-valve set, but will be found necessary in order comfortably to

accommodate the coils behind the panel. Sufficient room has been allowed to use the largest plug-in types of well-known makes and at the same time permit of easily interchanging these. Simplicity has been carefully studied in the behind-panel layout, and a minimum of constructional work will be required. The transformer, valve-holders, the grid condenser, and that of $.002 \mu F$ used as the by-pass across the primary of the former are mounted direct on to the wooden sub-base, so that no valve platform is necessary. To allow of the use of dull emitter valves, some types of which are inclined to be microphonic "Anti-phonic" valve-holders have been used. Where bright emitters or others proved not to have this drawback are used, these may of course be substituted for if desired.

Components Required

To build the set the following

components are required. Makers' names are given so that if desired an exact copy of the set may be made. Although it is obviously not necessary to use the same makes, it should be borne in mind that the arrangement given is of proved success, and if you are in any doubt you will be well advised to adhere to the components used.

- 1 Radion black panel, 16 in. by 8 in. by 3-16 in. thick. (American Hard Rubber Co.)
- 1 Cabinet to take the above panel, with a wooden sub-base 16 in. by 7 in. by 3/8 in. thick. (Carrington Manufacturing Co.)
- 1 $.0005 \mu F$ Square Law condenser. (Bowler-Lowe Co.)
- 1 Colvern vernier condenser. (Collison's Precision Screw Co., Ltd.)
- 1 Behind-panel type of coil-holder. (Peto-Scott, Ltd.)
- 2 Dual filament rheostats and 2 Anti-phonic valve-holders. (Burndept.)
- 1 Connecticut "On and Off" switch. (R. A. Rothermel, Ltd.)
- 1 1st stage L.F. transformer. (Gambrell Bros., Ltd.)
- 3 Fixed condensers type 600 and of $.002$, $.0003$ and $.0001 \mu F$. (Dubilier.)
- 1 Grid leak of 2 megohms. (Dubilier.)
- A length of heavy black and red-covered twin flex. (Any good electrician will supply this.)
- Several yards of V.I.R. flex.
- 5 Nickel-plated terminals. (Burne-Jones, Ltd.)
- 2 Nickel-plated valve windows. (Bowler-Lowe Co., Ltd.)
- Quantity of 16-gauge tinned copper wire and soldering tags.
- 1 Grid bias battery of suitable voltage for the valves used.

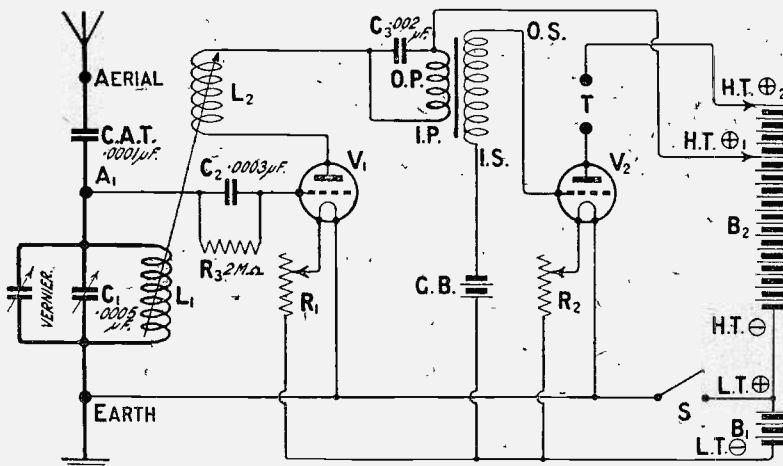

Fig. 1.—The theoretical circuit.

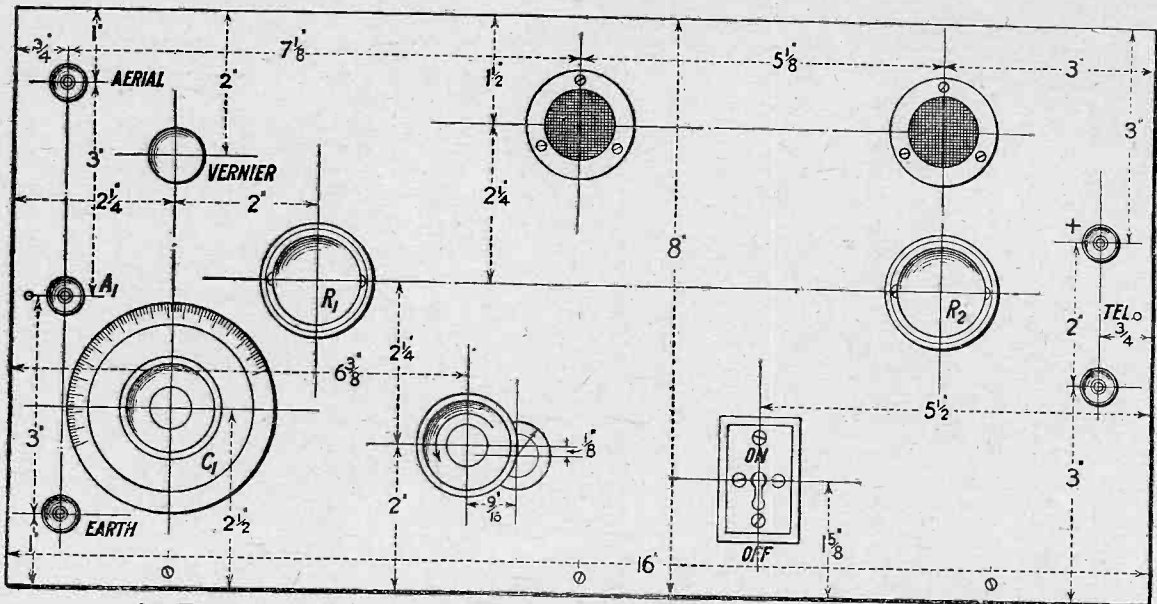

Fig. 2.—The front-of-panel lay out, Blue Print No. 106a, may be obtained from the Sales Department.

That shown is by the Ever-Ready Co., and has a value of 6 volts tapped at $1\frac{1}{2}$ volt steps.

1 Packet of Radio Press panel transfers.

Drilling the Panel

The panel may be readily set out and drilled by consulting the front of panel diagram of Fig. 2. With the original set, the lines on which the various components have their centres were made by using an ordinary carpenter's gauge and a square. With the condenser and filament resistances templates are

supplied, so that no difficulty should be experienced with these. The valve windows are the only problem which may present any difficulty, but if the centres are first drilled with a drill of about the size used for drilling the clearance holes for the terminals, the necessary holes may readily be made by using the ordinary 1 in. carpenter's bit and brace. Drilling should be effected in this case by first drilling from one side of the panel and finishing the hole from the other side, thus making a clean and finished job. With the

polished panel mentioned previously the components may now be mounted, but should unguaranteed ebonite be used it will be necessary to remove the surface skin by rubbing with emery cloth.

Assembling

First fix the valve windows to the panel and then the rheostats and terminals, after which the most convenient step is to mount the .0005 condenser and the vernier, finally completing this part of the construction with the 2-coil holder. It now remains to screw the

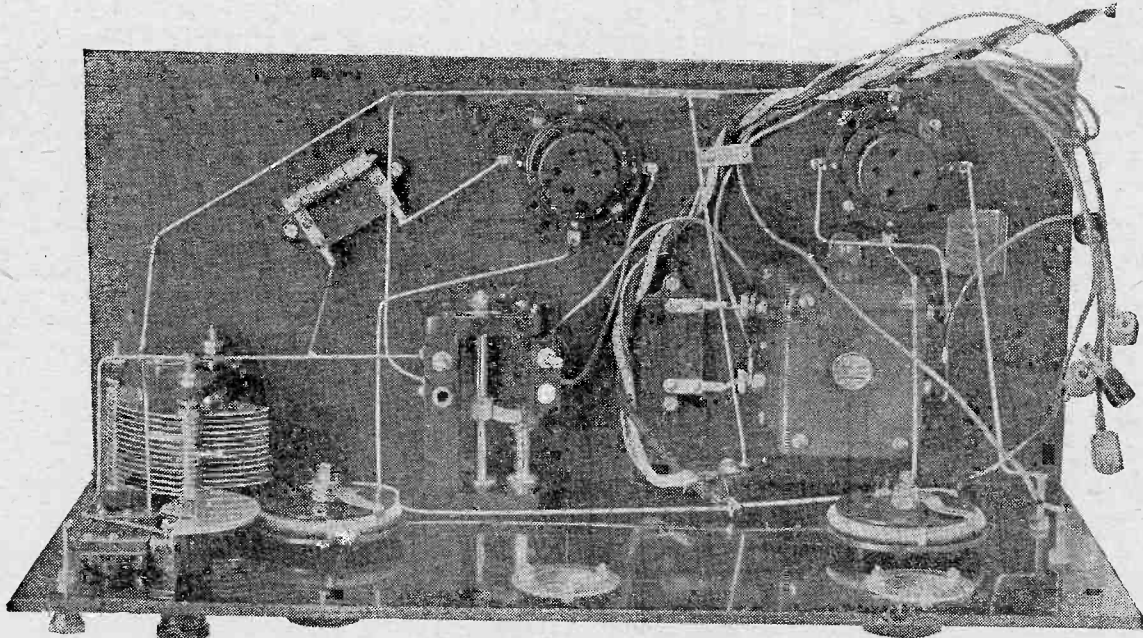

A plan view of the wiring, which should be used in conjunction with the wiring diagram, Fig. 3.

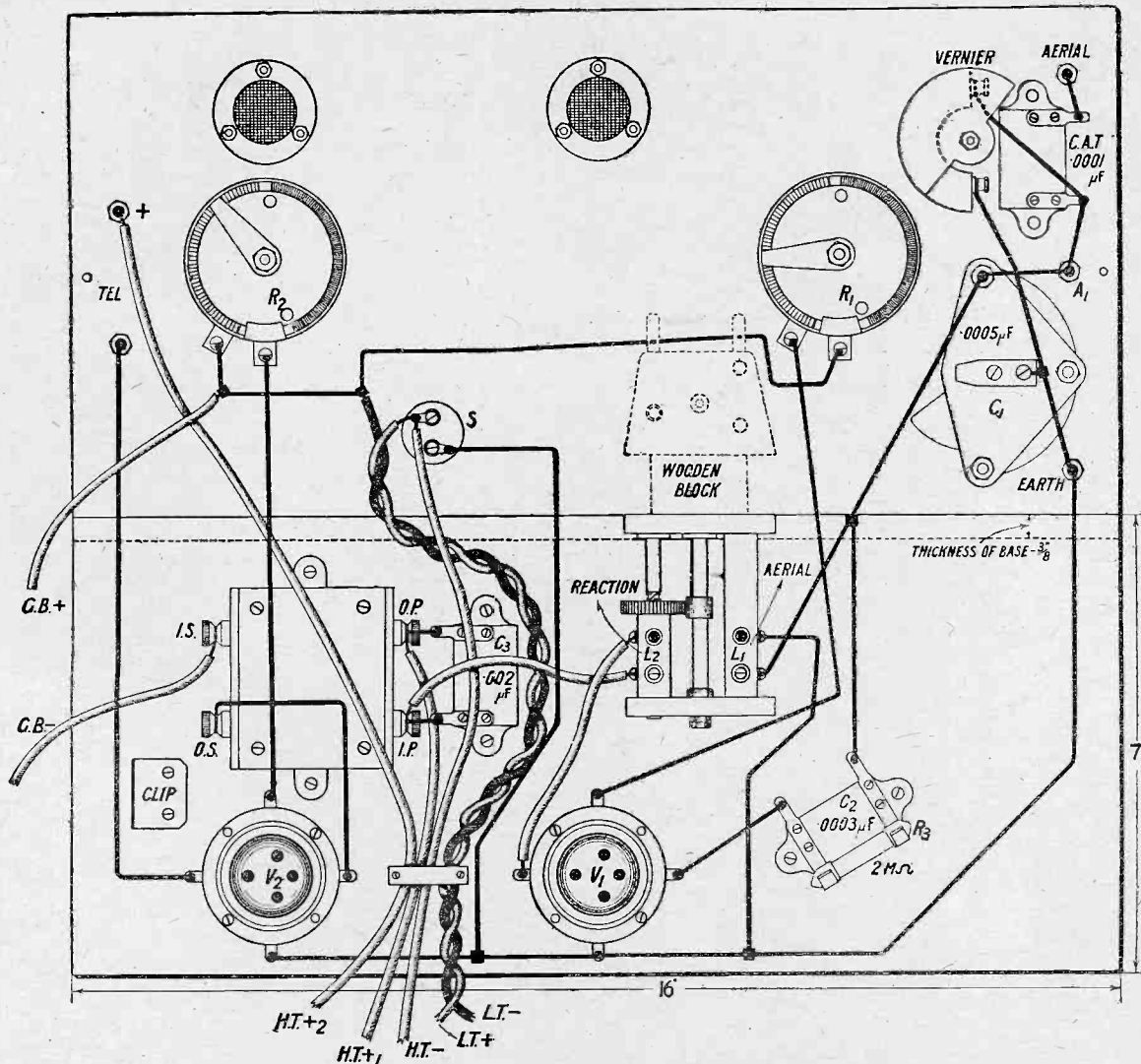

Fig. 3.—The wiring diagram, Blue Print No. 106b. Note that no terminals are provided on the panel for battery leads. Flexible connections are used instead.

transformer, valve-holders and condensers to the sub-base, and this is conveniently effected by referring to the wiring diagram, in which these components are seen in plan. It is advisable at this stage to hold the panel in position against the base to see that ample clearance is left when the former is screwed to the latter. If the layout is followed exactly, ample clearance will be obtained for the largest coils and valves.

Wiring

Before screwing the panel to the baseboard a number of wires may be soldered into position on both with advantage. The tops of terminals, etc., should be carefully cleaned, preferably with a small smooth file, and carefully tinned, when no difficulty should be experienced in making good connections. A really hot iron should be

used and then the connections may be made quickly before nuts become loosened, as usually happens if too cool an iron is employed. A minimum of flux should be used and care taken to remove any surplus which may have splattered on to the panel. Where leads are taken under screws, such as on the rheostats, switch and coil-holder, a convenient method is to use some form of small soldering tags, which can be obtained from any good wireless shop. The panel and baseboard when wired as far as possible are fixed together by three 3/4 in. No. 4 wood screws, no bracket being necessary since when inserted into the cabinet the panel will be held rigidly in position by two further screws, one on each side of the panel, which go into the filets on the side of the cabinet. For the sake of rigidity a conveniently sized piece of 3/8 in. wood may be placed

under the side of the coil-holder furthest from the panel to give support to the coil-holder whilst the coils are being inserted. This should be secured in position during assembly. To hold the grid battery in position a clip can be made out of any convenient piece of thin metal, as seen in the photographs. This should not be fixed until the battery is obtained, but can then be placed to hold the battery against the case. The C.A.T. condenser is held in position by its leads, thus obviating marring the appearance of the panel by using two screws.

Leads to Batteries

To simplify construction the usual terminal strip for H.T. and L.T. leads has been omitted, and these taken direct from the appropriate parts of the circuit. Heavy red and black twin flex has been

used for the L.T. supply, the length of leads being determined by the position in which the battery is to be placed; the same holds for the H.T. leads, which are of V.I.R. flex ended by battery plugs or Clix. These are all brought out together through a convenient hole in the back of the cabinet. Before leaving the set these leads are taken under a small strip of fibre or other insulating material held firmly in position by two small screws. Anticipating a further possible query here, the fact that these leads are bunched together is in no wise detrimental to efficiency, since these are all at earth potential as far as radio frequency currents are concerned, and any capacity introduced does not lead to instability.

Testing

On completion of the wiring the set should be tested. First connect the L.T. battery in circuit and insert a valve in the first valve socket with the switch in the "On" position, but the rheostats off. Now slowly rotate the rheostat, noting that the valve lights correctly. The same test should be carried out with the second valve. Satisfied that the filaments are correctly wired, insert a No. 50 coil in the grid circuit, that is, in the fixed block, and a No. 50 in the moving or reaction socket, and connect the high-tension battery in circuit. For a preliminary test the same H.T. may be used for both valves by plugging H.T. - plug into the minus of the H.T. battery, and the two + plugs into a + socket of a suitable voltage for the valves you are using. Generally a value of 60 volts will be satisfactory for bright emitter valves. Grid bias may be short-circuited during this test by plugging one G.B. Clix into the other. Now connect aerial to the "Aerial" terminal and earth to "Earth" and 'phones between the terminals TEL. With the coils well open rotate the aerial condenser till signals are heard, and then bring the reaction towards the aerial coil, retuning slightly on the aerial condenser. Signal strength should improve and tuning become sharper as this is done till finally, if carried too far, the set oscillates. Previous to this a rushing noise will be heard in the 'phones. Do not work the set up to this point or quality will suffer, and you will tend to spoil reception for your neighbours.

Coils and Valves to Use

For the 300 to 500 metre band a No. 50 will usually be satisfactory,

using C.A.T., or with plain parallel tuning with the aerial connected to A, a No. 35 and 50 will be necessary. For reaction a No. 50 or 75 is required. For 5XX and Radiola a 150, using the A₁ aerial connection, will be necessary for the aerial circuit, and a 100 for reaction.

Any general purpose valves of good make will be suitable for both positions, and the makers' instructions as to H.T. and grid bias should be observed. For loud-speaker work an excellent arrangement is that of a general purpose valve followed by a power valve of the dull emitter type now becoming so popular.

des Postes et Télégraphes, Madrid, Brussels, Radiola and Eiffel Tower, have all been well received. On the very short wavelengths of 100 metres and below, by twisting five turns round the aerial coil, giving an aperiodic aerial circuit, a number of stations were received at fair telephone strength, a concert in French coming in well, after 11 p.m. For this range a Gambrell "a/2" was used for the aerial coil and an "a" for reaction. Under favourable conditions several of the American broadcast stations have been received at fair 'phone strength, among those identified being WGY and WBZ. The set is easy to handle and can be

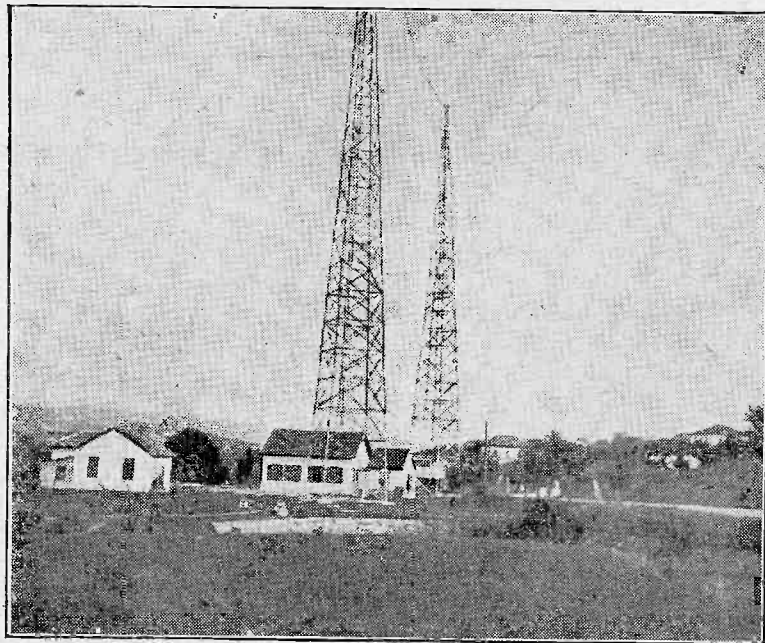

The above photograph shows the new wireless station which is being erected outside Tangiar, Morocco. A single-wire aerial will be employed.

Results

Tested at 12 miles S.E. of 2LO on quite an average aerial, loud-speaker strength was obtained from that station, using a bright emitter as a detector with 60 volts H.T., followed by a B₄ with 100 volts H.T. and about 4.5 volts grid bias; reaction demands were but slight and excellent quality resulted. 5XX also gave excellent loud-speaker results. On 'phones the majority of B.B.C. stations have been obtained at good strength. Of the Continental stations, Münster, sufficiently loud to be read in a small room on the loud-speaker, a number of other German stations, including Hamburg and others unidentified, Petit Parisien, Ecole

well recommended for loud-speaker work within a radius of 10 miles from a main station, though under favourable conditions this may be considerably extended, and for telephone reception at much greater distances.

The May issue of the "Wireless Constructor" will contain full details of How to make an efficient Portable Three-Valve Receiver, by Percy W. Harris, M.I.R.E. Order your copy now.

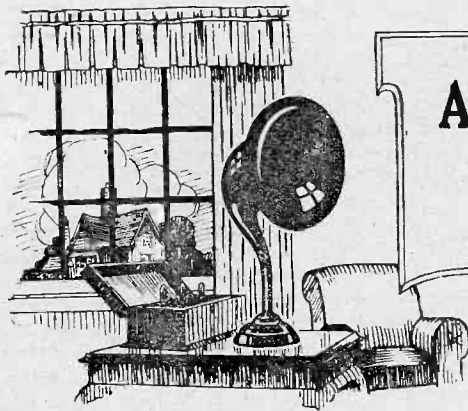

A Chat with the New Constructor

By PERCY W. HARRIS, M.I.R.E.,

Assistant Editor.

Hints and tips for those who are just beginning to build their own apparatus.

THIS issue of MODERN WIRELESS will fall into the hands of many people who, for some reason or other, are just contemplating building their own wireless apparatus, and are wondering just how to set about it. I know from experience just how these affairs start. A general and wide interest in broadcasting and a vague intention of "fixing up a set at home" is suddenly crystallised into a definite desire owing to a visit to a friend's house for some special event, such as the recent Tetraxini broadcast from the London station. In such cases the programme is usually excellent, very well reproduced, and the host for the evening is naturally anxious to point out that the set is "home constructed" at a cost which, to the uninitiated, seems surprisingly low.

Home Construction

At first it seems a rather formidable task to set about building your own apparatus. Quite likely you belong to that numerous class of people which is quite willing to admit that it knows nothing of electricity, has never done any soldering, and is not "mechanically inclined." Yet there is such a big difference between the cost of a properly-constructed commercial set and that of a home-built piece of apparatus that it does really seem worth while to try and build a set for oneself.

Labour Costs

In passing, it is only fair to point out that the big difference referred to does not by any means represent an exorbitant profit on the part of the commercial manufacturer of wireless sets. The amateur and experimenter are apt to overlook the fact that in estimating the cost of a home-built set no allowance whatever is generally made for the time of the home builder. I came across a case the other day which

illustrated this point very well. A young man pointed out with justifiable pride that his excellent set had cost him but twelve pounds, whereas a similar set commercially cost more than twice that figure. The set was built entirely in his spare time in the evening, and it is probable that the equivalent of at least ten full evenings was spent at the work. These evenings did not run consecutively, for on the alternate nights he was working at his office. In a subsequent discussion regarding pay, he pointed out that for this "overtime" he was paid at the rate of time-and-a-half, and he thought that evening work after normal hours should be paid at a higher rate than this.

"If you had been working at the office on those evenings when you were making your set," I asked him, "how much would you

have earned at the time-and-a-half rate?"

"About seven pounds ten shillings," he answered.

"If you had been making wireless sets for your firm," I said, "instead of doing clerical work, that seven pounds ten shillings would have to be added to the cost of the material, while a further sum, probably much more than you would imagine, would have had to be added for establishment charges."

How to Start

There is no need to labour this point. It should be evident to every thinking person that the saving of the labour costs is bound to reduce the cost of production very considerably, and as many people are quite willing to spend their spare time in assembling a set, the popularity of home

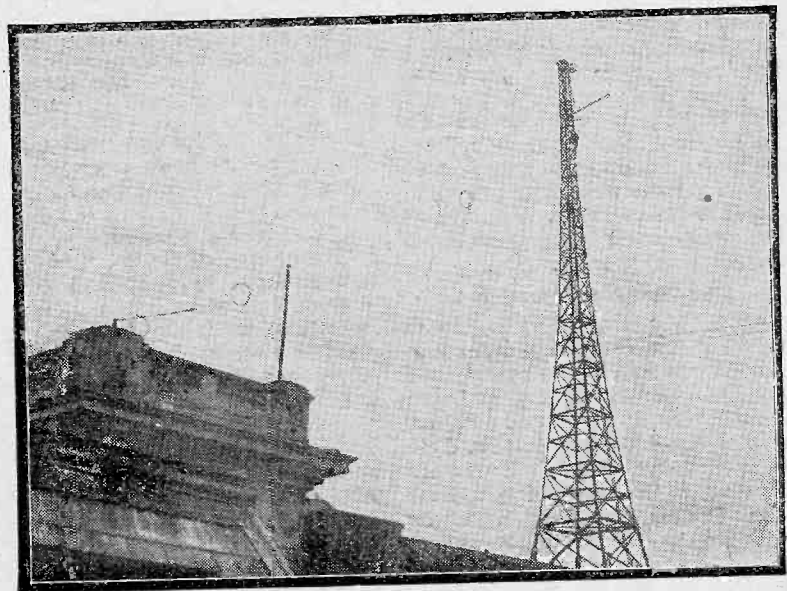

A view of the aerial of the new London station in Oxford Street, which has replaced the existing one at Marconi House.

construction can be well understood.

It is not generally the cost which worries the beginner, but just how to set about building the apparatus. The purpose of this article is to indicate how to make this start, and, after all, a good start is half of the battle.

Commence with a Simple Set

First of all, you must make sure that you really know what you want. You can have anything from a crystal set to an elaborate multi-valve receiver capable of doing all kinds of wonderful things in skilled hands. Unfortunately many beginners, in an excess of zeal, launch out upon the construction of a set both expensive and difficult to manipulate, and when, on completion of the set, they fail to get satisfactory results—or even any results at all—they blame the set, the components, or the paper from which they have taken the design. The position is much the same with cameras. Often you must have noticed that the new photographer purchases a half-guinea camera and takes a number of excellent snapshots. After a few weeks he tires of the limitations of this type of camera and buys an elaborate instrument with a large aperture, anastigmat lens, high speed focal plane shutter, and goodness knows what else besides. To his intense annoyance the family with one voice points out that the results are nothing like so good as he obtained with the cheaper camera, and whatever did he want to spend all that money for? With cameras, elaborate and simple, the position is the same as with wireless sets. An elaborate instrument needs skilled handling and more knowledge than the beginner possesses. If you are just embarking upon wireless as a hobby and are not acquainted with the handling of multi-valve sets, fight the temptation to build a five or six-valve receiver, and, at least for the time being, concentrate on something simpler.

The Humble Crystal Set

The simplest of all to build and by far the cheapest in maintenance costs, as well as in first costs, is the humble crystal set. Do not turn up your nose at the crystal receiver, if you have been accustomed to listening to valve sets. If you are content to listen to the nearest station, and this happens to be within a dozen miles of your home, and if, furthermore, you have facilities to erect an average outdoor aerial, then the crystal receiver properly made, with good quality

headphones, gives all the strength you want in two or three pairs of headphones. If you choose one of the modern, permanent or semi-permanent crystal detectors, such as have been described recently in MODERN WIRELESS, *Wireless Weekly* and the *Wireless Constructor*, you will find that the bugbear of most crystal sets—the need of constant adjustment of the crystal—will be removed. There are no accumulators to buy, no high-tension batteries and no expensive valves. Tested designs for building crystal receivers are published from time to time in

in addition to the detector, while distant stations are brought in clearer if one or more stages of high-frequency precede the detector. What the Radio Press sets will do is always clearly set out in the descriptions published with them, so I need not go into such details here.

Conclusion

A point which needs making perfectly clear to the beginner is that the man who is "always building wireless sets" is not necessarily extravagant. The hobby of wireless is so intensely fascinating that thousands of people are in the

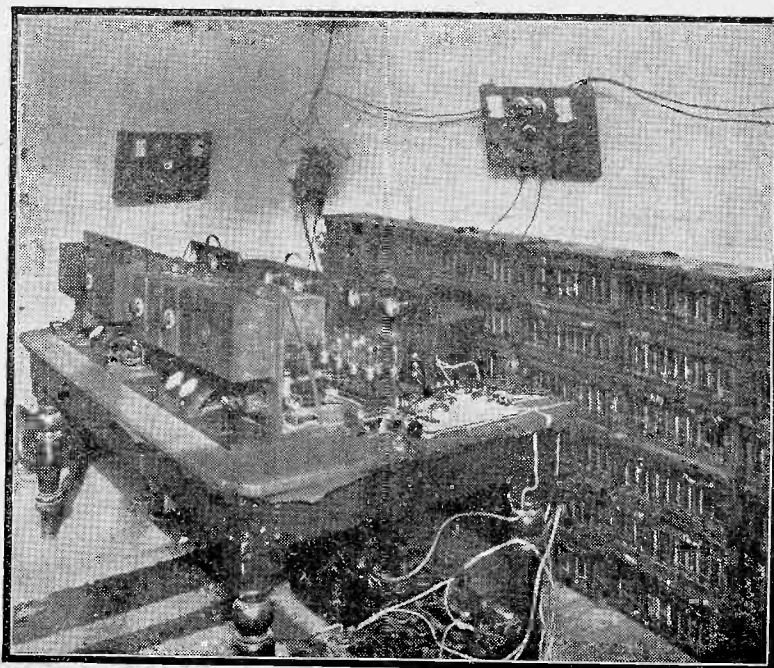

The Marconiphone public speech amplifying equipment which was used in conjunction with the super loud speakers at the Ideal Home Exhibition.

all of the Radio Press papers, and if you read the back issues you are bound to find one which will suit you.

Valve Receivers

It may be, of course, that you are situated in a district where a crystal set will not be sufficiently sensitive to bring in even the nearest station. A valve set will then be a necessity. A properly-made and carefully adjusted single valve set will always bring in at least one station, and very frequently several—indeed, in favourable conditions and with skilled handling, all the main broadcasting stations in this country may be heard. Additional strength, to operate a loud-speaker, can be obtained from a set containing one or two note-magnifying valves.

habit of building and re-building their receivers from time to time as new designs come out and new improvements are introduced. Fortunately, practically all of the component parts of a set built to one design can be used on further designs, the chief changes being in wiring and panel layout. Note, too, that there are certain expenses in connection with valve sets which only occur once. For example, whatever set you build the same telephones will do and the same loud-speaker. If your accumulator is of reasonable size for, say, a two-valve set, you will have no difficulty in working a four-valve set from the same accumulator, although, of course, if the valves are of the bright-emitter type, or of fairly high

consumption, the charge in the accumulator will last for a much shorter period. A high-tension battery suitable for a single valve set will be equally suitable for anything up to a three-valve receiver, while if you build a four or five-valve set, the single receiver high-tension battery can be used in conjunction with others, and thus is not wasted. Similarly, the valve you use in a single set will be sure to find a place in the multi-valver, and as the same aerial and earth are used, the same telephones or loud-speaker, the same valves (with perhaps the addition of one or two more), and as probably nine-tenths of the components of your first set will find a place in the new design,

it is not to be wondered at that embarking upon making of a new receiver is not the expensive business which it might at first appear to be. In fact, it frequently happens that quite a modern receiver can be made out of an old set with no more expense than the cost of a new ebonite panel.

Of course, it is hardly necessary to point out that until you are thoroughly experienced and really competent to design your own receiver, the only safe way is to pick a reliable design and make it as closely as possible to the author's instructions. All the sets described in Radio Press publications (MODERN WIRELESS, *Wireless Weekly*, the *Wireless Constructor*,

Radio Press books, Envelopes and Panel Cards) are designed by experts, and are tried and tested. Every one of them was built and tested out in practical working conditions before any description appeared.

Finally, and even at the risk of boring you, I must repeat the advice which has been so frequently given in these pages—do not try to economise by buying cheap components of unknown manufacture. In no other business is it so easy to make shoddy and worthless apparatus look presentable as in the wireless trade. Remember, too, that British components are unsurpassed in quality by any of foreign origin.

Some Readers' Results with Radio Press Sets

The Seven-Valve T.A.T.

SIR,—I have much pleasure in sending you a photograph of the seven valve T.A.T. (described by Mr. John Scott-Taggart in the January MODERN WIRELESS) as promised.

I am well satisfied with the circuit, and using four valves I get great volume. When I use more than that the set is more selective; but, like your correspondent who constructed the eight-valve set, I feel there is room for an improvement in selectivity. The special American transmission, two Sundays ago, came through very well. If you can make any use of photo I shall be very happy.

Meanwhile, I remain an interested experimenter.

Wishing your circuits every success.—Yours truly, H. A. CASTLE.
High Wycombe.

The Single-Valve Receiver for KDKA.

SIR—I constructed the Single-Valve Receiver for KDKA, described by Mr. Stanley G. Rattee in the MODERN WIRELESS for March, during the week-end, and on Tuesday evening was able to receive KDKA from 11.15—12.12, at good phone strength and without the usual firework display which we get through the B.B.C.

I heard the following items announced and played: "The Lotus Flower," "Springtime Serenade," and finally "Musical Melange," by special request. These

items were relayed from the Pittsburgh Athletic Association dining-room and played by Gregorio Calgo's Orchestra. The announcer then said, "That concludes the dinner hour programme from etc.

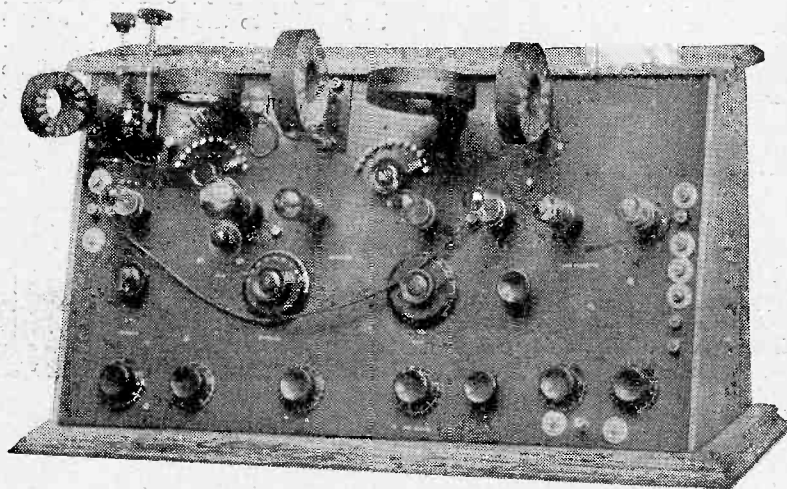

Mr. H. A. Castle's Seven-Valve T.A.T. Receiver.

etc.; please stand by until 7.15." It was then 12.12 G.M.T.

I omitted the .05μF condenser and used a .0003 variable condenser across secondary coil. For simplicity and results this little "Transatlantic One" will take some beating. Thanking you for a remarkable little set.—Yours truly,

CHAS. N. MANN.
Birmingham.

The stations were WBZ, KDKA and WGY.

With outside aerial I have received KDKA, WBZ and WGY on the loud-speaker, which could be heard in any room of the house. I think this set is wonderful for long-distance work.

—Yours truly,

CHAS. A. BAXTER.
Waterbeach, Cambs.

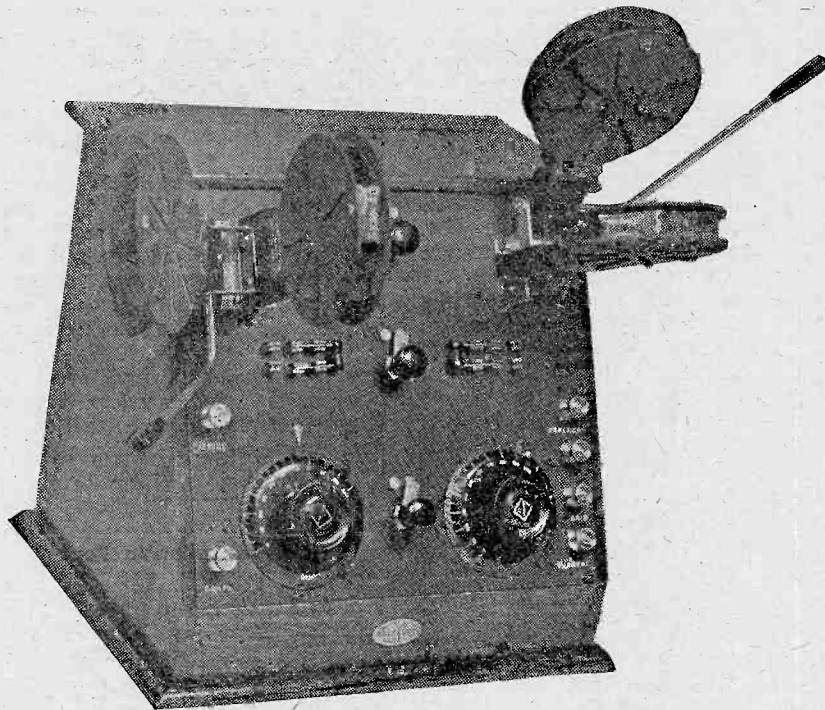

The completed tuner, showing the split-secondary circuit (Fig. 7) in use.

A Split-Secondary Tuner for the Experimenter

By JOHN W. BARBER.

An instrument which is designed for the experimenter who is constantly changing his circuits.

TO the man who is engaged in trying out many different forms of circuits, whether as complete receivers or as board experiments, some standard form of tuning arrangement is a necessity. By this means experiments are considerably facilitated, and if the tuner employed is capable of modification, by means of switches, nothing need be sacrificed for the sake of convenience.

Conditions Necessary

The majority of receivers employed at the present time embody a conventional tuning system, whether directly or loosely coupled, and it would appear a waste of valuable time to rebuild this part of the set for each new circuit tried. Given, then, a well-designed tuner, experiments are greatly facilitated, for all that is necessary is to join up the necessary high-frequency amplifiers, detector, low-frequency valves, and so on.

The conditions such a tuner would have to comply with are quite simple; in most cases direct or loose coupling alone would suffice, with provisions for series or parallel connection of the aerial tuning condenser, for earthing the lower end of the secondary circuit, and for direct or reversed reaction. These provisions will, in general, suffice, but here we come up against

a point which needs some modification, on the score of ease of operation. In a tuner such as that outlined above, it becomes obvious that the reaction coil may either be coupled to the aerial coil or the secondary or closed circuit inductance. In the latter case, it will be seen that, once the reaction coil has

been coupled to the secondary coil in such a manner as to give the best results, any variation in coupling between the aerial and secondary coils will immediately render a resetting of the reaction coupling necessary. If the reaction coil is so adjusted that the set is just off the point of self-oscillation, the effect of loosening the coupling between the aerial and secondary, coils will result in an immediate tendency, on the part of the set, to "flop" over into oscillation. Although these conditions may, by skilled handling, be avoided (by, for example, slackening coupling between reaction and secondary,

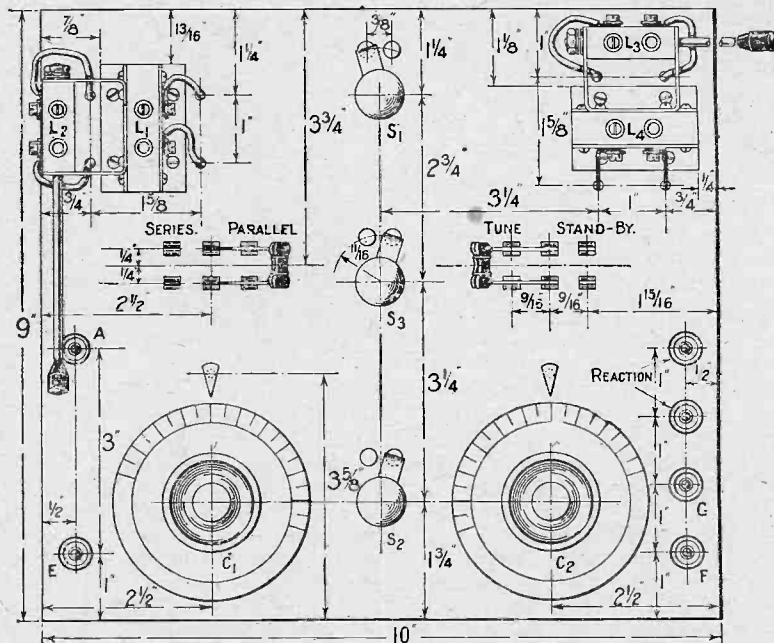
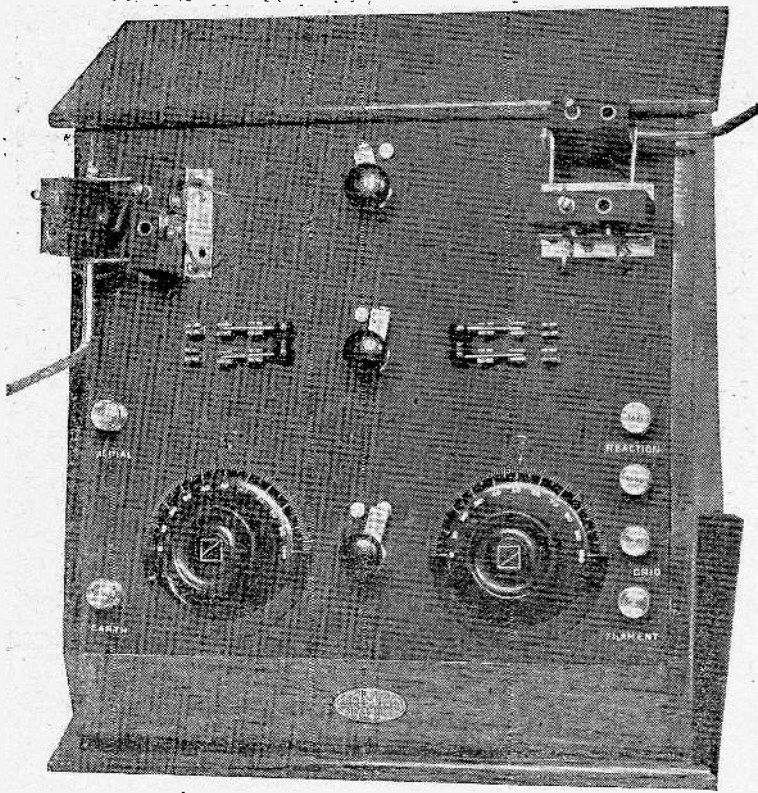

Fig. 1.—The dimensions given above will enable the experimenter to duplicate the instrument. Blue Print No. 105a is available.

With most receivers the tuner is incorporated in the set itself, and it is necessary to reconstruct it when a change in circuits is desired. The tuner described in this article can, however, be attached to any receiver and enables a variety of circuits to be used by a simple arrangement of switches.



A full-face view of the tuner with the coils removed.

and aerial and secondary, coils simultaneously) they constitute an obstacle in the path of speedy work.

Split-Secondary

The method of overcoming this difficulty is by employing a circuit known as the "split-secondary," in which the secondary coil is, as the name implies, divided into two portions, one of which is coupled to the aerial coil, the other forming the inductance to which the reaction coil is coupled. In this way the settings of aerial and reaction coils are independent of one another, while a marked increase in selectivity is obtainable.

Several points in the design of such a tuner face one when considering the construction. Firstly, the change-over from one circuit to another must be simple, no complicated evolutions of changing wires and so on being permitted.

Coupling between coils must be easily varied, some form of long operating handle being preferable. The coupling between the coils must be capable of being reduced to the fullest extent, in order that the full benefits of loose-coupling may be obtained.

Again, important leads must be kept short, those in the aerial and grid circuits demanding most careful attention. Leads on the earth side may, without detriment to the efficiency of the tuner, be left

longer, especially if a greater spacing be thereby obtained. It is also essential that insulation should be of a high standard of quality, indicating careful choice of the ebonite panel. It is also desirable that the tuning condensers be in such a position that they may be adjusted without capacity effects being produced, due to the proximity of the operator's hands.

The instrument to be described was designed to fulfil these requirements, and has been in use at the writer's station for some six months, having given satisfactory service during that period.

Constructional Details

For the benefit of those desiring to construct a standard instrument along the lines of that described, a list of the necessary components is given, together with makers' names, which latter are, however, only intended to serve as a guide, there being no obligation to adhere strictly to the specification.

Firstly, we shall require an ebonite panel of good quality, 10 in. by 9 in. by 1/4 in. being a suitable size. Great care should be taken over the ebonite, to ensure freedom from surface leakage, and thus the best only should be used. It is highly desirable to take great

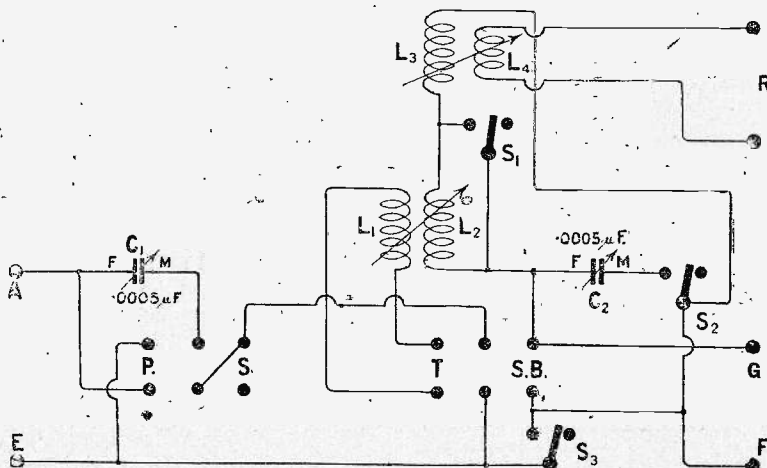

Fig. 2.—The circuit diagram, indicating the switching arrangements.

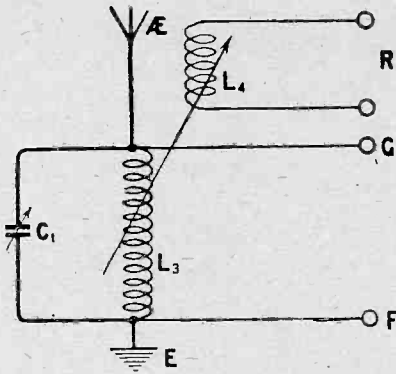

Fig. 3.—The simplest circuit.

care of the minute currents flowing in this part of the receiver, any leakage here being detrimental to the operation of the remainder of the set. Some suitable form of cabinet will be necessary, that used being of the sloping front type made by the Carrington Manufacturing Co.

Components

- 2 Two-way coil holders (Magnum).
- 2 Square Law condensers, .0005 μ F (Bowyer-Lowe).
- 2 Double - pole double - throw switches.

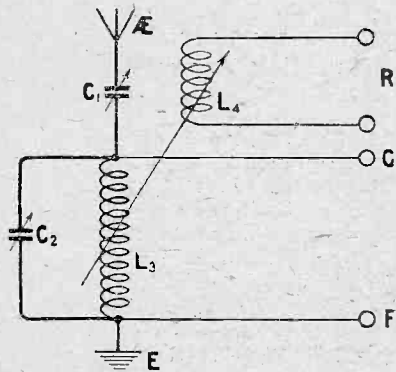

Fig. 6.—Selectivity is improved by the series condenser.

- 3 Switch arms with studs (Bowyer-Lowe).
- 2 "Decko" dial indicators.
- 6 terminals.
- Set of Radio Press panel transfers.
- Square wire for wiring up and some flexible leads.

Layout of the Panel

The panel layout is very simple, a dimensioned drawing being given to assist in the construction. If desired, change-over switches of the "Utility" or similar design may be used, in which case holes will be drilled to suit the needs of the particular component employed. Drilling templates are supplied with the variable condensers, so that nothing further

need be said regarding this section of the work. Wiring is carried out with square-section tinned copper wire, and should be carefully soldered at the necessary places. The wiring diagram given makes all connections perfectly clear, and when used in conjunction with the back-of-panel photograph, no difficulty should be experienced. When completed, the tuner may be placed in the cabinet and secured by screws if necessary, when the instrument will be ready for use.

Switching

The circuit diagram of the tuner itself is given in Fig. 2, which

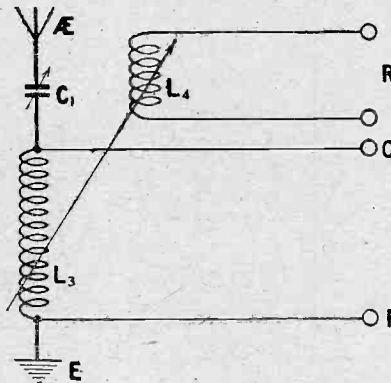

Fig. 5.—A series tuned circuit.

clearly shows the operation of the various switches. The left-hand change-over switch on the front of the panel serves to place the aerial tuning condenser C_1 in series or parallel with the aerial coil. The other change-over switch effects the change from direct to loose coupling, and is, in effect, a "tune-stand-by" switch. On the "tune" side, *i.e.*, employing loose coupling, L_1 is the aerial coil, L_2 the part of the secondary coupled to it, while L_3 is the other part of the secondary coupled to the reaction coil L_4 . The single-pole switch S_3 enables the lower end of the secondary circuit to be earthed.

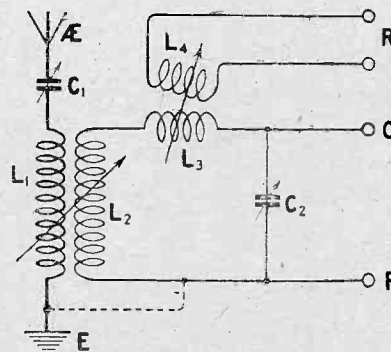

Fig. 8.—Similar to Fig. 7, but with C_1 in series.

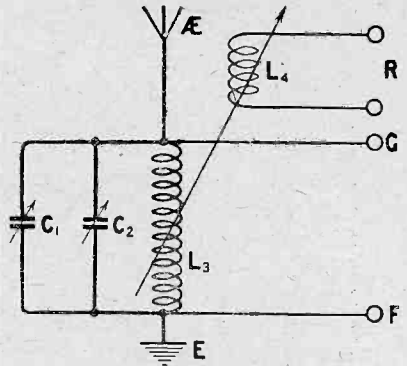

Fig. 4.—Useful for long waves.

"Stand-by"

On the "stand-by" side, L_1 is cut out of circuit, the erstwhile secondary coils now becoming the aerial coils. Switch S_1 short-circuits the part L_2 of the "secondary," leaving L_3 alone in the aerial circuit now, with L_4 coupled to it for reaction effects. In this case, switch S_2 will throw the variable condenser C_2 out of circuit, as the coil L_3 is already in series or parallel, as the case may be, with the condenser C_1 . This particular form of switching is rendered necessary in order that reaction may be used on a direct-coupled circuit, the only disadvantage, a small one, being that it is necessary, when changing over from tune to stand-by, or *vice versa*, to change the coil L_3 .

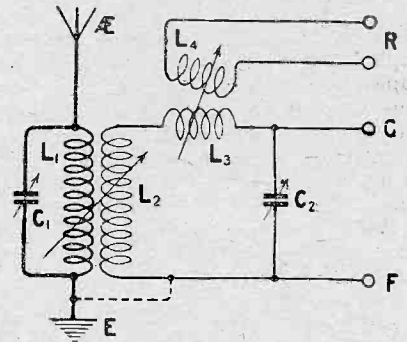

Fig. 7.—Split-secondary circuit with parallel condenser.

A Simple Circuit

Fig. 3 shows the simplest circuit possible, being a direct-coupled circuit with parallel condenser, and reaction. The necessary combination of switches is: Series-parallel switch to the right, other switch to the right. S_1 "on," *i.e.*, shorting L_2 ; S_2 "off"; S_3 may be ignored for obvious reasons.

On longer waves a variable condenser, somewhat larger than that provided in the aerial circuit, may be desirable, in which case switch S_2 is moved to the "on"

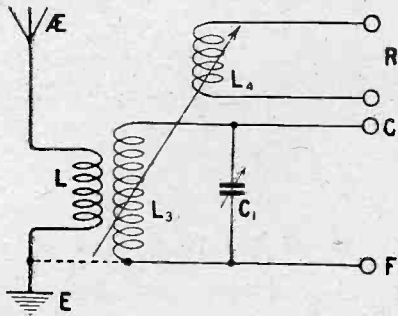

Fig. 9.—A useful aperiodic circuit.

position, thus placing C_2 in parallel with the coil L_3 . We now have the two $.0005 \mu F$ condensers in parallel with this coil, giving a maximum capacity of $.001 \mu F$. This is shown in Fig. 4.

Series Tuning

Still using direct coupling, the aerial condenser may be placed in series with L_3 by simply changing over the "S.P." switch to the left, S_2 being off, and the other switches as above. This circuit is suitable for short-wave reception, and is shown in Fig. 5.

By simply placing the switch S_2 in the "on" position, we now obtain the circuit shown in Fig. 6, which may be considered as a circuit employing constant aerial tuning, if the series condenser is set at a low value.

Coupled Circuits

Coming now to the loosely-coupled circuits, Fig. 7 shows the simple split-secondary circuit, C_1 being in parallel with L_1 , the aerial coil, coupled to which is L_2 , while L_3 , now in the secondary circuit, is coupled to L_4 . To obtain this circuit, the S.P. switch is placed to the right, the tune-stand-by switch being to the left. S_1 is off, S_2 being on. The lower end of the secondary winding may be earthed by placing S_3 in the on position,

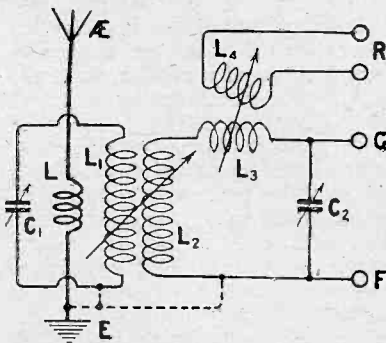

Fig. 10.—An ultra-selective circuit which may be used on this instrument.

this connection being shown dotted in the diagram.

By changing over the S.P. switch to the series side, the circuit shown in Fig. 8 results. This may be tried, and in some cases will be found satisfactory, but in general the parallel connection will be the better.

Aperiodic Circuits

A simple aperiodic circuit is shown in Fig. 9, and may be obtained by the use of a suitable coil, which may be either home-made or of the Igranic Unitune type or similar variety, in combination with switching arrangements, as follows: S.P. switch in the parallel position, "T.S.B." switch on the stand-by side; S_1 on; S_2 off. The special coil is

placed in the other sockets, as described later. In Fig. 10 L represents the small winding on the aerial coil L_1 . The ends of the coil L are joined to aerial and earth respectively, while the earth is also joined to the E terminal of the tuner, terminal A being left free. We thus have the aerial aperiodically coupled to a tuned circuit $L_1 C_1$, which, in turn, is coupled to the tuned circuit $L_2 L_3 C_2$, reaction being introduced by coupling L_3 to L_4 . This circuit should certainly be tried by all who desire extreme selectivity, as it is truly remarkable in this respect.

Coils Needed

Some guidance as to the coils necessary for the split-secondary

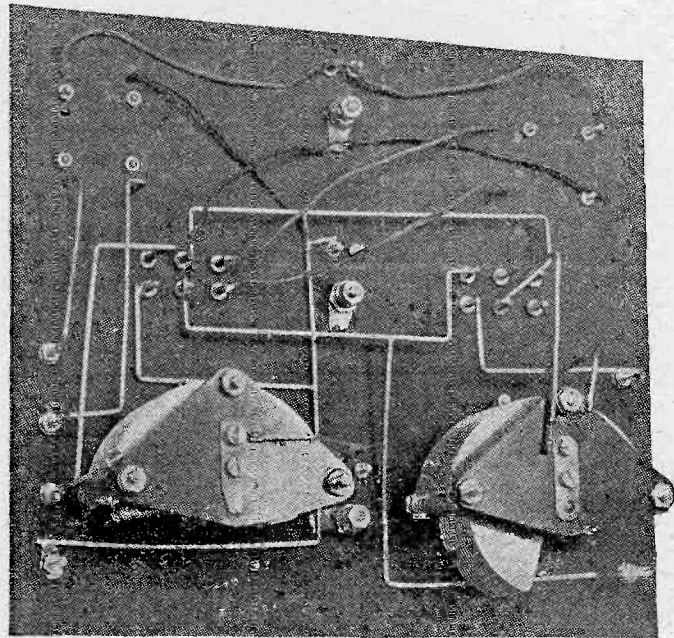

A photograph of the back of the panel, showing all connections clearly.

plugged into socket L_4 , reaction being obtained as before. Aerial and earth leads are joined to appropriate terminals on, or leads from, the special coil. If desired to earth the now secondary coil L_3 , place S_3 in the on position and take a wire from terminal E of the tuner to earth.

A Specially Selective Circuit

By using an aperiodic coil such as mentioned above, a very selective circuit may be obtained, and is shown in Fig. 10. Switching arrangements are parallel, tune, S_1 off, S_2 on, S_3 on. The special aperiodic coil is plugged into the aerial socket L_1 , suitable coils being

circuits will be needed, and a few details are given here.

For the broadcast band of wavelengths up to 500 metres the aerial coil may be a Gambrell A or B, coupled to a Gambrell B or C. The other half of the secondary may be a Gambrell "a" coil, while a reaction coil of suitable size may be chosen. In the numbered series of coils, L_1 may be a No. 35 or 50, L_2 a No. 50, L_3 a No. 25, a suitable coil of suitable size being again chosen.

In Burndep't's range of coils, S_2, S_3, S_1 and S_4 may be used in the positions L_1, L_2, L_3, L_4 respectively. For reception of the long wave station, and as a rough guide for

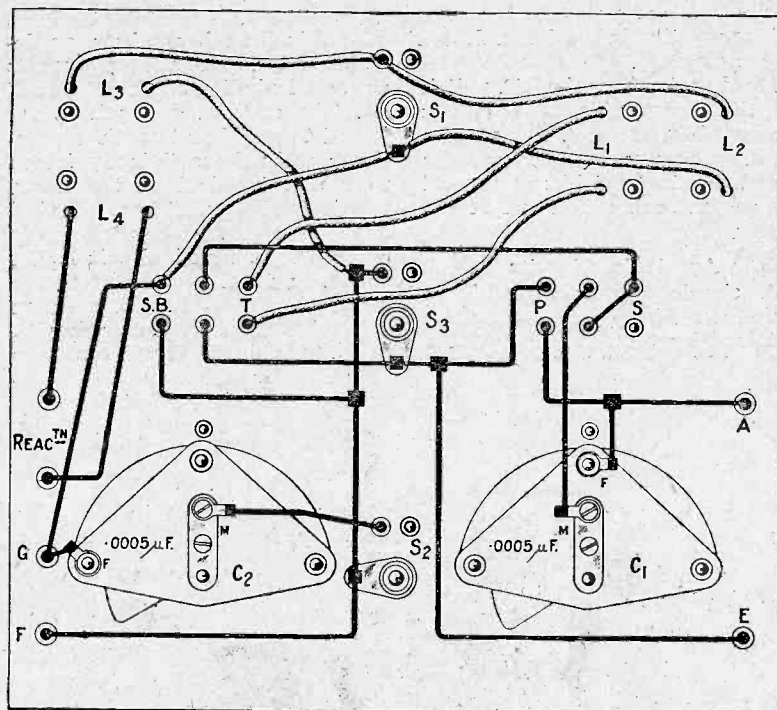

Fig. 11.—If this wiring diagram be used in conjunction with the back-of-panel photograph given on the previous page, no difficulty will be encountered in wiring up the instrument. Full size Blue Print No. 105b may be obtained.

longer wave reception in general, L_1 may be a No. 150, L_2 a No. 200, L_3 a No. 50, while L_4 is chosen to suit.

When using the simpler forms of circuit with the change-over switch on the "stand-by" side, the ordinary coils for aerial and reaction may be used, and in general for broadcast reception a Number 35 or 50 coil may be used as aerial coil (L_3 in this case) and a suitable reaction coil is then chosen to give smooth control of reaction. This should be of such a size that the set will just oscillate when the coils are quite close together. This latter remark also applies to the other circuits which are available upon this instrument.

Interference

No difficulty is experienced in eliminating interference from the local station once the "hang" of the circuit is obtained, it actually being possible to receive those B.R.C. stations whose wavelengths are closest to that of London while the latter station is working.

This principle has been very little used in this country, and quite deserves more attention, and I feel sure that once any prejudice is overcome, and a tuner built upon these lines, the advantages of "split-secondary" tuning will be realised and fully appreciated.

Elimination of High-Frequency Losses

With the extremely rapid growth of popularity of the short waves has come the necessity for the further reduction of high-frequency losses in apparatus such as variable condensers, valves and switches. Although the properties of these ultra short waves are as yet little known, much experimental work is being carried out in an endeavour to determine exactly the losses that are occasioned by stray capacities and the use of different dielectrics in coils and condensers.

The *Wireless Weekly*, in its usual manner of getting at the root of things, publishes the views of some well-known investigators upon this matter, and in the issue dated February 18th, Mr. Philip R. Coursey, B.Sc., F.Inst.P., A.M.I.E.E., contributed a particularly interesting and illuminating article on "Low-Loss Condensers," in which he discussed the use of small insulating bushes and metal ended variable condensers, and also gave some very

practical information about the electric stress in the dielectric for rods of various substances, separated by various thicknesses of dielectric. In the issue dated February 25th, an American contributor, Mr. Sylvan Harris, expressed some further opinions which in view of Mr. Coursey's article makes very interesting reading when compared with the previous issue.

Another article of outstanding interest that has appeared recently in *Wireless Weekly* (March 11th) is one by Mr. John Scott-Taggart, F.Inst.P., A.M.I.E.E., entitled "Grid-Choke Rectification." In this Mr. Scott-Taggart describes a method of rectification whereby the usual gridleak is replaced by a choke, and his remarks open a new field of experiment for those who have not previously considered the possibility of such methods of detection.

For those who are interested in Reflex Circuits, there is an article of interest in *Wireless Weekly*, dated February 25th, written by Mr. John Scott-Taggart, in which he discourses upon the advantages and disadvantages of reflex working, besides making a prophecy as to

the ultimate end to which dual receivers will come.

By far one of the most commendable new features incorporated in *Wireless Weekly* for some time is *The Foreign Radio Times*, which, besides giving the usual list of Continental and American stations with their call signs and wavelengths, states the precise times and nature of the transmissions and also the items included in the programmes. This should render the identification of foreign stations comparatively easy after the trouble experienced in distinguishing between stations whose wavelengths are very close. It even makes the identification of a station possible by a person not knowing a word of the language of the country in which a particular item is played, by simply knowing that item. This feature first appeared in the issue dated March 4th, and is being continued weekly.

In conclusion, those requiring extremely flexible tuning arrangements are recommended to read the article on "Split Secondary Tuning," by Mr. Stanley G. Rattee, M.I.R.E., appearing in the issue dated February 18th.

GECOPHONE

WIRELESS COMPONENTS

-the little things that count!

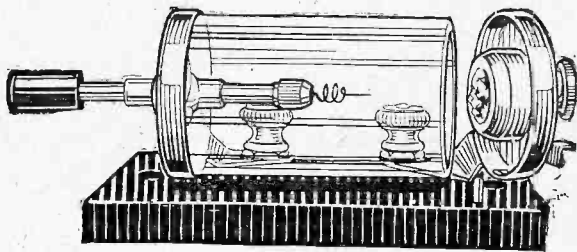

GECOPHONE PATENT "UNIT" CRYSTAL DETECTOR.
 Instant accessibility by lifting small lever when detector swings open. Universal ball joint self-contained in spring cage. Constant contact. Crystal breech fed from outside of tube.
 Cat. No. **B.C. 32.** For Panel mounting. Price 2/- each.
 " " **B.C. 34.** Mounted on base. " 2/6 "
 Without Crystal.

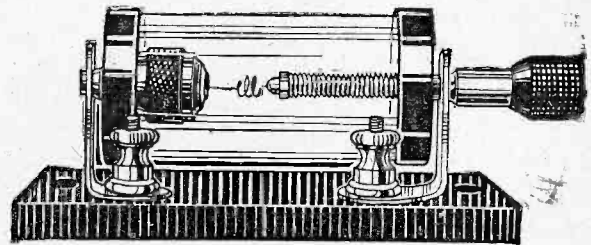

GECOPHONE MICROMETER CRYSTAL DETECTOR
 Screw-on crystal cup. Detector arm has free sliding movement for quick contact. Micrometer movement for final adjustment. Operated from one knob.
 Cat. No. **B.C. 36.** For Panel mounting. Price 4/- each.
 " " **B.C. 38.** Mounted on base. " 4/6 "
 Complete with "Gecoslite" Crystal.

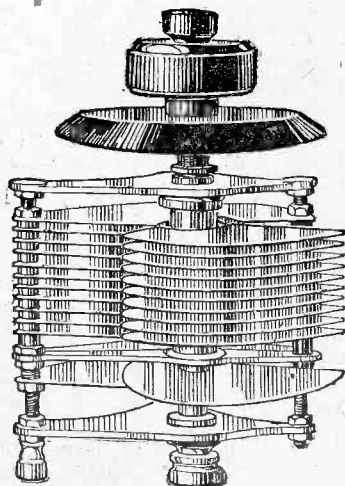

GECOPHONE SQUARE LAW VARIABLE CONDENSER.

Even tuning over entire scale. Minimum capacity unusually low. Low dielectric losses.

Without Vernier.		With Vernier.	
B.C. 200	.0002 mfd. 9/6	B.C. 201	.0002 mfd. 14/6
B.C. 202	.00025 " 10/3	B.C. 203	.00025 " 15/3
B.C. 204	.0003 " 10/3	B.C. 205	.0003 " 15/3
B.C. 206	.0005 " 10/6	B.C. 207	.0005 " 15/6
B.C. 208	.00075 " 12/-	B.C. 209	.00075 " 17/-
B.C. 210	.001 " 12/6	B.C. 211	.001 " 17/6



Open for taking stripped end of lead.

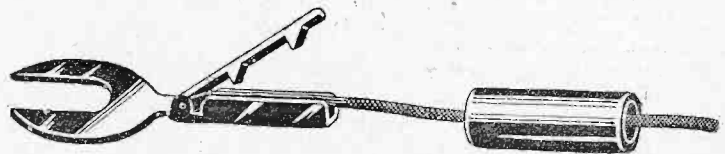

Closed for use.

THE GECOPHONE GRIP TERMINAL.

The easiest way of making all electrical connections. An entirely new and novel wireless accessory which will find favour with all wireless users. Saves time and worry. No soldering. No screws. Ease and speed of assembly. Entirely obviates loose joints. Attractively finished in nickel plate. Red or black insulating sleeves.

Cat. No. **B.C. X 351** (Spade Type) } Price 6d. each.
 Cat. No. **B.C. X 355** (Pin Type)

SOLD BY ALL GECOPHONE SERVICE DEPOTS, ELECTRICAL & WIRELESS DEALERS, STORES, ETC.

(Manufacturers and Wholesale only)

THE GENERAL ELECTRIC CO., LTD., Head Office: Magnet House, Kingsway, London, W.C.2.



Brandes Superior
Matched Tone
Headphones

PRICE NOW

20/-

British - Manufacture
(B. B. C. Stamped)

All Brandes products carry our official money-back guarantee, enabling you to return them within 10 days if dissatisfied. This really means a free trial.

Brandes Superior *Matched Tone* Headphones are admirably versatile. It's hard to imagine them fitting snugly to the tenderest curly head and yet fulfilling their duty on the head of the expert who sits down to long hours of serious experiment. So comfortable and with a rugged strength of construction to protect their delicate adjustment, they are excellent for family use. Primarily designed for long-range telephony from expert technical knowledge, their *Matched Tone* feature brings in the most distant signals with purity and strength. The experimenter finds that they bring the best results in trans-Atlantic and trans-Continental reception. One gentleman writes from Walton-on-Thames: "I received Australia on Brandes, and consider they are the most sensitive 'phones I have used. I am much pleased with their general performance." Ask your Dealer for Brandes.

The *Table-Talker* is another Brandes quality product at moderate price. Its full round tones are wonderfully clear and pleasing. The horn is matched to the unit so that the air resistance produced will exactly balance the mechanical power of the diaphragm. This means beautiful sound balance. Gracefully simple of line, it is finished a shade of neutral brown and is twenty-one inches high.

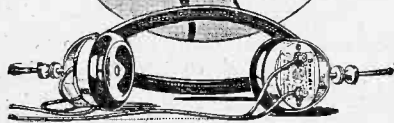

..... every one of these advertisements will show an added advantage in the construction of Brandes Headphones.

Look at the illustration above. See how snugly the 'phones fit the head. A gentle pressure on the crown, a firm clasp to the ears, and the rest of the head-band is held well away from the hair. This means long-wearing comfort and the shutting out of extraneous sounds. Strength and firm beauty of lines typifies their finished construction.



Table-Talker
42/-

Brandes

The Name to know in Radio

Brandes Limited, 296, Regent Street, W.1.

WORKS:
Slough, Bucks

20/-



Superior "Matched Tone" Headphones

TRADE MARK

Regular Programmes from Continental Broadcasting Stations

Telephony except when otherwise stated.

Edited by CAPTAIN L. F. PLÜGGE, B.Sc., F.R.Ae.S., F.R.Met.S. Strictly Copyright.

All Hours of Transmissions reduced to British Summer Time.

Until British Summer Time comes into force, note that one hour should be subtracted from times given.

Ref. No.	B. S. T.	Name of Station.	Call Sign and Wave-length.	Situation	Nature of Transmission.	Closing Time or Approx. Duration.	Approx. Power used.
WEEK DAYS.							
	a.m.						
1	7.25	Hamburg	— 395 m.	Germany	Time Signal in C.E.T. and Exc.	5 mins.	1.5 Kw.
2	7.40	Eiffel Tower	FL 2600 m.	Paris	Weather Forecast	5 mins.	5 Kw.
5	7.55	Persbureau Vaz Dias	PCFF 2125 m.	Amsterdam	Stocks, Shares and News	10 mins.	2 Kw.
4	8.05	Lausanne	HB2 850 m.	Switzerland	Weather Report	5 mins.	300 Watts
211	9.00	Radio-Wien	— 530 m.	Austria	Market prices	10 mins.	1 Kw.
9	9.55	Persbureau Vaz Dias	PCFF 2125 m.	Amsterdam	Stocks, Shares and News	10 mins.	2 Kw.
8	10.23	Eiffel Tower	FL 2650 m.	Paris	Time Signal in G.M.T. (Spark)	3 mins.	60 Kw.
11	10.30	Lyons	YN 550 m.	Lyons	Gramophone Records	30 mins.	300 Watts.
10	11.00	Eiffel Tower	FL 2650 m.	Paris	Time Signal in Greenwich Sidereal Time (Spark)	5 mins.	60 Kw.
156	11.00	Radio Wien	— 530 m.	Austria	Concert	12.50 p.m.	1.5 Kw.
180	11.15	Breslau	— 478 m.	Silesia	Weather Report—Exchange	10 mins.	1.5 Kw.
12	11.30	Kbel	— 555 m.	Prague	Exchange quotations	10 mins.	1 Kw.
13	11.44	Eiffel Tower	FL 2650 m.	Paris	Time Signal in G.M.T. (Spark)	3 mins.	60 Kw.
14	11.55	Eiffel Tower	FL 2600 m.	Paris	Fish Market Quotations—Cotton Exchange.	10 mins.	5 Kw.
15	11.55	Frankfurt	— 470 m.	Frankfurt	Time Signals in C.E.T. (spoken) followed by News	5 mins.	1 Kw.
	noon						
182	12.00	Leipzig	— 454 m.	Germany	Concert	12.50 p.m.	700 Watts.
184	12.00	Zurich	— 515 m.	Switzerland	Weather Report	5 mins.	500 Watts.
24	12.00	Persbureau Vaz Dias.	PCFF 2125 m.	Amsterdam	Stocks and Shares	8 mins.	2 Kw.
	p.m.						
17	12.10	Persbureau Vaz Dias.	PCFF 2125 m.	Amsterdam	Stocks and Shares	20 mins.	2 Kw.
18	12.14	Eiffel Tower	FL 2600 m.	Paris	Time Signal in Greenwich Time (spoken), followed by Weather Forecast.	5 mins.	5 Kw.
20	12.15	Voxhaus	— 430 m.	Berlin	Exchange Opening Prices	5 mins.	700 Watts.
30	12.30	Stockholm	— 430 m.	Sweden	Weather Forecast, followed by Exchange and Time Signal from Nauen.	1 p.m.	750 Watts.
32	12.30	Radio-Paris	SFR 1780 m.	Clichy	Concert followed by News	2 p.m.	8 K.w.
31	12.45	Persbureau Vaz Dias.	PCFF 2125m.	Amsterdam	Stocks and Shares	10 mins.	2 Kw.
23	12.57	Nauen	POZ 3000 m.	Berlin	Time Signal in G.M.T. (Spark) This signal is relayed by Zurich and all German Stations except Frankfurt, Munich, and Stuttgart.	8 mins.	50 Kw.
157	1.00	Zurich	— 515 m.	Switzerland	Weather Forecast, Shares, News	5 mins.	500 Watts.
33	1.00	Haeren	BAV 1100 m.	Brussels	Weather Forecast in French and English.	8 mins.	150 Watts
26	1.15	Geneva	HB1 1100 m.	Switzerland	Lecture	1.45 p.m.	300 Watts.
25	1.30	Kbel	— 555 m.	Prague	Exchange Quotations	10 mins.	1 Kw.
27	1.30	Lausanne	HB2 850 m.	Switzerland	Weather Reports, Time Signal in C.E.T. and News	15 mins.	300 Watts.
34	2.00	Munich	— 485 m.	Bavaria	News and Weather Report	10 mins.	1 Kw.
35	2.00	Komarow	— 1800 m.	Czecho-Slovakia.	Stock Exchange and Late News	10 mins.	1 Kw.
37	2.15	Voxhaus	— 430 m.	Berlin	Stock Exchange News	5 mins.	700 Watts
39	2.45	Eiffel Tower	FL 2600 m.	Paris	Exchange Opening Prices (Sat. excepted).	8 mins.	5 Kw.

Ref. No.	B. S. T.	Name of Station.	Call Sign and Wave-length.	Situation.	Nature of Transmission.	Closing Time or Approx. Duration.	Approx. Power used.
----------	----------	------------------	----------------------------	------------	-------------------------	-----------------------------------	---------------------

WEEK DAYS (Contd.)

181	p.m. 3.00	Breslau ..	— 418 m.	Silesia ..	News & Exchange Quotations	10 mins.	1.5 Kw.
40	3.30	Munster ..	— 410 m.	Westphalia	Stocks, Shares and News	10 mins.	1.5 Kw.
47	3.35	Eiffel Tower ..	FL 2600 m.	Paris ..	Exchange Quotations (Sat. excepted).	5 mins.	5 Kw.
38	3.40	Persbureau Vaz Dias. ..	PCFF 2125m.	Amsterdam	Stocks, Shares and News	10 mins.	2 Kw.
48	3.55	Persbureau Vaz Dias. ..	PCFF 2125 m.	Amsterdam	Stock Exchange and News	10 mins.	2 Kw.
158	4.00	Zurich ..	— 515 m.	Switzerland	Hotel Baur au Lac Concert, Relayed.	6 p.m.	500 Watts.
202	4.00	Munster ..	— 410 m.	Westphalia	Concert	5 p.m.	1.5 Kw.
159	4.00	Radio-Wien ..	— 530 m.	Vienna ..	News followed by Concert	6 p.m.	1.5 Kw.
42	4.30	Frankfurt ..	— 470 m.	Germany ..	Light Orchestra	6 p.m.	1 Kw.
43	4.30	Konigsberg ..	— 463 m.	East Prussia	Light Orchestra (Wed. & Sat., Children's Hour).	6 p.m.	1 Kw.
44	4.30	Voxhaus ..	505 & 430 m.	Berlin ..	Concert, followed by News	6 p.m.	700 Watts.
46	4.30	Leipzig ..	— 454 m.	Germany ..	Concert	6 p.m.	700 Watts.
51	4.30	Radio-Paris ..	SFR 1780 m.	Clichy ..	Concert preceded and followed by News.	5.45 p.m.	8 Kw.
52	4.30	Eiffel Tower ..	FL 2600 m.	Paris ..	Exchange Closing Prices (except Saturday).	8 mins.	5 Kw.
160	5.00	Breslau ..	— 418 m.	Silesia ..	Light Orchestra	6 p.m.	1.5 Kw.
226	5.00	Stuttgart ..	— 443 m.	Wurtemberg	Concert	6.30 p.m.	1 Kw.
54	5.00	Radio-Belg. ..	SBR 265 m.	Brussels ..	Concert followed by News.	6 p.m.	2.5 Kw
186	6.00	Frankfurt ..	— 470 m.	Germany ..	Lectures	7.30 p.m.	1 Kw.
187	6.00	Hamburg ..	— 395 m.	Germany ..	Music or Lecture	7.00 p.m.	1.5 Kw.
162	6.00	Eiffel Tower ..	FL 2600 m.	Paris ..	Concert followed by News Bulletin	6.55 p.m.	5 Kw.
177	6.00	Radio-Barcelona ..	EAJI 325 m.	Barcelona	Concert	7.00 p.m.	650 Watts.
161	6.30	Munich ..	— 485 m.	Bavaria ..	Light Orchestra or Lecture	7.30 p.m.	1 Kw.
230	7.00	Komarow ..	— 1800 m.	Czecho-Slovakia	Lecture or Concert	8 p.m.	1 Kw.
57	7.15	Kbel ..	— 555 m.	Prague ..	Lecture	20 min.	1 Kw.
63	7.30	Stuttgart ..	— 443 m.	Wurtemberg	Lecture followed by Evening Programme	11 p.m.	1 Kw.
164	7.30	Radiofonica Italiana. ..	— 425 m.	Rome ..	Concert followed by News (Interval between 8.20 and 8.30).	9.30 p.m.	4 Kw.
58	8.00	Eiffel Tower ..	FL 2600 m.	Paris ..	General Weather Forecast	8 mins.	5 Kw.
188	8.00	Frankfurt ..	— 470 m.	Germany ..	Lecture	8.30 p.m.	1 Kw.
61	8.00	Konigsberg ..	— 463 m.	East Prussia	Concert and News	10 p.m.	1.5 Kw.
62	8.00	Hamburg ..	— 395 m.	Germany ..	Concert and Late News and Dance Music	11 p.m.	1.5 Kw.
227	8.00	Kbel ..	— 555 m.	Prague ..	Evening Concert	10 p.m.	1 Kw.
74	8.15	Radio-Belg. ..	SBR 265 m.	Brussels ..	Concert preceded and followed by News.	10.10 p.m.	2.5 Kw.
66	8.15	Lausanne ..	HB2 850 m.	Switzerland	Concert (Monday excepted)	10.30 p.m.	300 Watts.
64	8.15	Zurich ..	— 515 m.	Switzerland	Concert followed by Late News	10 p.m.	500 Watts.
65	8.15	Leipzig ..	— 454 m.	Germany ..	Concert and News (3 days a week till 11.30 p.m.)	10 p.m.	700 Watts.
67	8.30	Frankfurt ..	— 470 m.	Germany ..	Concert and News	11 p.m.	1 Kw.
59	8.30	Munster ..	— 410 m.	Westphalia	Concert followed by News	10.45 p.m.	1.5 Kw.
72	8.30	Voxhaus ..	— 430 m. & 505 m.	Berlin ..	Concert followed by News and Weather Report	10.30 p.m.	0.7 and 1.5 Kw.
73	8.30	Munich ..	— 485 m.	Bavaria ..	Concert and News	11 p.m.	1 Kw.
69	8.30	Breslau ..	— 418 m.	Silesia ..	Concert	10 p.m.	1.5 Kw.
75	8.30	Ecole. Sup. des P. & Tg. ..	FPTT 450 m.	Paris ..	Concert, sometimes preceded by Lecture, usually outside broadcast.	9 p.m.	500 Watts.
60	8.30	Radio-Wien ..	— 530 m.	Vienna ..	Evening Programme	10 p.m.	1.5 Kw.
76	8.30	Radio-Paris ..	SFR 1780 m.	Clichy ..	Detailed News Bulletin	9 p.m.	8 Kw.
77	9.00	Radio-Paris ..	SFR 1780 m.	Clichy ..	Time Signal followed by Concert	9.50 p.m.	8 Kw.
78	9.00	Radio-Iberica ..	RI 392 m.	Madrid ..	Concert and Advertisements.	Midnight	3 Kw.
189	9.00	Radio-Barcelona ..	EAJI 325 m.	Barcelona ..	Concert	11 p.m.	650 Watts.
79	11.00	Eiffel Tower ..	FL 2650 m.	Paris ..	Time Signal in Greenwich Sidereal Time (Spark).	5 mins.	60 Kw.
80	11.10	Eiffel Tower ..	FL 2600 m.	Paris ..	General Weather Forecast	5 mins.	5 Kw.
81	11.44	Eiffel Tower ..	FL 2650 m.	Paris ..	Time Signal in G.M.T. (Spark)	3 mins.	60 Kw.
82	12.57	Nauen ..	POZ 3000 m.	Berlin ..	Time Signal in G.M.T. (Spark)	8 mins.	50 Kw.

LISSENIUM

Don't cramp your tuning

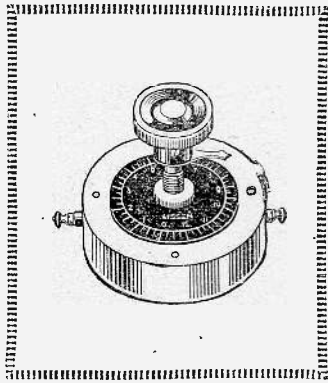

WITH an ordinary condenser you can often get three stations with a degree of scale movement. Think of the painstaking care necessary which short-wave work calls for with such a condenser, and how easy it is to miss those distant stations altogether.

The first time you use the LISSEN MARK 2 MICA VARIABLE CONDENSER you will appreciate its delightful control of tuning. In it you have a condenser which covers every capacity from a negligible minimum up to its conservatively rated maximum of .001. The economy and convenience of this condenser is worth noting therefore.

If you want to try a perfect CONDENSER, try the LISSEN MARK 2 MICA VARIABLE (patents pending).

LISSEN ONE HOLE FIXING, OF COURSE,
Table or panel mounting, without alteration

17/6

LISSENAGON "X" Coils

IN addition to the well-known and standard Lissenagon Coils we have now introduced the Lissenagon "X" Coils. They are similar to standard Lissenagon Coils but have the addition of two tapping points brought out to easily accessible terminals on the coil mount. Used for aperiodic aerial tuning Lissenagon "X" Coils give very great selectivity, whilst reaction control is exceptionally smooth and much finer than is usually obtainable. Used in Neutrodyne Circuits, the high frequency amplification obtained, when using

Lissenagon "X" Coils, is remarkably stable, the use of one or other of the tapping points having the effect of neutralising the grid-plate capacity of the valve.

Lissenagon "X" Coils are very highly efficient when used in the "Neutral Grid" Circuits described by Mr. Cowper.

The No. 60 Lissenagon "X" Coil is now available and covers all broadcast wavelengths whether used for aerial or anode circuit.

Price - - - **6/4**

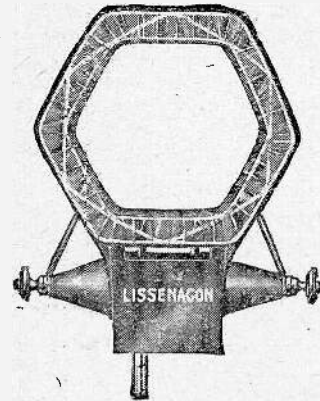

With LISSENAGON COILS and the LISSEN CONDENSER you have the finest tuning combination you can get.

LISSEN LIMITED,

20-24, WOODGER ROAD, GOLDHAWK ROAD,
SHEPHERD'S BUSH ——— LONDON, W.12.

Telephones—Riverside 3380, 3381, 3382, 1072.

Telegrams—Lissenium, London.

The AMPLION RANGE

NO Loud Speaker manufacturers in the world can offer a range comparable with the series of AMPLION models marketed by the House of Graham.

There is an AMPLION for every purpose, and to suit every purse, from the Dragonfly—a real "Baby" Loud Speaker—to the big concert and demonstration models.

Made by the originators and principal manufacturers of loud speaking telephones, the AMPLION has not been hastily devised to meet a sudden demand, but represents the highest development in Loud Speaker construction.

Backed additionally by the famous Service of the House of Graham which guarantees unconditionally every instrument sold, the AMPLION is everywhere and for every purpose the BEST as well as the CHEAPEST.

Obtainable from AMPLION STOCKISTS and Wireless Dealers everywhere.

The World's Standard **AMPLION** Wireless Loud Speaker

For Better Radio
Reproduction

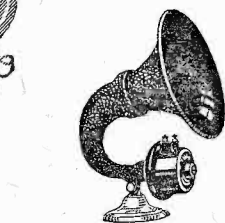

"Dragonfly" Baby Amplifier
A.R. 102
25/-

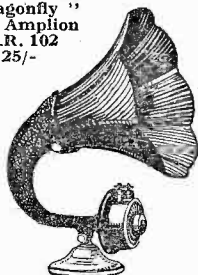

"New" Junior De Luxe A.R. 114
£3 5 0



"Concert" Dragon Model A.R. 23
£8 10 0

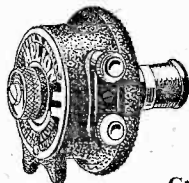

Gramophone Adaptor "Standard" Model A.R. 67
£2 2 0

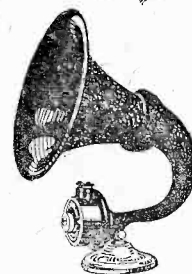

"New" Junior A.R. 111
£2 10 0



"Swan-Neck" Table Model A.R. 15
£6 0 0

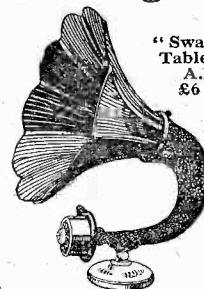

Standard "Dragon" Model A.R. 19
£5 5 0

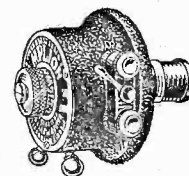

Gramophone Adaptor "Concert" Model A.R. 35 £3 0 0

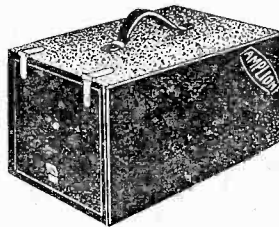

Portable complete with Collapsible Stand for use both in and out of doors
A.R. 61 £6 6 0

ALFRED GRAHAM & CO. (E. A. GRAHAM),
St. Andrew's Works, Crofton Park, London, S.E.4.
Demonstrations gladly given during broadcasting hours at:—
West End Showrooms: 25-6, S. Vile Row, W.1. Suburban Showrooms: 70-82, High St., Clapham, S.W.4.

Ref. No.	B. S. T.	Name of Station.	Call Sign and Wave-length.	Situation.	Nature of Transmission.	Closing Time or Approx. Duration.	Approx. Power used.
SUNDAYS.							
83	a.m. 8.30	Frankfurt	— 470 m.	Germany	Morning Prayer	1 hour	1 Kw.
85	9.00	Leipzig	— 454 m.	Germany	Morning Prayer	1 hour	700 Watts.
165	9.00	Konigsberg	— 463 m.	E. Prussia	Morning Prayer	9.45 a.m.	1.5 Kw.
212	9.00	Voxhaus	— 430 m.	Berlin	Morning Prayer	10 a.m.	700 Watts.
213	9.40	Bloemendaal	— 345 m.	Holland	Divine Service	1 hour	—
86	10.00	Komarow	— 1800 m.	Czecho-Slovakia	Sacred Concert	1 hour	1 Kw.
87	10.23	Eiffel Tower	FL 2650 m.	Paris	Time Signal in G.M.T. (Spark)	3 mins.	60 Kw.
93	10.30	Lyons	YN 550 m.	Lyons	Gramophone Records	11 a.m.	300 Watts.
89	11.00	Eiffel Tower	FL 2650 m.	Paris	Time Signal in Greenwich Sidereal Time (Spark)	5 mins.	60 Kw.
90	11.00	Kbel	— 1160 m.	Prague	Classical Music	1 hour	1 Kw.
92	11.00	Radio-Wien	— 530 m.	Vienna	Concert	12.50 p.m.	1.5 Kw
191	11.15	Hamburg	— 395 m.	Germany	Concert	12.15 p.m.	1.5 Kw.
94	11.30	Stuttgart	— 443 m.	Wurtemberg	Classical Concert	1 hour	1 Kw.
192	11.30	Munich	— 485 m.	Bavaria	Sacred Concert	12.30 p.m.	1 Kw.
96	11.30	Konigswusterhausen.	LP 2900 m.	Berlin	Concert	12.50 p.m.	6 Kw.
95	11.44	Eiffel Tower	FL 2650 m.	Paris	Time Signal in G.M.T. (Spark)	3 mins.	60 Kw.
97	11.55 noon	Eiffel Tower	FL 2600 m.	Paris	Fish Market Quotations, followed by Weather Report.	12 mins.	5 Kw.
214	12.00	Munster	— 410 m.	Westphalia	Morning Prayer	1.30 p.m.	1.5 Kw.
98	12.00 p.m.	Stockholm	— 440 m.	Sweden	Divine Service	1.15 p.m.	500 Watts.
102	12.45	Radio-Paris	SFR 1780 m.	Clichy	Concert followed by News	2.00 p.m.	8 Kw.
101	12.57	Nauen	POZ 3000 m.	Berlin	Time Signal in G.M.T. (Spark)	3 mins.	—
216	3.00	Lyngby	— 2400 m.	Denmark	News	10 min.	500 Watts.
108	4.00	Munich	— 485 m.	Bavaria	Concert	5.00 p.m.	1 Kw.
215	4.00	Munster	— 410 m.	Westphalia	Concert	5.00 p.m.	1.5 Kw.
104	4.00	Breslau	— 418 m.	Silesia	Children's Stories	4.30 p.m.	1.5 Kw.
105	4.00	Stuttgart	— 443 m.	Wurtemberg	Light Orchestra	6.00 p.m.	1 Kw.
107	4.00	Frankfurt	— 470 m.	Germany	Children's Corner	5.00 p.m.	1 Kw.
107	4.00	Zurich	— 515 m.	Switzerland	Local Hotel Concert	6.00 p.m.	500 Watts
106	4.00	Radio-Wien	— 530 m.	Vienna	Afternoon Concert, preceded by News.	6.00 p.m.	1.5 Kw.
168	4.30	Konigsberg	— 463 m.	E. Prussia	Light Orchestra	6.00 p.m.	1.5 Kw.
169	4.30	Voxhaus	430 & 505 m.	Berlin	Light Orchestra	6 p.m.	1 Kw.
170	4.30	Leipzig	— 454 m.	Germany	Light Orchestra	6.00 p.m.	700 Watts.
217	4.40	Bloemendaal	— 345 m.	Holland	Divine Service	5.40 p.m.	—
110	4.45	Radio-Paris	SFR 1780 m.	Clichy	Concert, followed by News	1 hour	8 Kw.
171	5.00	Frankfurt	— 470 m.	Germany	Light Orchestra	6.00 p.m.	1 Kw.
111	5.00	Radio-Belg.	SBR 265 m.	Brussels	Concert	1 hour	2.5 Kw.
180	5.30	Barcelona	EAJI 325 m.	Spain	Concert	8.50 p.m.	650 Watts.
173	6.00	Frankfurt	— 470 m.	Germany	Lecture, followed by Evening Programme.	10.00 p.m.	1 Kw.
112	6.00	Eiffel Tower	FL 2600 m.	Paris	Concert, followed by News	1 hour	5 Kw.
219	6.00	Malmö	SASC 270 m.	Sweden	Concert	8 p.m.	500 Watts.
176	6.45	Copenhagen	— 750 m.	Denmark	Concert, followed by News	7.45 p.m.	2 Kw.
228	7.00	Komarow	— 1800 m.	Czecho-Slovakia	Lecture or Concert	8 p.m.	1 Kw.
175	7.35	Radiofonica Italiana.	— 425 m.	Rome	Concert, followed by Late News.	9.30 p.m.	4 Kw.
126	7.40	Ned. Seintoesl Fabriek.	NSF 1060 m.	Hilversum	Concert	10.10 p.m.	3 Kw.
114	8.00	Radio-Wien	— 530 m.	Vienna	Concert	10.00 p.m.	1 Kw.
118	8.00	Konigsberg	— 463 m.	E. Prussia	Concert	10.00 p.m.	1.5 Kw.
119	8.00	Hamburg	— 395 m.	Germany	Concert, followed by News	10.00 p.m.	1.5 Kw.
120	8.00	Eiffel Tower	FL 2600 m.	Paris	General Weather Forecast	8 mins.	5 Kw.
125	8.00	Stuttgart	— 443 m.	Wurtemberg	Concert. Dance Music from 10 p.m.	Midnight.	1 Kw.
124	8.00	Breslau	— 418 m.	Silesia	Light Orchestra. Dance Music at 10 p.m.	10.30 p.m.	1.5 Kw.
231	8.00	Kbel	— 555 m.	Prague	Evening Concert	10.0 p.m.	1 Kw.
127	8.15	Radio-Belg.	SBR 265 m.	Brussels	Concert, followed by News	10.10 p.m.	2.5 Kw.
121	8.15	Lausanne	HB2 850 m.	Switzerland	Concert	9.30 p.m.	300 Watts.
122	8.15	Zurich	— 515 m.	Switzerland	Concert	10.00 p.m.	500 Watts.
123	8.15	Leipzig	— 454 m.	Germany	Symphony Concert	9.40 p.m.	700 Watts.
116	8.30	Munster	— 410 m.	Westphalia	Classical Concert	10.00 p.m.	1.5 Kw.
220	8.30	Voxhaus	— 505 & 430 m.	Berlin	Evening Programme. Dance Music from 10.30 p.m.	Midnight.	700 Watts & 1.5 Kw.
174	8.30	Munich	— 485 m.	Bavaria	Concert	11.0 p.m.	1 Kw.
128	8.30	Radio-Paris	SFR 1780 m.	Clichy	Detailed News Bulletin	9.00 p.m.	8 Kw.

Ref. No.	B. S. T	Name of Station.	Call Sign and Wave-length.	Situation.	Nature of Transmission.	Closing Time or Approx. Duration.	Approx. Power used.
SUNDAYS (Contd.)							
129	p.m. 8.30	Ecole Sup. des P. et Tgs.	FPTT 450 m.	Paris	Concert or Lecture. May begin 15 mins. earlier or later	10.30 to 12 p.m.	500 Watts.
132	9.00	Radio-Iberica	RI 392 m.	Spain	Concert	Midnight	3 Kw.
130	9.00	Radio-Paris	SFR 1780 m.	Clichy	Concert, followed by Dance Music.	11.00 p.m.	8 Kw.
131	9.30	Petit Parisien	— 345 m.	Paris	Concert (Items announced in English as well as French).	11.30 p.m.	500 Watts.
133	11.00	Eiffel Tower	FL 2650 m.	Paris	Time Signal in Greenwich Sidereal Time (Spark).	3 mins.	60 Kw.
134	11.44	Eiffel Tower	FL 2659 m.	Paris	Time Signal in G.M.T. (Spark)	3 mins.	60 Kw.
135	12.57	Nauen	POZ 3000 m.	Berlin	Time Signal in G.M.T. (Spark)	8 mins.	50 Kw.

SPECIAL DAYS.

104	p.m. 5.00	Stuttgart	— 443 m.	Wurtemberg	Sat., Children's Corner	6.30 p.m.	1 Kw.
137	5.00	Lausanne	HB2 850 m.	Switzerland	Mon., Children's Stories	1 hour	300 Watts.
224	5.00	Munich	— 485 m.	Bavaria	Children's Hour	6 p.m.	1 Kw.
142	5.40	Ned. Seintoesl. Fabriek.	NSF 1060 m.	Hilversum	Mon., Children's Hour	6.40 p.m.	3 Kw.
203	6.00	Gotenborg	SMZX 460 m.	Sweden	Tues., Concert	8 p.m.	300 Watts.
140	6.15	Zurich	— 515 m.	Switzerland	Mon., Children's Corner	6.50 p.m.	500 Watts.
180	6.30	Belgrade	HFF 1650 m.	Serbia	Fri. Tues., Concert	1 hour	500 Watts.
221	6.45	Copenhagen	— 750 m.	Denmark	Thurs., Sat. Tues.—Concert	7.45 p.m.	2 Kw.
147	7.00	Stockholm	— 440 m.	Sweden	Wed., Thurs.—Concert Fri. & Sat.	8 p.m.	—
222	7.00	Ryvang	— 1025 m.	Denmark	Tues. & Fri.—Concert	8 p.m.	—
152	7.50	Ned. Seintoesl. Fabriek	NSF 1060 m.	Hilversum	Wed., Concert	9.40 p.m.	3 Kw.
151	8.40	Amsterdam	PX9 1050 m.	Holland	Mon., Concert	10.40 p.m.	600 Watts.
225	8.45	Le Matin	SFR 1780 m.	Paris	Sat., Special Gala Concert	11 p.m.	10 Kw.
223	9.00	Malmo	SASC 270 m.	Sweden	Thurs., Sat.—Dance Music	11 p.m.	500 Watts.
154	9.30	Petit-Parisien	— 345 m.	Paris	Tues., Concert (Items announced in English as well as French).	11.30 p.m.	500 Watts.
197	10.00	Breslau	— 418 m.	Silesia	Sat., Dance Music	11 p.m.	1.5 Kw.
210	10.00	Radio-Wien	— 530 m.	Vienna	Dance Music, Wed., Sat.	11 p.m.	1.5 Kw.
155	10.00	Radio-Paris	SFR 1780 m.	Clichy	Two Evenings per Week—Dance Music	10.45 p.m.	8 Kw.
226	10.30	Voxhaus	— 595 m.	Berlin	Thurs. & Sat.—Dance Music	Midnight.	1.5 Kw.

The following are German Relay Stations:—
 Kassel, 288 m., 1 kw. relays Frankfurt.
 Bremen, 330 m., 1 kw., and Hanover, 296, m., 1 k.w.; relay Hamburg.
 Nuremberg, 340 m., 1 kw.; relays Munich.
 Dresden, 262 m., mostly relays Leipzig.

SPECIAL NOTICE

The next issue of "Modern Wireless" will contain a full "How to Make" description of a

NINE VALVE CABINET SUPERHETERODYNE RECEIVER

By JOHN SCOTT-TAGGART, F.Inst.P., A.M.I.E.E.

The Receiver is the outcome of many months' experiment on this type of instrument, and gives remarkable results on the smallest frame aerial.



Spring

A wonderful time of the year—Spring! The promise of sunshine, the promise of flowers and the promise of the great outdoors. Let our hopes include music, song, dance and romance—through Sterling radio—this Spring!

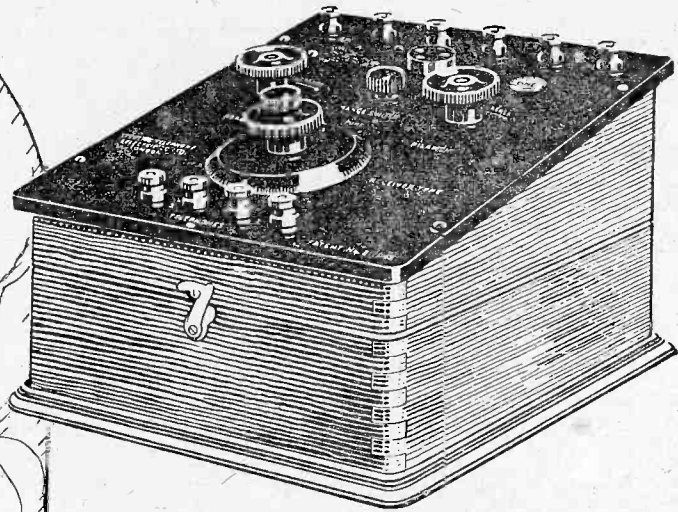

For you and yours!

Here is a radio receiver that pleases like the flowers of Spring, but the pleasure it brings lasts longer! With the Sterling "Anodion One" all the joys of broadcasting are for you and yours indoors and outdoors, through the Spring, through the Summer, and for the years to come.

These claims are no idle phantasy of the season, for Sterling have never made anything in radio that did not keep its promise. There is no one, whether radio expert or amateur, who has ever failed to receive through Sterling products the wonder and charm of music, song and interest with an efficiency that is without equal.

The truth of this claim is in your hands to test by inquiry where you will. Dealers are always happy to demonstrate Sterling products.

The "Anodion One" is a highly efficient one-valve receiver giving splendid results often at considerable distances under favourable conditions. Tuning is effected by means of a Sterling Square Law Condenser in conjunction with Sterling Tuning Units, the complete range available covering a wave-band of 275-7600 metres. The instrument is mounted upon a highly finished desk-type hinged cabinet. With B.B.C. coil, but without accessories. **PRICE £7:7:0**

At your radio dealer

A good time to buy

STERLING "ANODION ONE" VALVE RECEIVER

Advt. of STERLING TELEPHONE & ELECTRIC CO., LTD., Manufacturers of Telephones and Radio Apparatus, etc.
 Telephone House: 210-211, Tottenham Court Road, London, W.1
 Works: LAGENHAM, ESSEX.

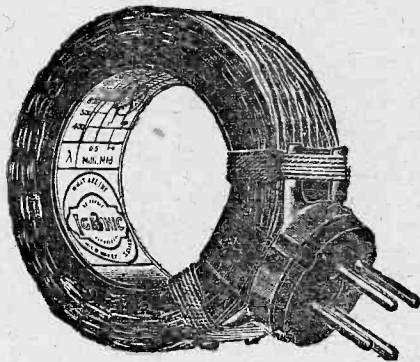

IGRANIC High Frequency Transformer



IGRANIC "E" Type Transformer

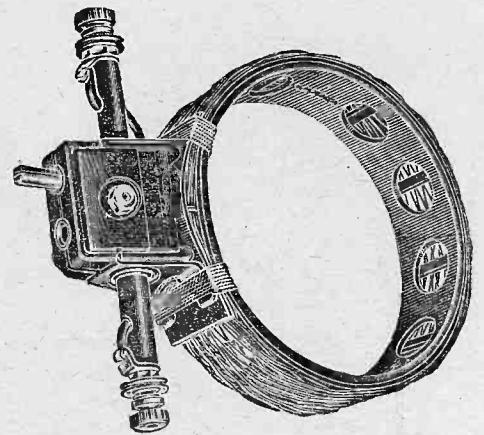

IGRANIC Unitune Coupler

The secret of their fine performance —is in the windings

In the case of both the Igranic High Frequency Transformer and the Igranic Unitune Aperiodic Fixed Coupler the world famous De Forest method of Honeycomb Duolateral winding is employed.

In the transformer this results in a highly inductive coupling being obtained and self-capacity is kept at a minimum—and so the maximum transference of anode potential fluctuations to the grid of the succeeding valve is assured with the minimum of distortion. The Igranic H.F. Transformer is made in four sizes: 250 to 500 metres, 8s.; 450 to 880 metres, 9s. 6d.; 800 to 1,700 metres, 11s.; and 1,500 to 3,000 metres, 12s. 6d.

The De Forest method is of particular advantage in the Unitune Coupler—a device specially designed for transatlantic and short wave reception—because minimum self-capacity in the coupler is so essential when high-frequencies, such as occur in short wavelengths, are involved. The Igranic Unitune Coupler combines the advantages of both direct and loosely

coupled methods of tuning without their attendant disadvantages. Made in two sizes—minor for 75–180 metres, 7s. 6d., and major for 300–600 metres, 9s. The Igranic E. Type Audio-frequency Transformer has a coil wound by a patent cotton interweave process, and the primary and secondary windings are so disposed with relation to the iron circuit that distortion is avoided. Windings are of ample cross-section and have a current carrying capacity of 20 milliamperes. Each transformer is subjected to a flash test of 2,500 volts alternating potential between windings and between windings and frame, and is suitable for anode potentials up to 150 volts. This audio-frequency transformer is obtainable in 1–5 ratio for first stage of amplification, 21s., and 1–3 ratio for second and subsequent stages, 19s. 6d. Only the finest material can stand the tests to which Igranic Components are put before leaving the works and it is therefore not to be wondered at that you will build a better set with Igranic Radio Devices.

Write for list No. Z 448.

IGRANIC RADIO DEVICES include Honeycomb, Duolateral Coils, Fixed Condensers, Filament Rheostats, Intervolve Transformers, Variometers, Vario-couplers, Bi-plug Coil Holders, Tri-plug Coil Holders, Battery Potentiometers, Vernier Friction Pencils, Electric Soldering Irons, etc. All carry the IGRANIC guarantee.



149, Queen Victoria St. LONDON WORKS BEDFORD

Branches:
Birmingham: 73-74, Exchange Buildings.
Cardiff: Western Mail Chambers.
Glasgow: 50, Wellington Street.
Leeds: Standard Buildings, City Square.
Manchester: 30, Cross Street.
Newcastle: 90, Pilgrim Street

These are the foundations of a BETTER set



IGRANIC "E" Type Transformer.



IGRANIC High Frequency Transformer.



IGRANIC-FRESHMAN Fixed Condenser.

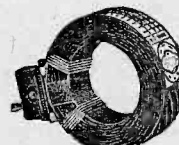

IGRANIC Honeycomb Duolateral Coil.

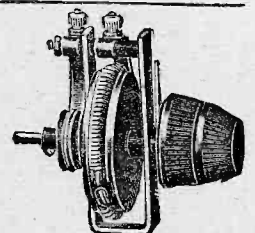

IGRANIC Rheostat (Vernier type).

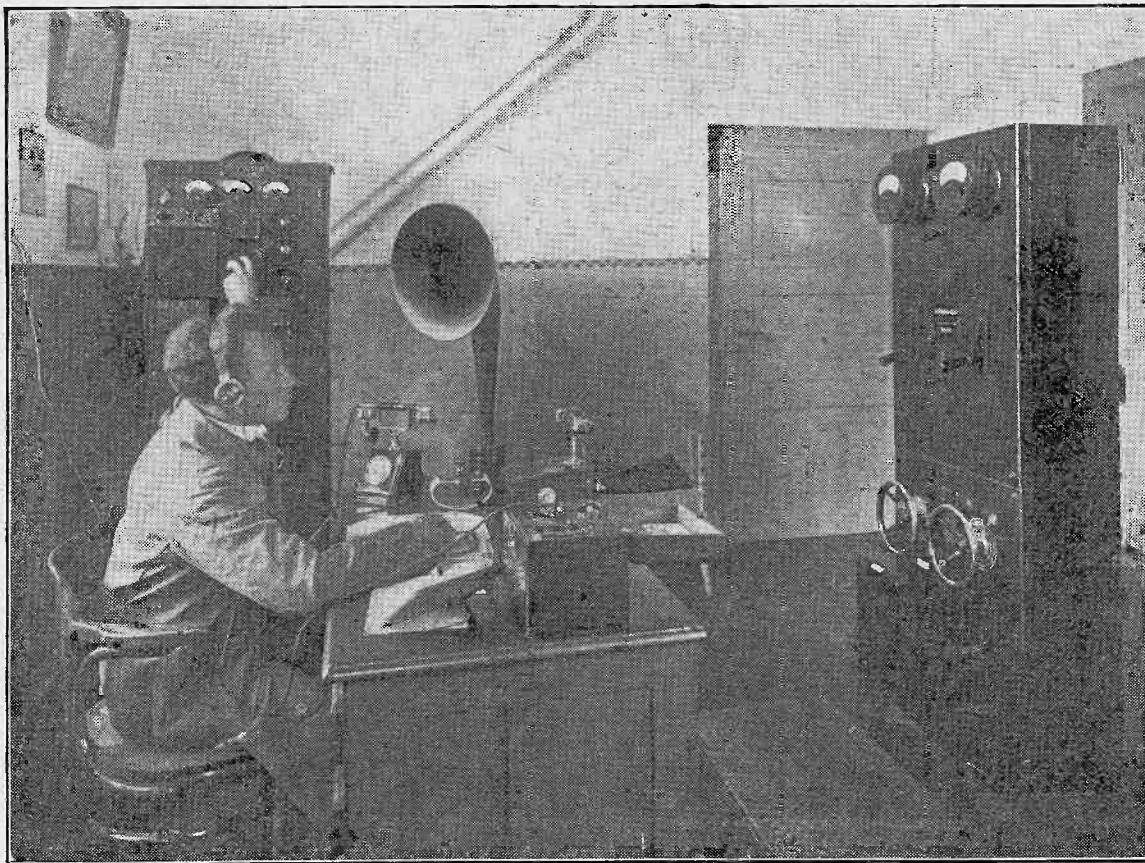

A view of the interior of the Zurich Broadcasting Station, a description of which appears below.

The Zurich Broadcasting Station.

By CAPT. L. F. PLUGGE, B.Sc., F.R.Met.S., F.R.Ae.S.

In this article our Continental Broadcasting Correspondent describes in an interesting manner another of his visits to a celebrated Continental station.

ZURICH is a very pretty town situated on the German side of Switzerland, and on the northern apex of the great Zurich Lake. It is not more than 25 miles as the crow flies from the German frontier.

Although broadcasting stations exist both at Lausanne and Geneva, the Zurich station is the only Swiss broadcasting station which may consistently be heard in Great Britain at present. There are several interesting features about the Zurich Broadcasting Station which are noteworthy. In designing the station, which is run by the Radio Genossenschaft Co., it was borne in mind that the inhabitants of the town of Zurich would most likely want to listen to foreign stations as well as their local one,

and for this reason, among others, it was decided to place the transmitting station some five miles out of the town, although the studio is located in the centre of Zurich.

Transmitting Equipment

This procedure has done away with the trouble of interference from the near station sending out on full power when the amateur is trying to tune in a distant station on a similar waveband. This difficulty is much experienced and complained about by the inhabitants of our great cities, where in most cases, and in particular London, the transmitting station is placed in the centre of the town. In the case of Zurich there was another distinct advantage in placing the station outside the town and near

the little village of Hongg, where it is situated, as the site chosen is some 500 feet above the level of the town and consequently about 1,800 feet above sea level. It is unnecessary to dwell upon the value of such a vantage point with regard to distant reception, and no doubt this goes much towards assisting this station in being heard over such great distances although using so small a power. There is another reason, however, for this, and that is, undoubtedly, the transmitting gear used. This gear is the standard Western Electric 500 watt transmitting equipment. Those who are used to tuning in Continental stations will have heard several stations which are equipped with this gear, and among these is the "Petit Parisien,"

which has often been received in this country on sets which are sometimes not able to receive more than one or two B.B.C. stations.

The Aerial

When the Zurich station began transmitting it used a wavelength of 800 metres, but this was subsequently reduced to 650 metres. The jamming from shipping on this wave, however, decided the Chief Engineer to reduce the wavelength again, and 515 metres is now used.

The aerial, which is supported by two lattice steel towers 65 metres high and 140 metres apart, consists of a six wire cage, six feet in diameter, the horizontal part being approximately 150 feet above the counterpoise. The total length of the aerial is 240 feet and the wires consist of seven strand 18 s.w.g., the overall diameter of the stranded wire being approximately 4 millimetres. As mentioned, a counterpoise is used instead of the usual earth connection. This counterpoise consists of a fan-shaped network of wires radiating from the transmitting equipment and consisting of single conductors of about two millimetres diameter. They are supported by wooden poles and steel supporting wires and form a sheet at about 15 feet above the ground level. The counterpoise is insulated from the supporting wires by small egg-type insulators, and the supporting wires are fastened to the wooden poles by heavy porcelain insulators.

The Station

The transmitting gear is installed in a small concrete building situated at the foot of one of the towers. It only contains two rooms on the ground floor, in one of which the transmitting gear is installed, together with the speech amplifier and power panel. In the second room, the motor generator set, line switches, battery charging gear, etc., are housed. There is also a small upper story in the building which contains the storage battery for the speech input equipment and also a bedroom for the station operator.

Aerial Lead-in

The high frequency connections from the aerial and the counterpoise to the transmitting gear are made of $\frac{3}{8}$ inch copper tube. No lead-in insulator is employed, the copper tube being taken direct through a hole in a glass window. The lead down from the aerial is 150 feet long and consists of six wires of the same diameter as those used for the 90 feet of the horizon-

tal portion of the aerial. The upper part of the lead down is arranged in the form of a small cage about 10 centimetres diameter, and in the lower half the wires forming this cage are bound together in a compact cable with a view to reducing the capacity of this lower portion, which joins on to the copper lead-in tube previously mentioned. The natural wavelength of the aerial system is approximately 500 metres.

The Studio

The Zurich studio is on the fourth floor of a large building in the Lindenofstrasse, and is connected to the transmitting station by means of a cable in the city itself, by overhead wire to within some 20 yards of the station, whence it is again brought underground by means of a second cable to the speech input amplifier in the transmitting room.

Some considerable changes are at present under consideration with regard to the studio arrangement, but when I visited the station a couple of months ago arrangements were quite satisfactory. The control room was, as usual, adjoining the studio. An interesting device, which I have not seen in use at 2LO, and which I found very helpful whilst broadcasting, would warrant description. It consists of a large panel containing eight small compartments which could be separately lit up. On the glass panel of each of these compartments indications such as "Speak up," "Stand further away from the microphone," "Speak slower," etc., could be flashed from the control room.

Afternoon Transmissions

All those who have visited Zurich, and many travellers do this on their

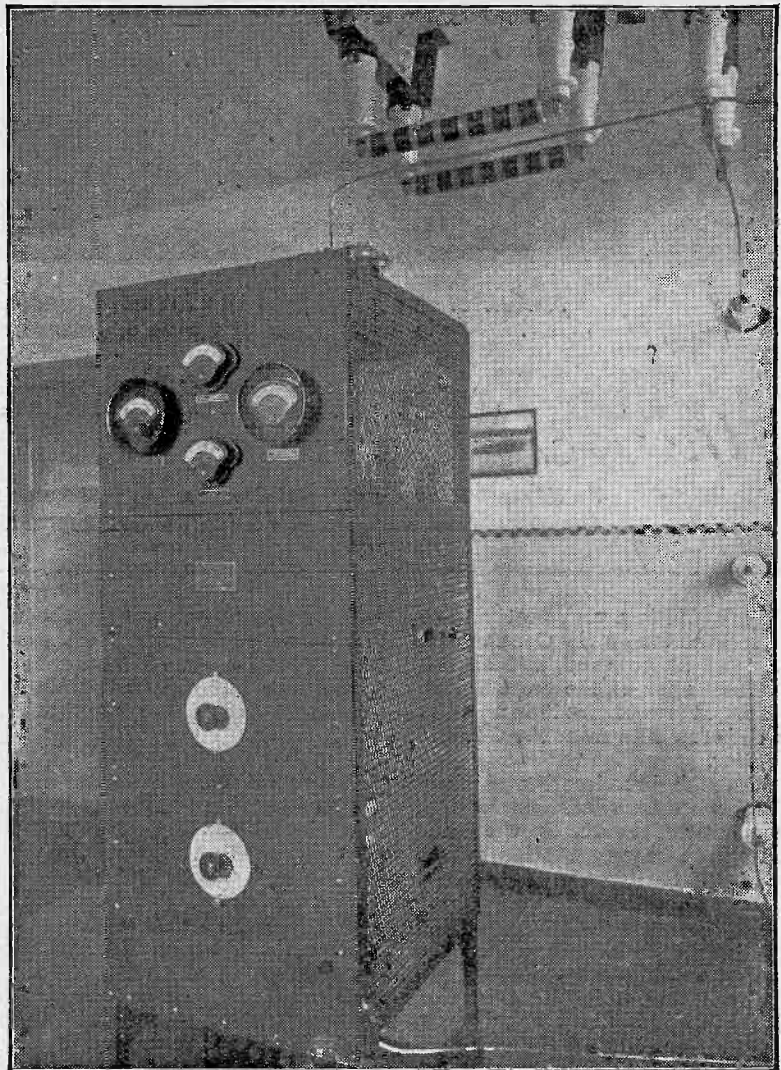

The transmitting panel at the Zurich station.

Sharp Tuning

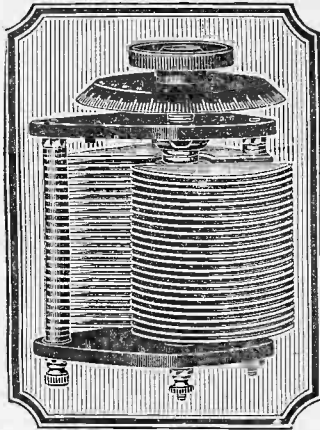

Provided you are using good coils, your receiver should tune sharply. If your coils are low loss then flat tuning is caused by using inefficient condensers. Good condensers make tuning a pleasure. Sharp—razor sharp tuning—requires a tuning condenser which is designed with an almost zero minimum capacity and a guaranteed maximum; very low dielectric losses and negligible resistance to H.F. currents. Experimenters continually express their high appreciation of J.B. Variable Condensers.

Among the popularly-priced, no better instrument can be procured. Zero minimum, guaranteed maximum, low loss, and mechanically perfect summarise the J.B. A more precise instrument cannot be obtained. Square Law or Standard as you may desire.

SQUARE LAW				STANDARD			
.001	.. 9/6	.00025	.. 6/9	.001	.. 8/6	.00025	.. 5/9
.00075	.. 9/-	.0002	.. 5/6	.00075	.. 8/-	.0002	.. 5/-
.0005	.. 8/-	.0001	.. 5/3	.0005	.. 7/-	.0001	.. 4/9
.0003	.. 6/9	Vernier	.. 4/6	.0003	.. 5/9	Vernier	.. 4/-

From all dealers throughout the world, or in cases of difficulty send direct.
Post :—One, 6d. ; Two, 9d. ; Three, 1s.

JACKSON BROS.
8, POLAND ST-OXFORD ST
LONDON - W.1. Telephone:-
(First Floor) GERRARD 7414

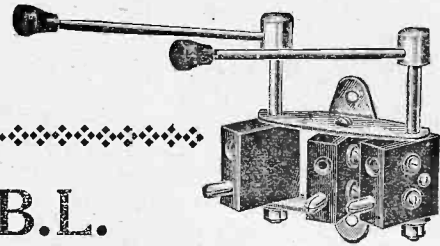

B.B.L. Coil Holder

The nickel-plated extended handles, fittings and ebonite, are assembled with minute care; the finished holder being an efficient and worthy fitment for any set, whilst the very low price at which it is marketed will appeal to all. Here you are offered both quality and price advantage.

Kindly order from your local Wireless Dealer. We cannot supply direct.

No. RC50/40 2-way, panel mounting .. each 3/9
No. RC50/41 3-way, panel mounting ... each 5/-

Brown Brothers

— Allied Companies —
THOMSON AND BROWN BROTHERS LTD
BROWN BROTHERS (IRELAND) LTD
Wholesale only. Head Offices and Warehouses:
GREAT EASTERN STREET, LONDON, E.C.2.
118, George St., EDINBURGH, and Branches.

Let distortion be in the other fellow's set

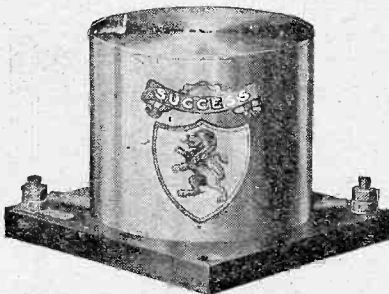

As used in the Choke Amplifier Unit, described by John W. Barber in the April issue of the "Wireless Constructor."

Price 10/6



WITH the passing of such phases as the "itch for distance" comes the more tangible pleasure of attaining good loud-speaker reproduction.

With the provision of the scientifically and accurately designed Success Choke it would be interesting to conduct experiments to prove if any other method of audio-frequency amplification could give greater purity.

There is no secret in the performance of the Success Choke. That music and speech are faithfully reproduced, with an absolute dead silent background, that there is a complete absence of raucous penetrating mush and curious distorting noises conspicuous in many receivers, comes not by accident.

The scientific facts which have guided the design of the Success Choke in conjunction with an intense criticism that it should reproduce with greater fidelity than any component then available, indicates to some measure, that in the Success Choke you have a remarkable instrument.

With the Success Choke, artist, orchestra and speaker are brought to your bedside.

BEARD & FITCH, LTD.
34, AYLESBURY ST., LONDON, E.C.1.
Telephone: Clerkenwell 8941,
North of England Branch:
1, DEAN ST. PICCADILLY, MANCHESTER.
Telephone: Central 8240.



Regd. No. 703507.

PROVEN SUPER EXCELLENT.

Granted that you have carefully adjusted your receiver to perfect balance, we ask you to concentrate your experience and judge for yourself the performance of the SUPER SUCCESS. It gives you power—shorn of any penetrating tone-destroying mush.

THE SUPER SUCCESS (All Black) L.F. Transformer - - - - - 21/-
THE SILVER SUCCESS L.F. Transformer. For Second Stage - - - - - 17/6

25 Years' British Manufacturing Experience.

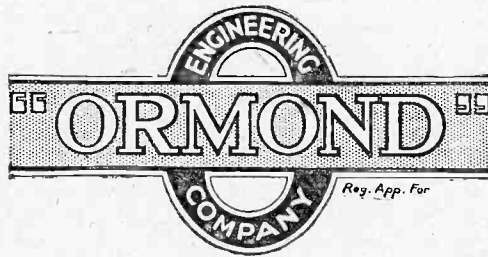

The "Square Law" Type Variable Condenser

THE use of a "Square Law" Condenser renders the tuning of a Receiver a very simple matter indeed. A calibration chart may be made by the following simple means:—
Tune in a station of known wavelength on the lower part of the condenser scale and plot it on the chart. Repeat this process with another station of known wavelength which is received on the upper part of the condenser scale. Draw a straight line through the two points and the chart is complete. Owing to details of its design, this type of Variable Condenser possesses a negligible minimum capacity, and the specially shaped vanes give an ease of control which is entirely unknown to users of the ordinary type.

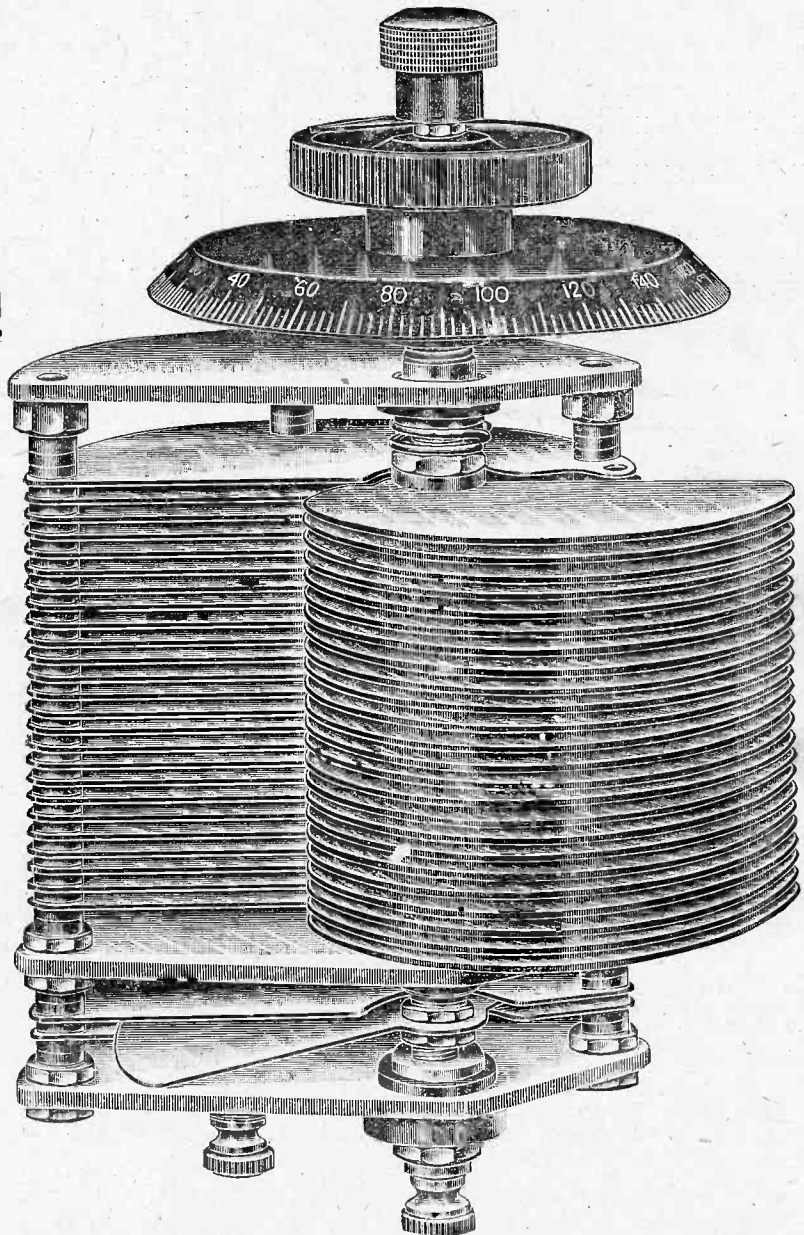
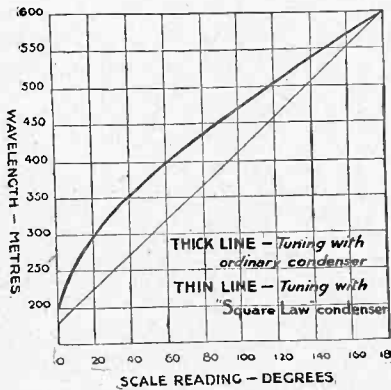

PRICES :

Without Vernier.		With Vernier.	
*001	.. 9/-	*001	.. 10/6
*0005	.. 8/-	*0005	.. 9/6
*0003	.. 7/6	*0003	.. 9/-
*00025	.. 6/6	*00025	.. 8/-

DELIVERY FROM STOCK.

All Cheques and Postal Orders should be crossed and made payable to "The Ormond Engineering Co."

We specialise in turning Brass and Steel Screws and Machined Parts and Accessories of all descriptions.

Write for our New (1925) Catalogue. Trade Terms on Request.

ORMOND
ENGINEERING CO.,
199-205, Pentonville Rd.,
King's Cross, London, N.1

Telegrams :
"ORMONDENGI, KINCROSS."

Telephone :
CLERKENWELL 9344 (3 lines).

FACTORY :
Whishin Street, CLERKENWELL,
E.C.1.

Look for the name "ORMOND" on all our Products !

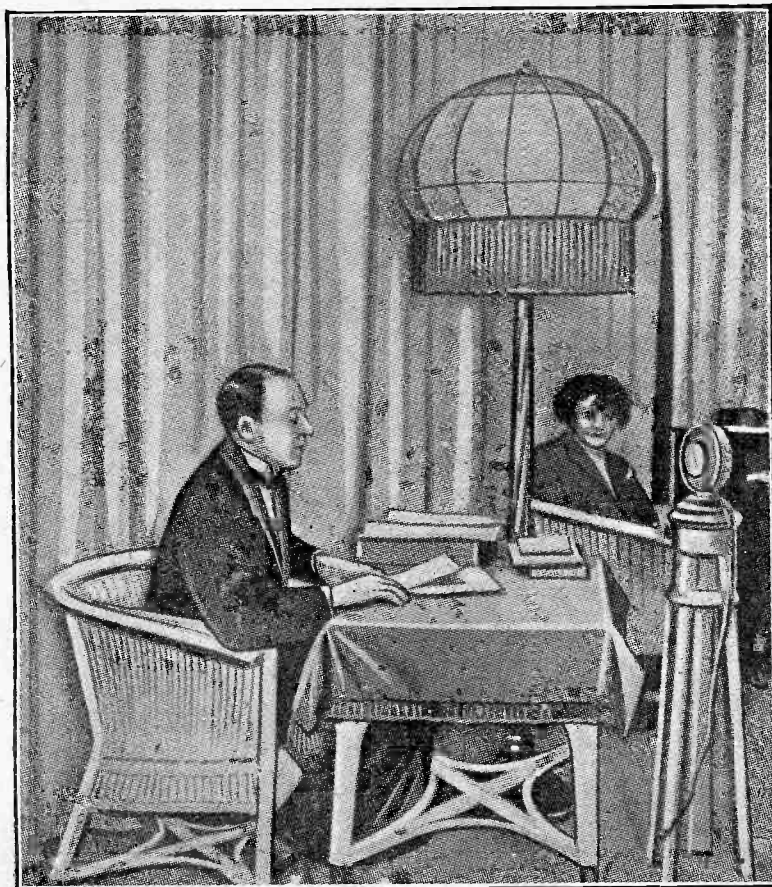

The author seated before the microphone on the occasion of his talk from the Zurich station.

*A Fair Reader's
Success*

SIR,—This letter is long overdue, as I have been using the "All-Wave Receiver" described by Mr. John Scott-Taggart, ever since March, 1924, and yet I can only give a partial report, as I have not yet managed to get a third valve. As detector or detector and L.F., I think the set is very good, especially as, in a way, it is only a makeshift not to use all three valves. I get 2ZY (15 miles) at v. ry good strength. I can make it too loud for comfort. 6LV (15 miles) is hardly any different, and neither station interferes with the other. I have had, at different times, every main B.B.C. station on the two valves. Leeds and Nottingham, also 5XX and Radio-Paris, come in, using Mr. Harris' special coil at good one valve strength. I also get several European stations, but never manage to work out who they are, except Petit Parisien, L'Ecole Superieure, Madrid, and, I think Zurich on Sunday. I have used a Peto-Scott low frequency transformer, Raymond condensers, Lissen Junior rheostats, Lissen gridleak, home-made basket coils wound with 20 S.W.G., and C.A.T. The selectivity is excellent, but having used it for a year, I have got so used to it that I want a change, so I am now making the "Twin-Valve" set.

Just before Christmas I made the single-valve cabinet set, in the December *Wireless Constructor*, for a friend, and he is delighted with it, as he seems to get in St. Helens anything he wants, and it is very selective.

I think, also, you would like to know of another of your feminine (yes, I'm a "she") readers. A small friend of mine, aged 15, at Christmas-time made, under my eye, Mr. Redpath's "Home" three-valve receiver, and it is a great success. She has soldered every joint, and the set is really well made. She has now on hand the two-valve set out of the January *MODERN WIRELESS* for her grandfather, and she is going to try to use square wire.

I must apologise for taking up so much of your time. Betty and I make our own cabinets and coils, as we aren't either of us well off! She takes the *Constructor*, and I have the other two from No. 1. All I know I have learnt from your papers and books.—Yours truly,

(Miss) DORIS M. DEWSE.
Wigan, Lancs.

way to St. Moritz, know the beautiful hotel, situated at the foot of the Zurich Lake, called Hotel Baur-au-Lac, and its well-known orchestra. This orchestra is broadcast regularly every afternoon by the Zurich station, and in the hotel lounge the standard push pull carbon microphone can be seen. The four-valve speech amplifier is housed in the cloakroom. In regard to these afternoon concerts, I would like to point out a serious fault, and that is the very long intervals which take place between items and during which no announcements are made. This wearies the listener and makes it exceedingly difficult for the distant listener to know with certainty the station he has tuned in. I would suggest that the items might be made shorter and the intervals as well, and, if possible, an occasional call given out, either at the hotel or from the transmitting station, for the benefit of listeners in this country and other distant listeners.

Conclusion

For some time the programmes, although of a classical nature, have been rather short, and some great improvements have been made

of late in this direction, for which all thanks are due to Mr. Speorri. Mr. Speorri, secretary of the Radio Genossenschaft, who has the welfare of Zurich listeners at heart, spares no effort in providing them with the very best programmes available. Apart from transmissions from theatres, he has also arranged some re-broadcasts of Chelmsford, which he receives on a three-valve set with very good results. Several performances of the Zurich State Opera have been relayed by the Zurich station, including one on the 9th of last month, when the opera "Tannhauser" was broadcast. This performance I received in London without any interference, at about normal crystal strength of 2LO, on my Supersonic heterodyne, using a 15' frame aerial and only two stages of intermediate amplification. The London station, only half a mile away, was entirely eliminated. The Zurich station is remarkable for the purity of its modulation and the absence of any noises in the carrier wave. This is so much so that, using a crystal receiver in the transmitting room itself, it was found impossible to detect if the carrier wave was being transmitted or not.

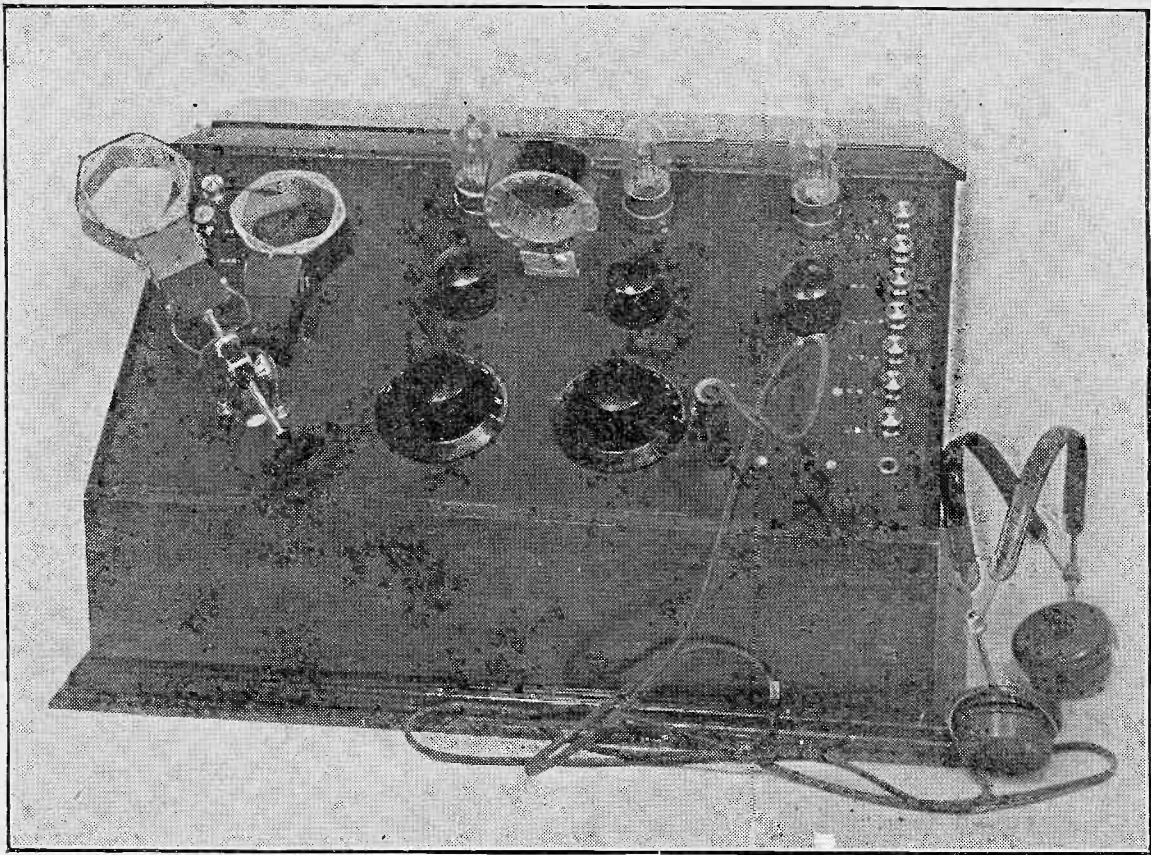

The "General Purpose Three"

By A. JOHNSON-RANDALL.

A three-valve receiver, eminently suitable for all-round work, capable of working a loud-speaker up to a distance of 20-30 miles from the local station. Good tele phone reception of all the B.B.C. main stations and most of the Continental is obtainable in favourable conditions.

IF I were asked, "What is the most popular type of receiver for all-round work?" I would most certainly reply: "A straight three-valve set consisting of a detector valve preceded by one stage of high frequency and followed by a single stage of low-frequency amplification."

This arrangement is probably the most useful combination utilising three valves that it is possible to obtain.

Considerations in Design

To commence with, what are the main points which govern the design of a general purpose receiver? They are, first, the set must be simple to understand, to construct, and to operate; second, it should be economical both in first cost and in maintenance; third, it must be suitable for general long-distance work on the telephones, and it must be also capable of operating a loud-

speaker efficiently on the local station. For long-distance work we need a stage of high-frequency amplification, and for loud-speaker

work it is essential that we employ at least one stage of low-frequency amplification; hence three valves is the smallest number we can use.

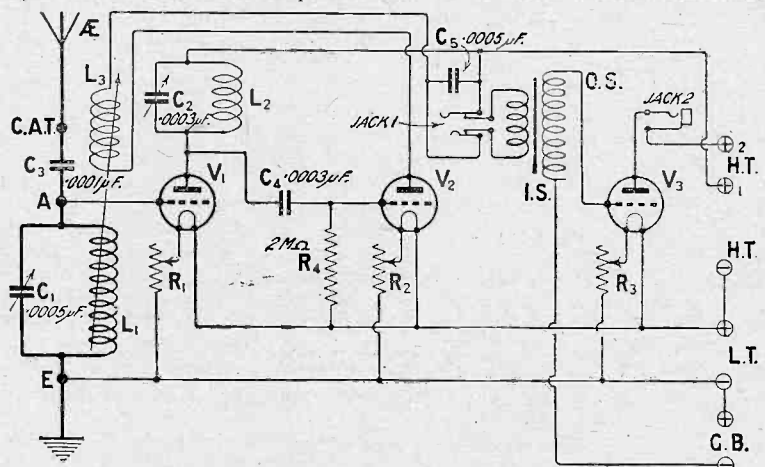

Fig. 1.—The theoretical circuit diagram. To cut out the low-frequency stage it is only necessary to insert the telephone plug in Jack No. 1.

LISSENIUM



LISSEN REACTANCE

150—10,000 metres

**LISSEN ONE HOLE
FIXING OF COURSE.**

For your H.F. work *The H.F. Unit to use in T.A.T. circuits*

THE semi-aperiodic stages of H.F. in the T.A.T. circuits should be the LISSEN REACTANCE (patent).

With its Reactance and capacity values on each tapping point arranged to give just that degree of damping which keeps the set stable without any sacrifice of efficiency, with its windings and whole design balanced, the degree of amplification obtained is surprisingly high for H.F. work. The purity of reception—the convenience in use (for it covers an extremely wide wavelength range, despite its compact form)—with its internally connected switch, making it easy to cover each wavelength band quickly—it is highly recommended for these circuits.

The receiver fitted with LISSEN REACTANCE will pick up distant signals, and build them up, passing them powerfully on to the next valve. Simplicity itself to fit, connect and use. It will make your T.A.T. receiver powerful. It is self-tuned, but a separate condenser may be fitted if desired (preferably use the LISSEN VERNIER, price 12/6, specially designed for fine tuning in H.F. circuits).....**PRICE 19/6**

LISSEN Neutrodyne Condenser

The action of the LISSEN NEUTRODYNE CONDENSER is particularly smooth and regular without any looseness or backlash, but is sufficiently firm to ensure that the condenser will remain indefinitely at any capacity to which it is set. A long control knob is fitted in order to overcome the risk of hand capacity effects when making adjustments.

Mounted by the *Lissen One Hole Fixing Method*, it occupies a space of less than 1 in. dia-

meter, and is only 1¼ in. long under panel.

The LISSEN NEUTRODYNE CONDENSER is a high class component, totally enclosed, with nothing to get out of order. **PRICE 4/6**

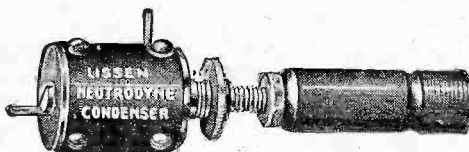

LISSEN LIMITED,

20-24, WOODGER ROAD, GOLDHAWK ROAD,
SHEPHERD'S BUSH———LONDON, W.12.

Telephones—Riverside 3380, 3381, 3382, 1072.

Telegrams—Lissenium, London.

VOLUME

THE
 great cathedrals
 of the world were built
 by men who loved their
 labour. They sought to express
 the beauty and lofty grandeur that
 is associated with architecture,
 and they were successful. You
 can have beauty and grandeur in
 the volume of your loudspeaker
 reception. Just take out your last
 L.F. stage valve and insert a
 MULLARD D.F.A. MASTER VALVE.
 These valves have been specially
 designed for maximum power
 work with a low temperature long
 life filament for minimum current
 consumption.

MULLARD D.F.A.O. for 4 volt
 accumulators, 26s. each.

MULLARD D.F.A.I. for 6 volt
 accumulators, 30s. each.

MULLARD D.F.A.3. for dry cells
 or accumulators, 6 volts, 32s. each.

Ask your Dealer for Leaflet V.A.4

Mullard
THE MASTER VALVE



Advt. The Mullard Radio Valve Co., Ltd. (M.W.), Nightingale Works, Balham, London, S.W.12.

Switching

To increase the sphere of usefulness of the receiver it is desirable that some form of switching device be incorporated so that the number of valves in use can be varied. But, unfortunately, switching on the H.F. side is not usually very effective, on account of the instability caused by its use. On the L.F. side, however, the problem is more simple, and it is therefore wise to arrange some method whereby the set may either be used as a two-valve receiver consisting of a high-frequency stage and a detector, or as a three-valve set utilising the low-frequency stage. If separate H.T. tapings are employed it is often a difficult matter to arrange the usual form of "lever" switching successfully, but the difficulty may be easily surmounted by the employment of jacks and telephone plugs. There seems to be a certain dislike for the use of jacks in this country, but I feel sure that once the sceptic tries this method he will never return to the more common forms of L.F. switching. It is a receiver of the general purpose type embodying the above points that I am about to describe.

Self-Capacity

Readers should bear in mind that in cases where they are situated within a short distance of the local station, it is unnecessary to use the H.F. valve in a conventional straight circuit, as the filament may

be turned out and signals still be received, in some circumstances with but small decrease in volume. The reason for this is that the incoming oscillations are by-passed by the small condenser formed by the internal capacity of the H.F. valve itself and its attendant casual capacities.

This may clear up a matter which so frequently mystifies readers who state that they still receive perfectly good signals even when the filament of the H.F. valve is turned off.

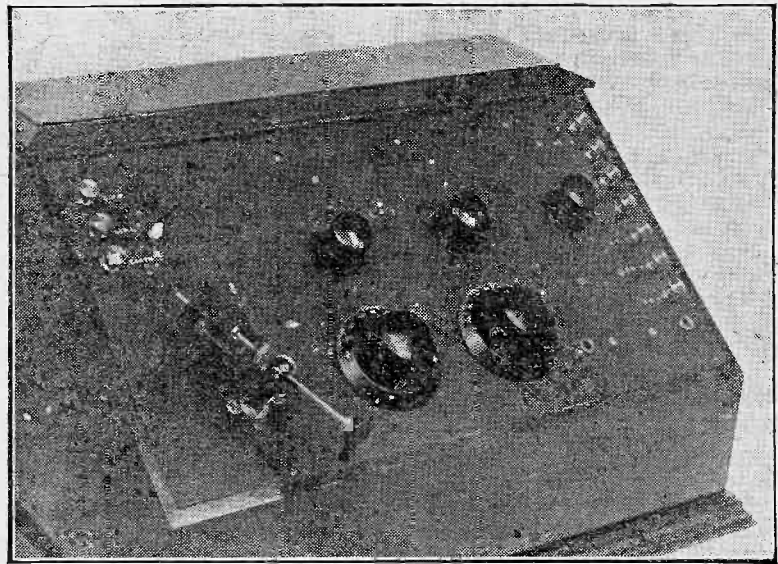

There is sufficient clearance for the largest types of plug-in coils.

The Circuit

The circuit chosen consists of an A.T.I. tuned by a .0005 μ F. square law pattern variable condenser connected in parallel. Constant aerial tuning is provided for those who prefer this method, and may be brought into use by connecting the aerial lead to the terminal marked C.A.T. on the panel instead of to that marked "Aerial."

The method of H.F. coupling used is the tuned anode, as it is almost an undisputed fact that this method gives greater amplification

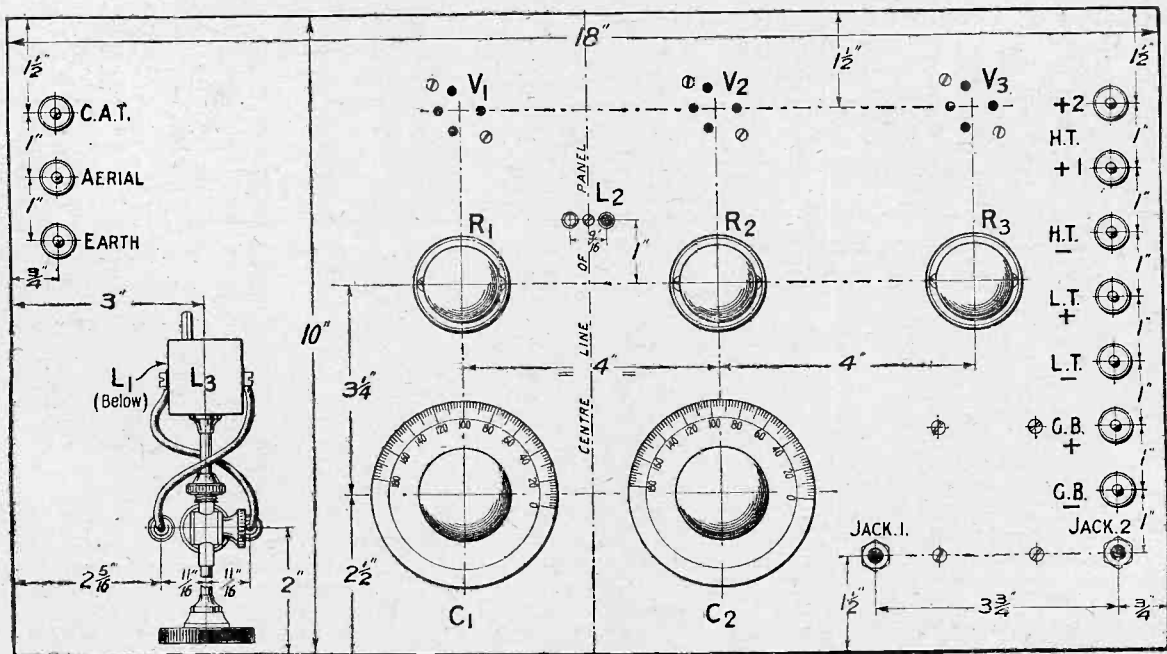

Fig. 2.—The lay-out of the front of the panel. Blue Print No. 107a, may be obtained from the Sales Dept. The aerial coil L1 is immediately below the reaction coil L3.

than any other ; although if more than one stage is used the receiver tends to become uncontrollable unless special precautions are taken. Two or three valves may be used as desired, as by means of two jacks the transformer-coupled stage of L.F. amplification may be cut out by the simple expedient of withdrawing the plug connected to the telephone leads from one jack and inserting it in the other. Two H.T. positive tapplings are provided, one of which is common to the first two valves, the other permitting the use of a higher H.T. voltage on the plate of the last valve.

Grid Bias

In order to ensure efficient operation on the L.F. side, provision is made for negative grid bias ; and it cannot be too strongly emphasised that full advantage should be taken

Drop across Rheostat

For example, in the case where an ordinary "R" type valve rated at 4 volts is used in conjunction with a 6-volt accumulator the drop across the filament resistance which is applied to the grid is 2 volts. If, therefore, our total grid bias should be 3½ volts, it is only necessary to plug in to the first tapping, which is 1.5 volts, on the grid battery.

Components Required

The following components are required, and if any departure is made from this list, the constructor should assure himself that those he chooses are of reputable make :—

- 1 Cabinet, sloping front to take a panel 18 in. by 10 in. by ¼ in. (W. H. Agar).
- 1 Ebonite panel, 18 in. by 10 in. by ¼ in. (Peter Curtis).
- 3 Dual rheostats (Burndept).
- 1 Two-coil holder (Polar Universal).

- 1 Plug (telephone) (R. A. Rothermel).
 - 1 .0005 μF fixed condenser (Dubilier).
 - 1 .0003 μF fixed condenser (Dubilier).
 - 1 2-meg. ohm grid leak (Dubilier).
 - 1 .0001 μF fixed condenser (Edison Bell).
 - 10 Terminals. Those used are Burndept and have 2 B.A. shanks.
 - 1 Set of Radio Press panel transfers.
- A quantity of square-section tinned copper wire and a few 4 B.A. and 6 B.A. screws and nuts.

Marking Out the Panel

Now take the panel, which should be guaranteed free from surface leakage, and mark out by means of a 12-inch steel rule and scriber to the dimensions given in blue print No. 107a or to those shown in Fig. 2. Having done this, drill the holes according to the instructions given

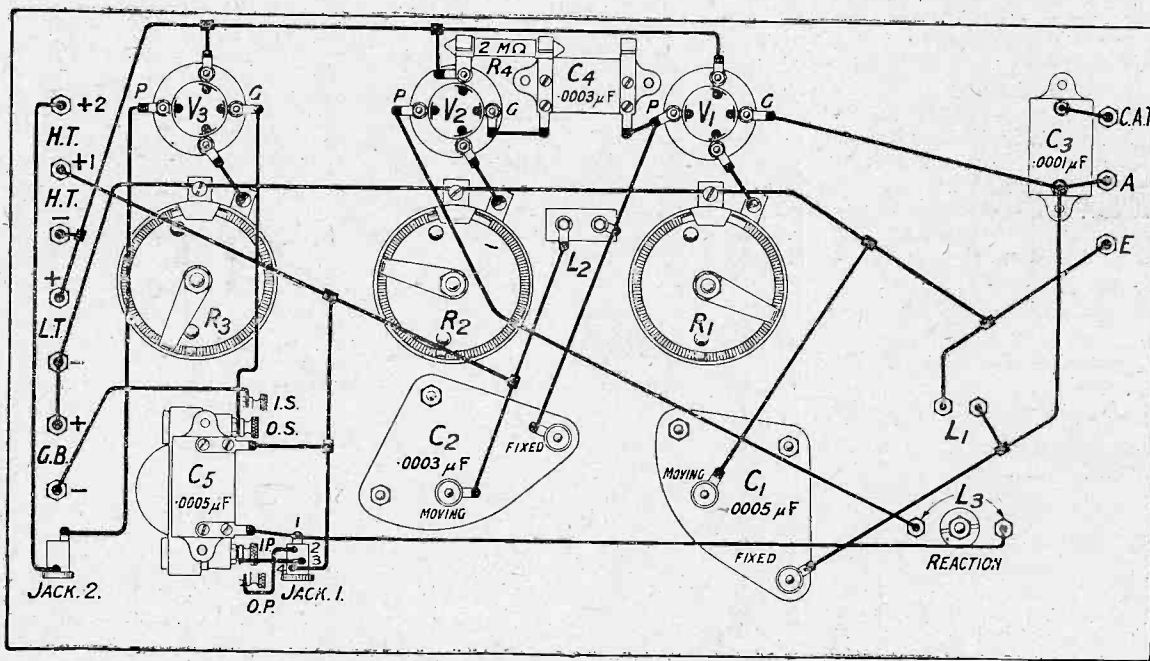

Fig. 3.—The wiring diagram, Blue Print No 107b. Jack No. 1, is for the purpose of cutting out the L.F. stage.

of this. It should be remembered that it is useless to expect good reproduction unless the H.T. and grid bias for the last valve are adjusted so that the operating point lies upon the correct portion of the characteristic curve for distortionless amplification. Of course, allowance must be made for the fact that the filament rheostats are connected in the negative L.T. lead. This automatically ensures a small negative bias on the grid of the L.F. valve, the magnitude of which is determined by the type of valve in use and the terminal voltage of the L.T. battery.

- 3 Valve holders (H.T.C.). Any type suitable for mounting beneath the panel can be used, and ordinary valve legs would be equally satisfactory and perhaps easier to mount in some cases.
- 1 .0005 μF sq. law pattern variable condenser (Jackson Bros.).
- 1 .0003 μF sq. law pattern variable condenser (Jackson Bros.).
- 1 Flush-mounting coil plug (Woodhall or similar type).
- 1 L.F. transformer (Royal).
- 1 Single-circuit open jack (R. A. Rothermel).
- 1 Double-circuit jack (R. A. Rothermel).

by the makers of the components on the paper templates supplied. The single-hole fixing condensers require a ⅜ in. hole, and the "Royal" transformer is secured by means of four No. 4 B.A. countersunk screws and nuts. Two ⅜ in. holes will also serve for the jacks, although this is larger than is necessary.

The terminals will have either No. 2 or No. 4 B.A. shanks, according to make and quality. Next commence the wiring, using No. 16 gauge square-section tinned wire and a hot iron of not less than 8 ozs. weight. A big iron is a distinct advantage, as it retains an even

Duodyne ^A Long Range LOUD-SPEAKER RECEIVER

Music all round the dial

"... With an indoor aerial on my Duodyne III. I receive all B.B.C., most Continental, and four American stations nightly, whether London is on or not. Tuning is absurdly simple, as there is music all round the dial."

Golders Green, N.W.

"The set goes very well indeed. ... I may say we got Havana, Cuba, the other morning, which none of the sets in this town have got yet."

C. J. H., Thurso.

"I must say I am delighted with mine. Nightly I tour the Continent."

Bush, Bradford.

"You will be interested to know that I received WGY Schenectady on a loud speaker almost as loud as 2LO on my Duodyne at Croydon."

J. A. Fowler, M.I.Mech.E.,
Wellman Smith Owen Engineering
Corporation, Ltd., Kingsway, W.C.2.

TWO STAGES OF H.F. AUTOMATIC TUNING.

Guaranteed Range under average conditions:

DUODYNE III Headphones	3/4,000 miles.
DUODYNE V Headphones	4/5,000 miles.
Loud-Speaker	1/1,200 miles.

The extraordinary range and simplicity of operation, exclusive to the DUODYNE RECEIVERS, must make an irresistible appeal in Imperial and Continental Markets.

THE DUODYNE Long-Range Receivers will discriminate between Radiola Paris and 5XX Chelmsford, or, used in conjunction with a CURTIS EJECTOR, will tune in any Broadcasting Station at will, while operating 1 1/2 miles from local Station or 200 yards from Relay Station.

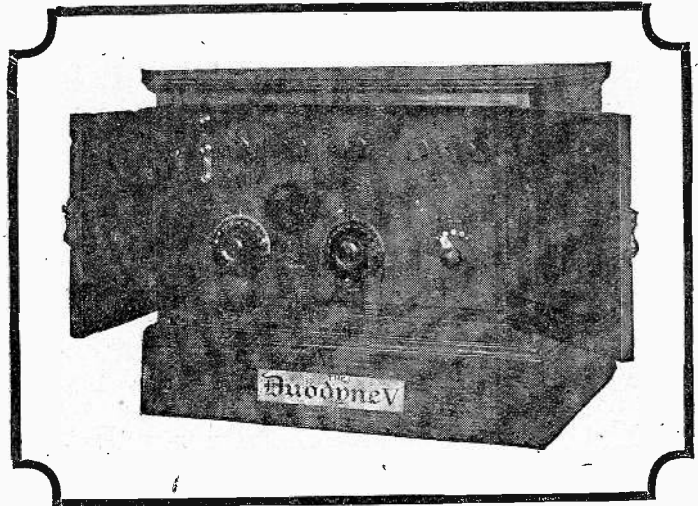

The DUODYNE CABINET.—The Duodyne V is supplied in French Polished Oak Cabinet with folding doors, enclosed valves and tuning coils. Self-contained batteries. Instrument only

£27

The DUODYNE III. (Instrument only) Panel Type

£10 0 0

The DUODYNE V. (Instrument only) Panel Type

£18 18 0

The DUODYNE PORTABLE IV

LOUD SPEAKER MODEL £21

Complete with D.E. Valves, all Batteries, Headphones, etc.

Guaranteed delivery at specified dates. Guaranteed range on self-contained aerial, 30 miles on 1 1/2 K.W. (An earth connection will double this distance.) Full particulars upon application.

THE MOST EFFICIENT AND POWERFUL PORTABLE RECEIVER ON THE MARKET
NOW ON DEMONSTRATION.

PARAGON EBONITE PANELS

Radio Quality Post Office Specification.

All "Modern Wireless" and Radio Press Panels supplied from Stock at 2d. per sq. in. Prices for drilling and engraving upon request.

Sold everywhere in Sealed Cartons only stamped Paragon.

PARAGON-CURTIS ONE PIECE MICA CONDENSER



MADE IN ONE PIECE: NO WAX.

Patentees and Manufacturers:
The Paragon Rubber Mfg. Co., Ltd.

UNCONDITIONAL GUARANTEE.

To replace free of all charge any Paragon Curtis One Piece Mica Condenser, which may break down or otherwise be defective from any cause whatsoever other than mechanical fracture for a period of five years from date of purchase. We have decided to extend to all users of Paragon Curtis One Piece Mica Condensers our maintenance guarantee given to users of the Paragon Curtis Submarine Cable Telegraph Condensers.

.00008 to .006	2/6 each.
Grid Condenser with clips	2/9 each.
Grid Leak	1/6 each.

BUILD YOUR OWN DUODYNE.

The wholly inexperienced can build this long range receiver with the aid of The Curtis-Duodyne envelope for home constructors, containing:—

1. Curtis diagrams for 3 and 5 valves.
2. Simplified Lay-out and Wiring Charts for 3 and 5 Valves;
3. Instructions for Operation.
4. Complete schedule of all material required.

16

SOLD EVERYWHERE.

Sales Organisation:

PETER CURTIS, LTD.

IN ASSOCIATION WITH
THE PARAGON RUBBER MFG. CO., LTD. HULL

75, CAMDEN ROAD, N.W.1.

Telegrams: "PARACURTEX" — Phone: NORTH 3112

BIRMINGHAM: 76, Newhall Street. Central 7236.
MANCHESTER: 312, Deansgate. Central 5095.

In replying to advertisers, use Order Form enclosed.

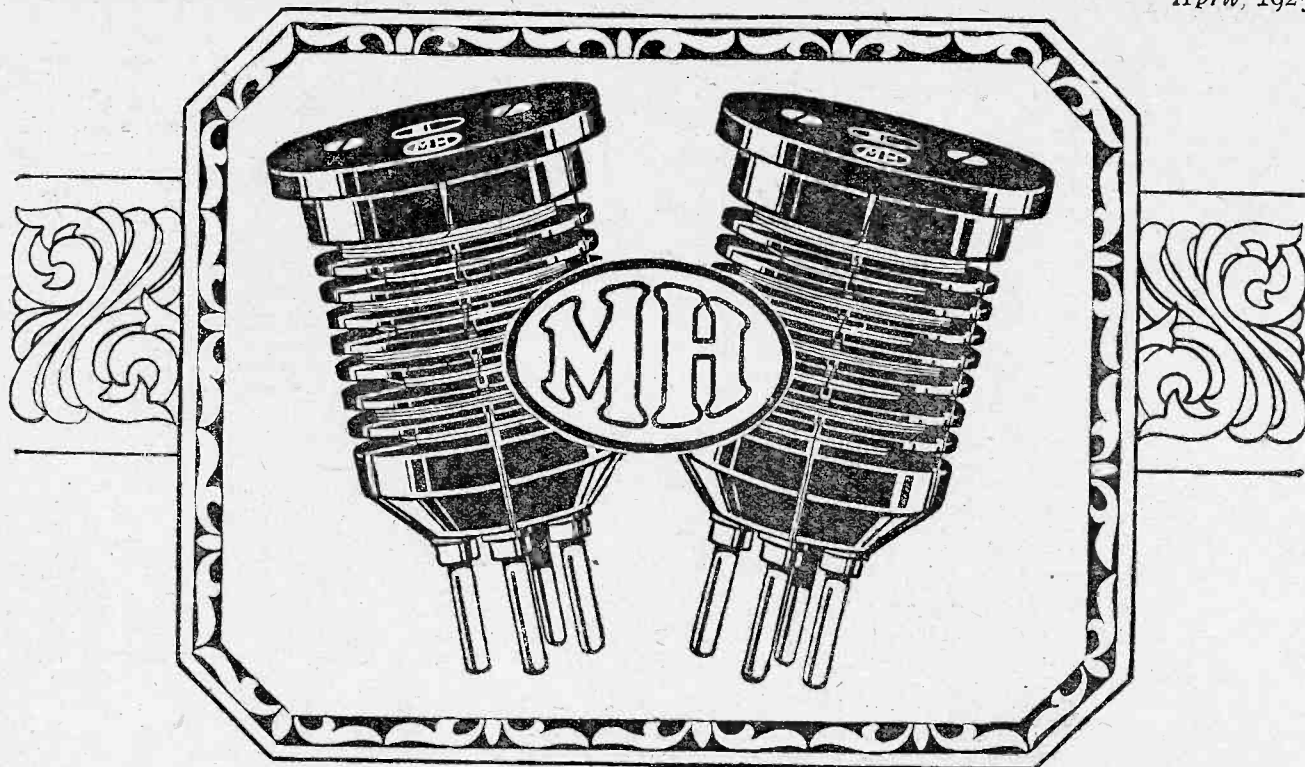

Never mind the aerial— Add a stage of H.F.

Have you been trying unsuccessfully to pick up a distant station, or having got it the reception is so faint as to render it a mere buzzing in the phones? This trouble is most often due to a mediocre aerial or inefficient components making long-distance reception an irritation rather than a personal radio achievement

It can be cured by adding a stage of H.F. Amplification, if the right components are used. The range of your receiver will then be increased considerably, selectivity assured, and for local reception the use of an aerial possibly dispensed with altogether.

To obtain one or all of these results it is absolutely imperative that reliable high

efficiency components be used. H.F. Transformers of M.H. manufacture are the first essential. These transformers are universally acknowledged to be the best.

Made of specially manufactured non-loss ebonite, precision machined and polished to the usual high finish of all M.H. products and with the windings carried in staggered slots, ensuring low self-capacity and high efficiency, they are of a well-balanced and pleasing appearance.

To ensure perfect matching they are subjected to a rigorous system of testing before being offered to the public and any not coming within extremely narrow limits are rejected. Matching is guaranteed, where specified.

Supplied in six ranges of wavelengths covering from 80 to 7,000 metres.

No. 00 ... 80 to 150 metres... 10/-	No. 2 ... 550 to 1,200 metres 10/-
No. 0 ... 150 ,, 300 ,, ... 10/-	No. 3 ... 1,100 ,, 3,000 ,, ... 10/-
No. 1 ... 300 ,, 600 ,, ... 10/-	No. 4 ... 2,500 ,, 7,000 ,, ... 10/-

A. 6, Neutrodyne Unit (Broadcast Wavelength) each 10/-
 The Complete Set in handsome case, Nos. 00-4 55/-

Any number of each Transformer can be supplied matched at NO extra charge, if requested at the time of ordering.

RADIO CORNER
179, STRAND, W.C.2.

L. M. MICHAEL LTD
Manufacturers of Wireless and Scientific Apparatus.

Write for instructive and interesting folder on "H.F. Amplification," also complete list of M.H. Components.

temperature so much longer than some of the ridiculously small ones sold by some dealers for wireless work. Use a minimum of flux, carefully washing off any traces afterwards with methylated spirit. A supply of small tinned soldering tags will be found very useful in all work of this description.

There are no special difficulties in the wiring up, except perhaps to

dull-emitter, will be suitable; but if a loud-speaker is going to be used and good distortionless reproduction is required, I recommend that a small power valve be used in the last socket. For use with a 6-volt accumulator a power valve of the B.T.H. B₄, D.E.5, or Mullard D.F.A. is capable of handling all the energy required for ordinary loud-speaker work in the house, and

specially for H.F. amplification will give excellent results; but, as stated above, a good general purpose valve will also give good results here.

Further Details

Having placed the valves in the sockets, turn the knobs of the rheostats and note whether the valves light up. All being well, connect up the H.T. battery, placing the positive plug connected to H.T.+1 in, say, the 50-volt tapping, and that connected to H.T.+2 in the 100-volt tapping if a small power valve is being used, otherwise from 70-80 volts will be suitable for ordinary valves. No hard-and-fast rules can be given respecting grid bias, as the type of valve and the H.T. are the two deciding factors, and here the maker's instructions should be followed. In no case should the voltage applied to the plates of any of the valves exceed that specified by the makers as the maximum. Place the telephone plug in the desired jack, according as to whether two or three valves are required, and place a No. 25 or 35 coil in the aerial socket and a No. 35 or 50 in the moving socket of the two-coil holder. For the upper band of B.B.C. wavelengths a No. 50 may give better results in the aerial socket. Place a No. 50, 60 or 75 in the anode socket, according to wavelength, and, keeping the moving coil well away from the aerial coil, rotate both condenser dials slowly until signals are heard. Now bring the moving coil nearer to the aerial coil. Signals should increase in volume on retuning slightly, and if this does not occur, rotate the moving coil through 180 degs., thus reversing the reaction. Signals should now increase in strength as the moving coil approaches the aerial coil, thus denoting that the reaction leads are now correct.

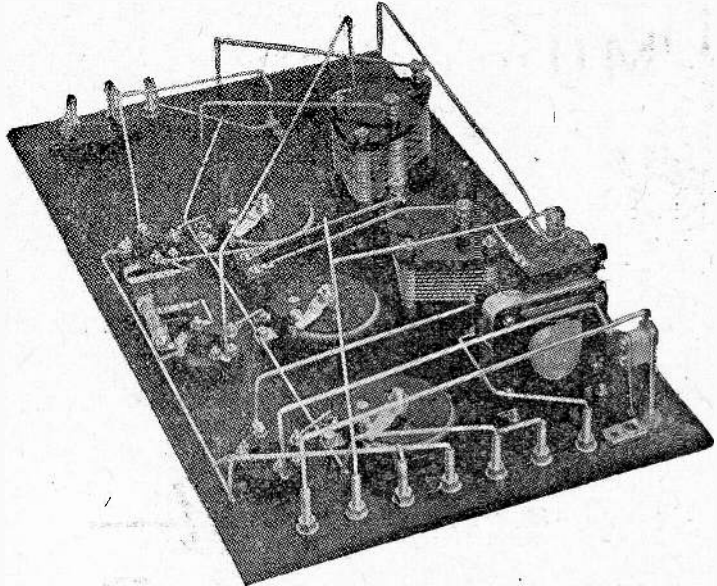

The connections to the battery terminals may be seen from this photograph.

the first jack, and a small sketch is shown in Fig. 4 in order to make any doubtful points clear. A small by-pass condenser of .0005 μF. is connected across the first jack, and must be joined to the two outer tongues and not to the inner ones. The value of this condenser is not critical, and the smallest size consistent with efficient reaction control should be used. I advise the use of clips for mounting the grid leak, as soldering direct to the end of the leak itself will in nine cases out of ten ruin it.

Be careful in mounting the flush mounting coil socket, and work to the template supplied by the makers. If no template is available, remember that the standard distance between centres for coil plugs and sockets is $\frac{9}{16}$ in. A $\frac{3}{32}$ in. drill will probably be found correct for most makes.

Operation

Connect up the L.T. battery to the terminals as marked on the panel lay-out, Fig. 2, and place three valves in the sockets. As dual rheostats are used, any type of valve can be used, and the following information may be helpful. In this receiver any good general purpose valves, whether bright or

these valves give very good results with 100-120 volts H.T. and about 6 volts negative grid bias. If a 4-volt accumulator is in use, then a valve of the D.E.4 type is very suitable; and in those cases where a 2-volt cell is used in conjunction with valves of the D.E.R. or B₃ type, then a small power valve of the D.E.6 type should be used. It should be noted that all the leading manufacturers make suitable valves of the above-mentioned types.

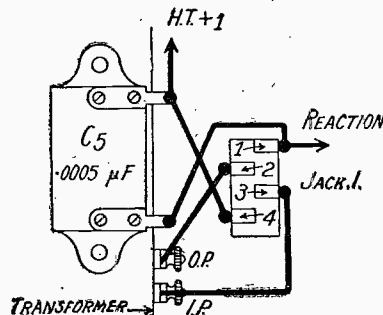
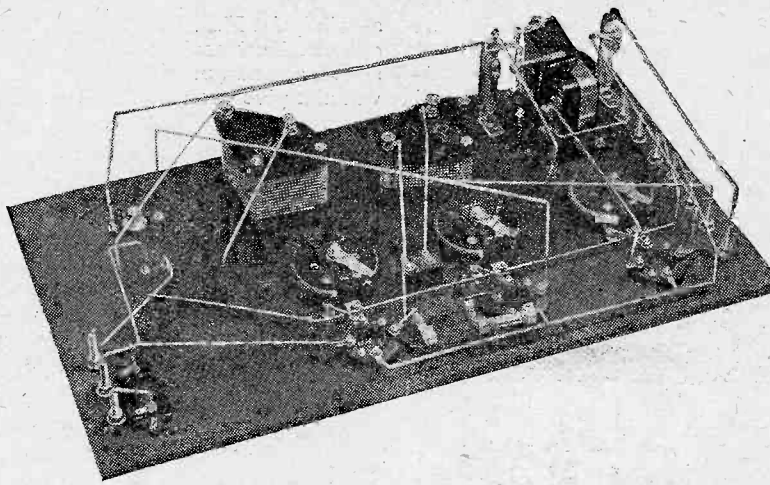

Fig. 4.—Details of Jack No. 1. 2 and 3 are the inner contacts.

Instructions regarding H.T. voltage and grid bias are given by the makers of the valves on the boxes in which they are packed. On the H.F. side, one of the valves made

Constant Aerial Tuning

The form of coil holder used is particularly useful for work with different types of coils, as it is not necessary to reverse the soldered leads on the back of the panel when desiring to reverse the direction of reaction. Experiment with the size of reaction coil until the best results are obtained. For 5XX and Radio Paris use a No. 150 coil in the aerial socket, a No. 100 for reaction, and a No. 200 or 250 in the tuned anode. For those who wish to use constant aerial tuning a No. 50 and 75 will cover the B.B.C. wave band, but as the use of this form of tuning in some cases makes the set very prone to oscillate, care should be taken and a small reaction coil



This photograph should be used in conjunction with the wiring diagram.

should be used. No condenser is shown in the theoretical diagram across either of the H.T.appings, nor is one included in the set. I recommend that these condensers should be treated as part of the H.T. battery unit itself. No condenser is connected across the last jack, as one is not really necessary for use with telephones; but for loud-speaker work some experiments should certainly be made with different sized shunt condensers, and the tone can be vastly improved if a suitable value is chosen. So much depends on the type of loud-speaker used, that no real information as to the proper value can be given here. Three good values to try are .004, .006, and .01 μ F.

Results

Results with any receiver are largely dependent upon local conditions, such as the type of aerial which can be erected and whether the district in which the constructor is situated is good or bad for reception generally. The results with this receiver were obtained at a distance of 15 miles S.E. of 2LO, using first, a single wire 100 ft. long aerial with an average height of 35 ft, well insulated and unscreened, and in conjunction with a low resistance earth. Second, an indoor aerial consisting of three 26 S.W.G. wires, each 15 ft. long, suspended 2 ft. below the ceiling of the drawing-room and uninsulated.

On the outdoor aerial 2LO is received at full loud-speaker strength without difficulty. At night Newcastle has been fairly consistently received at fair loud-speaker strength with London entirely eliminated. It is in fact generally audible on the loud-speaker on two valves only. Aberdeen and Birmingham have also been received at quite

good strength on the loud-speaker at night, although not so consistently as Newcastle. Bournemouth at times comes in at quite amazing strength, but it is difficult to eliminate 2LO, and fading is also very noticeable. A number of Continental stations are always audible at night on the loud-speaker, but generally speaking they are difficult to identify. No difficulty is, however, experienced in the case of Petit Parisien, as this station announces in English as well as in French, and it usually comes through at about the same strength as Newcastle.

The remaining B.B.C. stations are received at good telephone strength.

In daylight Birmingham is received at consistently fair loud-speaker strength, but unfortunately the Morse interference usually associated with this station when reception is carried out in the South of England is very troublesome.

On the indoor aerial 2LO is received at good strength on the loud-speaker; in fact there is not a big difference between the results on the indoor and outdoor aerial on this near station. The small aerial gives a very quiet background, and is at this distance preferable for general family use in an ordinary sized room. On Sunday morning, March 15, it was thought desirable to give the receiver a final test on real DX reception, and an attempt was made to receive America immediately after 5XX had finished his Transatlantic transmission, at about 1 a.m.

Transatlantic Reception

Previously it had been very amusing to hear the shrill scream of the local oscillators as they attempted to tune in Chelmsford's

harmonic on the broadcast band, evidently under the impression that they were receiving some distant transmission, probably America. At about 1.10 a.m. a piano was heard and a minute later the announcement that WBZ, the Westinghouse station, New England, would continue its programme from the Springfield studio, with another song. Reception was quite easily intelligible on the 'phones on two valves, and was audible on the loud-speaker using three. The coils used for all these tests were as follows: A Gambrell A or B in the aerial, a C for the tuned anode, and an "a" for reaction. Of the numbered coils use a No. 35 or 50 in the aerial, a 50 or 75 in the tuned anode with a No. 35 or 50 for reaction. The reaction coil is, of course, a matter for experiment, and with some aeriels a slightly larger one may be desirable. It is well to point out that should self-oscillation be experienced upon bringing the two tuned circuits into tune this may quite easily be controlled by using a small coil in the reaction socket and rotating the moving coil so as to apply a little reverse reaction. The valves actually used were a Cossor P2 in the first socket, a P1 as detector and a B4 in the last socket with 120 volts H.T., and 6 to 7½ volts negative bias. 50 volts will be found sufficient for the first two valves. In conclusion I should be pleased to know the results obtained by readers who construct this receiver.

The "Transatlantic Four"

SIR,—Just a line to let you know my remarkable results with the "Transatlantic Four," described by Mr. Percy W. Harris in MODERN WIRELESS, November, 1924. Using 30 ft. of covered wire in the bedroom, all B.B.C. stations are received at good 'phone strength, also London, Bournemouth and Birmingham on loud-speaker. On a good outdoor aerial 55 ft. by 40 ft. high, all stations except Manchester are at good loud-speaker strength. I might say that I had several friends in to hear my last set before I had given it a trial run, so that shows the confidence I had in a MODERN WIRELESS set of giving a good show. Wishing all Radio Press journals every success, not forgetting Mr. Percy Harris.—Yours truly,

J. GEDGE.

Aldershot, Hants.



Cosmos Components for Efficient Radio Sets

THE FOUNDATIONS

of your Radio Receiving Set are sound, efficient and reliable when the tuning circuit embodies the Components shown above.

COSMOS STRIP INDUCTANCE COILS are constructed on a new principle which results in Low Resistance, Low H.F. Resistance, Robust Constructions and Low Self-Capacity. With regard to the last feature, a report on an independent test conducted by "The Wireless Trader" (issue March 4th) reads as follows:—

"Our tests proved satisfactory, for the coil (tested on 377 metres) was found to have quite exceptionally low self-capacity. It was tested at the same time as a well-known and favourite type of plug-in coil, and the decrease in self-capacity was phenomenal, the other coil having approximately thirteen times the amount of self-capacity found in the 'Cosmos.'"

"COSMOS" STRIP PLUG-IN
INDUCTANCE COILS
are made in the following sizes:—

Coil No.	Inductance Microhenries.	Price s. d.
20	12.5	4/9
25	25	4/9
35	50	4/6
40	100	4/9
50	150	4/9
75	300	5/0
100	700	6/0
150	1000	6/6
175	1400	7/0
200	2500	7/6
300	5000	8/9
400	9000	9/9

POLAR PRECISION VARIABLE CONDENSERS
are made in the following capacities, all having the same outside dimensions.

Max. Capacity.	Price.
.001 mfd.	12/6 unmounted
.0005 mfd.	12/6 "
.0003 mfd.	12/6 "
Mounted 5/6 extra.	
SEPARATE VERNIER ATTACHMENT	
3/6	

THE POLAR PRECISION VARIABLE CONDENSER is a remarkably Compact, Robust, Dustproof Component with low minimum capacity, low losses, high insulation and a smooth movement. The last named feature is so effective that a Ver. i.e. plate is really unnecessary, but to provide for those amateurs who require exceptionally fine tuning, a separate Vernier attachment can be obtained. The Polar Precision Condenser is conveniently mounted by means of one hole in the panel.

YOU CAN OBTAIN THESE COMPONENTS FROM YOUR LOCAL WIRELESS DEALER, ALSO "COSMOS" RHEOSTATS, POTENTIOMETERS, FIXED CONDENSERS, GRID LEAKS, VARIOMETERS, REACTANCE COILS, AND ALL DETAIL ACCESSORIES.

METRO-VICK SUPPLIES LTD.,
4, Central Buildings, Westminster,
London, S.W.1

"HEARING
IS
BELIEVING"

In conjunction with a National Advertising Campaign, Wireless Retailers are giving specific demonstrations of "Cosmos" Universal Valve Sets. You, who are interested in Radio, will be delighted with the purity of reproduction obtained by this set, and will realise at once why it is called the "Musicians' Set." Hearing is believing.

In replying to advertisers, use Order Form enclosed.

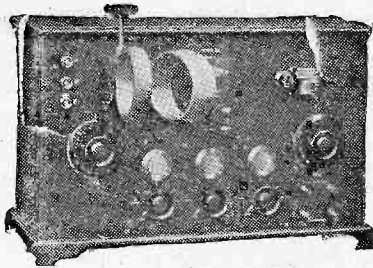

"Modern Wireless" Set

THE PURIFLEX SET.

Originally designed for "Modern Wireless" by Mr. Percy Harris. Uses a Crystal Reflex circuit with a two-stages of resistance coupled low-frequency amplification. Famed for its remarkable loud-speaker purity of reproduction. There is a complete absence of distortion with this Set.

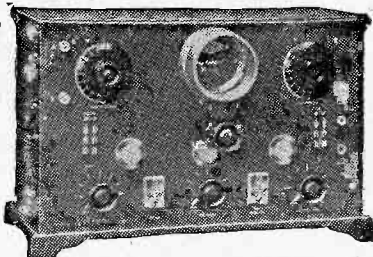

"Modern Wireless" Set.

THE ALL CONCERT-DE-LUXE.

A most handsome Receiver with all fittings supplied nickel-plated. Simple switches enable note magnifier valve being cut out if not required. Has a telephone range of 800 to 1,000 miles under normal conditions. All battery connections at rear, and plugs and jacks for telephones and loud-speaker fitted to panel.

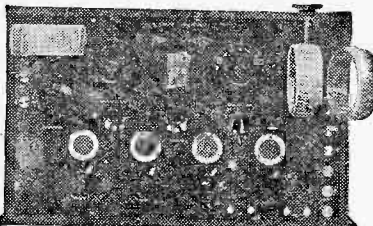

"Modern Wireless" Set.

THE FAMILY 4-VALVE SET.

An ideal family Receiver originally designed by Mr. Percy Harris. Uses the familiar tuned anode and reaction circuit. Large numbers of users report regular reception of American broadcasting on this Set. Can be used as a two, three, or four-valve Set at will.

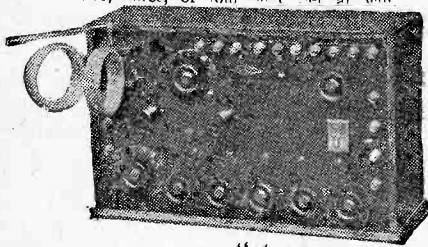

"Modern Wireless" Set.

THE TRANSATLANTIC V. RECEIVER. The first standard Set to use two stages of high-frequency amplification. A real long-distance Set. Will work particularly well on a simple little indoor aerial. Regular reception of American broadcasting and long-distance Continental stations at loud-speaker strength is an easy matter with this 5-valve Set.

C Our catalogue of components will save you pounds. 48 pages post free. **3d.**

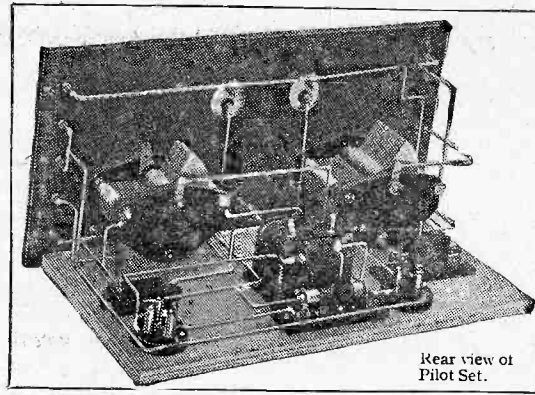

Rear view of Pilot Set.

Build a Pilot Set and save money

If you can use a pair of pliers to cut a length of wire—if you can screw a transformer to a ready drilled panel—if you can follow a simple wiring diagram, then you can build any of the splendid Sets illustrated on this page. From the 2-valve Resistoflex to the 6-valve Anglo-American designed by Mr. Percy Harris for "The Wireless Constructor," they represent all that is best and most original in British Radio design to-day.

Every one of these Pilot Receivers carries our full guarantee that if made according to our working instructions they will work perfectly. Indeed, we go further

than that—we have instituted a special Service Department to ferret out faults for you at a nominal cost, should the Set not work when you have made it up. Choose the best Set you can afford from the chart given below—if you have some of the parts already, we shall be pleased to supply you with the balance. If you have all the parts already, we shall be equally pleased to supply you with only the panel or the cabinet. If you cannot make up your mind which Set you will build, write for a copy of our 32-page Pilot Chart (post free 3d.), containing upwards of 30 illustrations of Pilot Receivers with the fullest details.

We will guarantee your results on a Pilot Set

If you buy your parts from us you are entitled to the free use of our Service Department. Any queries of a technical nature respecting the performance of any Peto-Scott Receiver are answered free of charge. If your Set does not work after you have built it send it back to us for our test and report. If due to any defect in the apparatus we will replace it without charge, and after having thoroughly tested out the Set on actual Broadcasting we will return it. On the other hand, should the defect be due to faulty wiring or a mistake on the part of the home constructor, we will be glad to rectify the error for a nominal sum and return it after it has given satisfactory service on actual Broadcasting. This Service Dept. is maintained exclusively to help our customers. We want every user of Peto-Scott apparatus to get the finest possible results.

Get the Pilot Chart To-day.

In addition to the Receivers described on this page, we supply also (in sets of parts for home construction or as finished instruments) many other types of Radio Receivers ranging from Crystal Sets to 6-valve Sets. Send 3d. to-day for a copy of our Pilot Chart, giving illustrations of 30 Sets, each with a complete list of parts required and their prices. This little Book will save you pounds by showing you how to build handsome long-distance Receivers at half shop cost. **3d.**

Name of Receiver.	No. of Valves.	Price of Panel drilled and engraved.	Kit of Components.	Oak Cabinet with baseboard.
		£ s. d.	£ s. d.	£ s. d.
All Concert-de-luxe	3	15 6	4 15 6	17 0
S.T. 100	2	7 0	4 14 0	1 10 0
Puriflex	3	15 6	4 2 0	17 0
All-Britain	3	15 6	4 16 1	17 0
4-Valve Family	4	17 0	5 16 8	17 0
Transatlantic V.	5	18 6	5 8 5	17 0
Anglo-American 6	6	1 8 6	9 9 9	3 1 6
Transatlantic 4	4	16 6	6 13 6	1 7 6
3-Valve Neutrodyne (Valve panel)	3	12 0	4 8 8	1 13 6
3-Valve Neutrodyne (Tuner panel)	—	11 6	4 2 3	to take both panels
T.A.T. 4-Valve Set	4	1 0 6	5 15 6	1 0 0
Harris Wavemeter	—	4 6	1 6 0	12 6
3-Valve Dual	3	17 0	5 5 0	15 6
Simplicity Receiver	3	12 0	3 16 0	10 6
7-Valve T.A.T. Receiver	7	1 17 6	7 18 0	1 12 6

SPECIAL NOTE: Where all components and panel are purchased together a Marconi Royalty of 12s. 6d. per valve-holder must be paid.

Peto-Scott Co., Ltd.,

Registered Office, Showroom and Mail Order Department, 77, City Rd., London, E.C.1

BRANCHES:

LONDON—62, High Holborn, W.C.1.
 WALTHAMSTOW—230, Wood St.
 LIVERPOOL—4, Manchester St.
 CARDIFF—94, Queen St.
 PLYMOUTH—4, Bank of England Place.

Regular Programmes from American Broadcasting Stations

Hours of transmission given in British Summer Time and in local time prevailing.

Telephony only.

Edited by Captain L. F. PLUGGE, B.Sc., F.R.Ae.S., F.R.Met.S. Copyright.

Until British Summer Time comes into force, note that one hour should be subtracted from time given.

WEEKDAYS.

Ref. No.	British Summer Time.	Local Time prevailing.	Name of Company owning station.	Call Sign and Wave-length.	Situation.	Nature of Transmission.	Approx. duration of Transmission.
A. 1	midnight.	6. 0 p.m.	Willard Storage Battery Co.	WTAM 390 m.	Cleveland, Ohio.	Dance Music, Concert; Orchestra.	1 hr.
A. 2	midnight.	6. 0 p.m.	Westinghouse Electric & Mfg. Co.	WBZ 337 m.	Springfield, Mass.	Dinner Concert.	—
A. 65	midnight.	6. 0 p.m.	American Tel. & Tel. Co.	WEAF 492 m.	New York.	Musical Programme.	5 hrs.
A. 61	midnight.	6. 0 p.m.	The Detroit News.	WWJ 352.7.	Detroit Mich.	Dinner Concert.	—
A. 3	12.15 a.m.	6.15 p.m.	L. Bamberger & Co.	WOR 495 m.	Newark, New Jersey.	Orchestra.	—
A. 4	12.15 a.m.	6.15 p.m.	Westinghouse Electric & Mfg. Co.	KDKA 326 m. & 68 m.	Pittsburgh, Pa.	Dinner Concert or Organ Recital.	—
A. 5	12.50 a.m.	5.50 p.m.	"Kansas City Star"	WDAF 411 m.	Kansas City, Mo.	Market, Weather Report, Time Signal, Road Report	10 min.
A. 6	1. 0 a.m.	6. 0 p.m.	"Kansas City Star"	WDAF 411 m.	Kansas City, Mo.	Talks, Story, Music.	1 hr.
A. 9	1. 0 a.m.	7. 0 p.m.	Goodyear Tyre & Rubber Co.	WEAR 390 m.	Cleveland, Ohio.	Concert (except Saturdays).	1 hr.
A. 7	1. 0 a.m.	7. 0 p.m.	Westinghouse Electric & Mfg. Co.	WBZ 337 m.	Springfield, Mass.	Market Report, Talks, Children's Stories.	15 min.
A. 8	1. 0 a.m.	6. 0 p.m.	Westinghouse Electric & Mfg. Co.	KYW 536 m.	Chicago, Ill.	News, Financial Markets.	16 min.
A. 13	1.15 a.m.	7.15 p.m.	Westinghouse Electric & Mfg. Co.	KDKA 326 m. & 68 m.	Pittsburgh, Pa.	News; Talks, Market Reports	15 min.
A. 11	1.15 a.m.	7.15 p.m.	Westinghouse Electric & Mfg. Co.	WBZ 337 m.	Springfield, Mass.	Talks followed by Concert or other Musical Programme.	—
A. 66	1.30 a.m.	6.30 p.m.	Chicago Tribune Broadcasting Co.	WGN 370 m.	Chicago, Ill.	Dinner Concert (Except Mondays).	30 min.
A. 10	1.30 a.m.	7.30 p.m.	Westinghouse Electric & Mfg. Co.	KDKA 326 m.	Pittsburgh, Pa.	Children's Period. (not on 68 m.)	—
A. 12	1.30 a.m.	6.30 p.m.	Woodmen of the World.	WOAW 526 m.	Omaha, Nebraska.	Concert or Orchestra.	—
A. 62	1.30 a.m.	7.30 p.m.	State College, Washington	KFAE	Pullman, Washington.	Concert.	—
A. 14	1.35 a.m.	6.35 p.m.	Westinghouse Electric & Mfg. Co.	KYW 536 m.	Chicago, Ill.	Children's Period.	25 min.
A. 15	1.45 a.m.	7.45 p.m.	General Electric Co.	WGY 380 m.	Schenectady, New York.	Musical Programme and/or talks (except Wed. and Sat.).	—
A. 16	2. 0 a.m.	7. 0 p.m.	Westinghouse Electric & Mfg. Co.	KYW 536 m.	Chicago, Ill.	Talks, Dinner Concerts, Musical Programmes. (Mondays excepted).	2½ hrs.
A. 17	2. 0 a.m.	7. 0 p.m.	Sears-Roebuck & Co.	WLS 345 m.	Chicago, Ill.	Children's Period (Mondays excepted)	20 min.
A. 63	2.15 a.m.	8.15 p.m.	The Radio Lighthouse.	WEMC 286 m.	Berrion Springs, Michigan.	Concert.	1½ hrs.
A. 18	2.30 a.m.	8.30 p.m.	Westinghouse Electric & Mfg. Co.	KDKA 326 m. & 68 m.	Pittsburgh, Pa.	Concert and Musical Programme.	—

WEEKDAYS—continued.

Ref. No.	British Summer Time.	Local Time prevailing.	Name of Company owning Station.	Call Sign and Wave-length.	Situation.	Nature of Transmission.	Approx. duration of Transmission.
A. 19	2.30 a.m.	7.30 p.m.	"Fort Worth Star Telegram."	WBAP 476 m.	Fort Worth, Texas.	Musical Programme (except Saturday).	1 hr.
A. 72	3.0 a.m.	8.0 p.m.	Sears-Roebuck & Co.	WLS 345 m.	Chicago, Ill.	Concert (except Mondays and Thursdays).	2½ hrs.
A. 67	3.0 a.m.	8.0 p.m.	Chicago Tribune Broadcasting Co.	WGN 370 m.	Chicago, Ill.	Vocal & Instrumental Music (except Mondays).	1 hr.
A. 20	3.0 a.m.	8.0 p.m.	"Kansas City Star."	WDAF 411 m.	Kansas City, Mo.	Musical Programme.	1½ hrs.
A. 70	3.0 a.m.	8.0 p.m.	St. Louis Post-Dispatch.	KSD 545 m.	St. Louis.	Concert (except Wednesdays & Fridays).	2 hrs.
A. 64	3.0 a.m.	9.0 p.m.	The Shepard Stores	WNAC 280.3 m.	Boston, Mass.	Concert.	2 hrs.
A. 21	3.55 a.m.	9.55 p.m.	John Wanamaker	WOO 509 m.	Philadelphia, Pa.	U.S. Naval Observatory Time Signal followed by U.S. Weather forecast.	—
A. 22	3.55 a.m.	9.55 p.m.	Westinghouse Electric & Mfg. Co.	KDKA 326 m. & 68 m.	Pittsburg, Pa.	Do. do.	—
A. 23	3.55 a.m.	9.55 p.m.	Westinghouse Electric & Mfg. Co.	WBZ 337 m.	Springfield, Mass.	Do. do.	—
A. 73	4.0 a.m.	7.0 p.m.	KFI Radio Central Super Station.	KFI 467 m.	Los Angeles, Cal.	Musical Programme.	4 hrs.
A. 24	4.0 a.m.	9.0 p.m.	Woodmen of the World.	WOAW 526 m.	Omaha, Nebraska.	Concert (except Wednesdays).	—
A. 25	4.0 a.m.	10.0 p.m.	Westinghouse Electric & Mfg. Co.	WBZ 337 m.	Springfield, Mass.	Musical Programme (except Tuesdays).	1 hr. or 2 hrs.
A. 26	4.15 a.m.	7.15 p.m.	"Morning Oregonian."	KGW 492 m.	Portland, Oregon.	Markets, Weather Report, News, Police Reports (Sats. excepted).	—
A. 27	4.30 a.m.	9.30 p.m.	"Fort Worth Star Telegram."	WBAP 476 m.	Fort Worth, Texas.	Musical Programme (except Saturday).	1½ hrs.
A. 68	5.0 a.m.	10.0 p.m.	Chicago Tribune Broadcasting Co.	WGN 370 m.	Chicago, Ill.	Dance Orchestra & popular songs (except Mondays).	1 hr.
A. 28	5.0 a.m.	10.0 p.m.	Westinghouse Electric & Mfg. Co.	KYW 536 m.	Chicago, Ill.	Musical Entertainment (except Mondays). Sometimes begins 9.30 p.m.	1 hr. or 2 hrs.
A. 29	6.45 a.m.	11.45 p.m.	"Kansas City Star."	WDAF 411 m.	Kansas City, Mo.	Musical Entertainment.	1½ hrs.

SUNDAYS.

Ref. No.	British Summer Time.	Local Time prevailing.	Name of Company owning Station.	Call Sign and Wave-length.	Situation.	Nature of Transmission.	Approx. duration of Transmission.
A. 30	12.30 a.m.	6.15 p.m.	Westinghouse Electric & Mfg. Co.	KDKA 326 m. & 68 m.	Pittsburg, Pa.	Dinner Concert.	—
A. 77	1.0 a.m.	7.0 p.m.	Sears-Roebuck & Co.	WLS 345 m.	Chicago, Ill.	Orchestra.	—
A. 31	1.0 a.m.	6.0 p.m.	Woodmen of the World.	WOAW 526 m.	Omaha, Nebraska.	Bible Study Hour.	1 hr.
A. 79	1.20 a.m.	7.20 p.m.	Chesapeake and Potomac Telephone Co.	WCAP 469 m.	Washington, D.C.	Musical Programme and Organ Recital.	3 hrs.
A. 66	1.20 a.m.	7.20 p.m.	American Tel. & Tel. Co.	WEAF 492 m.	New York.	Musical Programme.	3 hrs.
A. 32	1.30 a.m.	7.30 p.m.	Strawbridge and Clothier.	WFI 395 m.	Philadelphia, Pa.	Church Service.	—
A. 33	1.30 a.m.	7.30 p.m.	General Electric Co.	WGY 380 m.	Schenectady, New York.	Church Service.	—

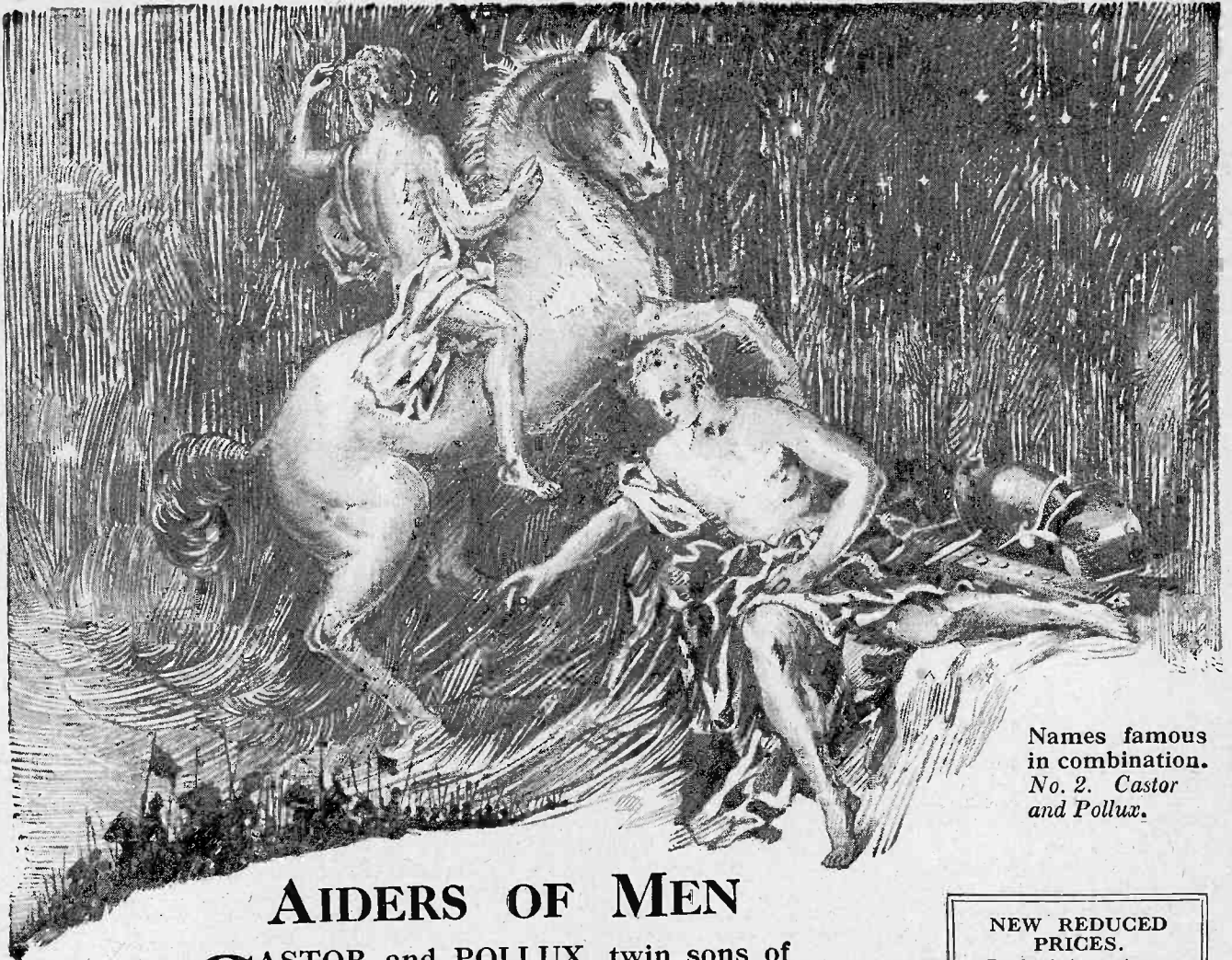

Names famous in combination.
No. 2. Castor and Pollux.

AIDERS OF MEN

CASTOR and POLLUX, twin sons of Zeus, were regarded as aiders of men, patrons of travellers and guardians of hospitality.

A more familiar conjunction of names, because they belong to our everyday life, is that of MARCONI and OSRAM—the names of the two famous organisations which have combined to produce wireless valves of unparalleled excellence—"The Valve in the Purple Box."

Read the 40-page wireless book, The Book of MOV. Free from your dealer or The M.O. Valve Co., Ltd., Hammersmith, London, W.6.

NEW REDUCED PRICES.

For 2-volt Accumulators.		
Purpose.	Type.	Price.
†G.P.	D.E.R.	18/-
†L.S.	D.E.G.	22/6
For 4-volt Accumulators.		
G.P.	R.	11/-
G.P.	*D.E.3.	21/-
L.S.	D.E.4.	26/-
For 6 volt. Accumulators.		
G.P.	R.5.V.	11/-
L.S.	D.E.5.	30/-
L.S.	*D.E.5b.	30/-
L.S.	L.S.5.	60/-

†G.P. = General Purpose.
†L.S. = Specially suitable for low frequency amplification for Loud Speakers.
*Can be used with Dry Batteries.
For Resistance - capacity Amplification.

MARCONI VALVES

MADE AT THE OSRAM LAMP WORKS

Sold by Wireless & Electrical Dealers, Stores, etc.

ANNOUNCEMENT OF THE M.O. VALVE CO. LTD

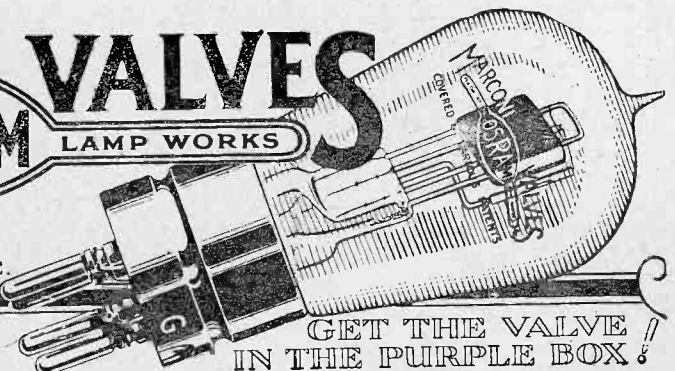

GET THE VALVE IN THE PURPLE BOX!

The Radio Mail

For sensitiveness
use
**Wuncell
Valves**

Published periodically in the interest of Valve Users

A new type of Dull Emitter Experts declare new Wuncell Dull Emitter likely to revolutionise Valve design

TO produce a Dull Emitter Valve which operates with a glow that is almost invisible in daylight is a feat that has just been accomplished by the London firm of A. C. Cossor Ltd. This new Valve—called the Wuncell because it requires only one cell to operate it—is certainly the nearest approach to the ideal of a "cold valve" that we have yet seen. Viewed under working conditions the filament could just be seen glowing in daylight, while in a dark room it could readily be likened to the embers of a dying match.

Asked to give some approximate idea of the actual temperature, a representative of the firm stated that, according to pyrometer tests, the reading was 800 degrees as against the 2,000 degrees, required by Bright Emitters and even some types of Dull Emitters. For our benefit actual tests were made between the amount of heat (or light) generated by a Wuncell and other types of Valves. The differences were most marked, and demonstrated to the lay mind in a very striking manner that such a low filament temperature must mean a vastly increased life for the Valve.

The British Valve still the best

But it was on actual Broadcasting tests that this new Wuncell showed that, so far as this country is concerned, we have nothing to fear from Continental Valve manufacturers. For the purposes of demonstration a good four-Valve set was used. For the first Valve—which acted as a high-frequency amplifier—a Wuncell type W.2 was used, while for the last stage one of the new Wuncell Loud Speaker Valves was used as a power amplifier. The other two Valves were the standard W.1 Wuncells.

Connected to a fairly good aerial in North London, 2LO had to be considerably de-tuned even for three Valves in order to prevent "blasting" from the Loud Speaker, while with the fourth valve in operation every B.B.C. main station, with the exception of Cardiff, was brought in with incredible volume and exceptional purity. Cardiff

—owing to our close proximity to 2LO—could not be tuned in. The following Continental stations were also received at good Loud Speaker strength: Hilversum (a Dutch broadcasting station with call sign HDO), Bremen on 330 metres, Zurich, Radio Iberica of Madrid, and a further Continental station which could not be identified owing to "fading" but which corresponded in wave-length to Vienna.

Wuncells just as sensitive as Bright Emitter Valves

The result of these tests certainly demonstrated that the new Wuncell Valves are not one whit less sensitive than standard Bright Emitter Valves. Another remarkable feature of these Wuncell Valves was their complete freedom from microphonic noises. It has hitherto always been an inherent disadvantage of other dull emitters that even footsteps in the room or other slight vibrations are communicated to the Valve to cause ringing noises in the headphones or Loud Speaker. All the usual tests, such as tapping the table on which the receiver was placed, adjustments of the rheostats, etc., failed to produce the slightest suggestion of a microphonic noise.

We understand that the reason for this improvement is to be found in the special Wuncell method of mounting the filament. Instead of being supported between two electrodes, sprung apart to counteract expansion and contraction, its filament is arched (following standard Cossor practice) and supported at the centre by a third electrode. No doubt, too, the grid—cleverly designed and very rigid—is a contributory factor to this result.

Use Wuncells along with Bright Emitters in the same Set

We were most impressed, not only by the very neat appearance of the Wuncell, but with the vast amount of forethought and research work that must obviously have been put into its construction. For instance, because it was realised by the designers that

many multi-valve users would like to try out one Wuncell in conjunction with their ordinary Valves, a special base was designed. This base carries a resistance in series with the filament to permit the valve being used with either a 4- or 6-volt accumulator. Normally, of course, the Wuncell functions at rather less than 2 volts. This excellent idea gives any amateur a chance of trying out one of these new Dull Emitters and comparing its behaviour with the Bright Emitters he may be using. At any later date—by the use of a small screw—the resistance can be short-circuited and the Wuncell used at its correct current of 2 volts. It is worth while noting, too, that all Wuncell Valves are being supplied with the new black low-capacity base in which air only is used at the dielectric between the leads to the four valve legs.

Experts that have witnessed demonstrations of Wuncell valves have expressed their satisfaction at the production of a Dull Emitter which can compare most favourably with the best Bright Emitters. It has always been felt that hitherto a sacrifice of at least 20 per cent. in volume has been the price that must be paid to obtain the conveniences offered by Dull Emitters.

Valves to be in sealed boxes

One well-known manufacturer definitely decides to issue all future Valves in sealed cartons only

A move of the utmost importance has been made by A. C. Cossor Ltd.—the well-known British Valve manufacturers. They have decided that, in order to protect the public and to ensure their Valves being used in absolutely new condition, they are now sealing every Valve in its carton at the Works. Asked how it would be possible for the shopkeeper to be certain that he was selling a sound Cossor Valve, a member of the firm explained to a representative of the *Radio Mail* that this was a matter which had certainly presented some difficulties. Various methods had been carefully tried out, including sealing the legs of the Valves and other devices, but none had proved so satisfactory in practice as the method they were now adopting. This consists of wrapping the Valves in a very generous covering of cotton wool, after having first brought two copper wires from the filament legs to two studs on the end of the box. When a customer wants a Cossor Valve, these two brass contacts are placed in series with an electric flash-lamp battery and a bulb. If the filament should happen to be damaged, the circuit will not be complete and the lamp will not light. This test can be easily carried out without breaking the seal of the box by means of a very ingenious showcard, which we understand Cossor's are supplying free of charge to all Wireless dealers.

A prominent manufacturer of Broadcast Instruments emphatically endorsed this new idea. He agreed that it was a wise move that had been long awaited. The public, he declared, welcomed any method of purchasing usable accessories under a seal. In his opinion the Wireless dealer—while not shirking responsibility—considered that the manufacturer ought to take steps to see that his (the manufacturer's) responsibility ended only when the article reached the actual user.

How long should Valves last?

Many keen wireless amateurs get over twelve months' service

How long a Valve lasts depends very largely on how it is used. Some men can make their suits last very much longer than others—a little care and attention now and again will prevent creases forming and the material from losing its freshness. The same applies to Valves. For instance, how many amateurs know that the use of filament switches in a Receiving Set—although a great convenience—shortens the lives of the Valves very considerably. Rheostats should be used for the purpose of turning current on and off; to throw the full load on at the turn of a switch is to cause a sudden expansion of the wire used in the filament, and to switch off suddenly is to cause a sudden contraction. No Valves built can withstand such strains indefinitely.

Treat your Valves properly and you'll find they'll last very much longer. For instance, Mr. G. H. Haseman, of 9 Gailiard Road, writes as follows:—

"I think it is only right to testify to the excellence of Cossor Valves, more particularly as far as I am concerned the P.1. On December 1, 1923, I purchased two of these Valves and they have been going strong ever since, and are functioning well now."

They have been in use on an average of 2 1/2 hours per day from date of purchase, which brings present life up to nearly 1,000 hours. How long they will last I cannot say—perhaps you can estimate. However, I shall certainly repeat a selection of Cossor P.1."

While Mr. J. Harris, of 13 Stepeny Bank, Newcastle-on-Tyne, thinks that sixteen months' regular service for one Cossor Valve is something of a record. Writing on January 27, 1925, he says:—

"In September of 1923 I purchased a P.1 Cossor Valve, and wish to state that it has given me excellent service until to-day. The Valve in question has never missed the Savoy Bands, nor Official News of the B.B.C. Total life of Valve, sixteen months. Perhaps there are others who can beat this record, but I, as an old user of Cossors, am perfectly satisfied."

Even this record would seem to be eclipsed by a Cossor P.1 which has been doing yeoman service every day for a period of 1,700 working hours on a One-Valve Reflex Set. The owner, Mr. Harold Cooper, of 8 Cotherton Road, London, S.W. 2, expresses his satisfaction in these terms:—

"I should like to mention that I have used a Cossor No. V. 9132 in use since last September, and averaging at four hours per day (very moderate average for afternoons and evenings) it has given over 1,700 working hours, and is still going strong, and therefore bears out conclusively all you claim in your advertisement; my circuit is One-Valve Crystal 'Rellex.'"

Cossor Valves

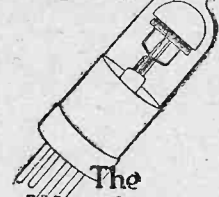

The Valves that give your Set that long distance feeling!

Have you got down to the short waves yet?

Get ready for the new Broadcasting Stations operating on 100 metres or less

There's lots of enjoyment to be obtained from short-wave reception. If you can read Morse, you should certainly alter your set so that you can get down to 80 metres and under. Any evening will find scores of British amateurs corresponding with their friends across the seas. The most extraordinary thing about these short waves is their tremendous power of penetration. Using but very little power, amateurs can send messages immense distances. Incidentally the tuning of short waves means

the use only of high-grade components and suitable Valves. How far American amateurs can send on short waves is a matter of conjecture—it is sufficient to say that signals have been received in this country without aerial or earth. In this connection, Mr. J. Gordon Ritchie, the well-known Glasgow experimenter, writes as follows:—

"10th December, 1924. "Some time ago I wrote you concerning the excellent reception of American broadcasting obtained with two of your P.1 Valves. They have since demonstrated their capabilities in another way."

I am now using a Reinartz-type receiver on the very short waves of 80 metres and under, consisting of detector and one low-frequency, and during the past fortnight have logged 105 American amateurs, of which twenty were heard on one night without either aerial or earth. Either of my two 'Cossors,' now almost two years old, are the only Valves I have got to oscillate below about 60 metres. Considering the constant use and incidental 'knocking about' to which these Valves have been subjected, I think this speaks highly for your products, and I am looking forward to a further period of their usefulness."

SUNDAYS—(continued.)

Ref. No.	British Summer Time.	Local Time prevailing.	Name of Company owning station.	Call Sign and Wave-length.	Situation.	Nature of Transmission.	Approx. duration of Transmission.
A. 34	1.30 a.m.	7.45 p.m.	Westinghouse Electric & Mfg. Co.	KDKA 326 m. & 68 m.	Pittsburg, Pa.	Church Service	—
A. 37	1.30 a.m.	7.30 p.m.	Westinghouse Electric & Mfg. Co.	WBZ 337 m.	Springfield, Mass.	Concert or Music, etc.	—
A. 76	1.30 a.m.	7.30 p.m.	Federal Telephone Manufacturing Co.	WGR 319 m.	Hotel Statler, Buffalo, N.Y.	Church Service.	—
A. 35	1.45 a.m.	7.45 p.m.	John Wanamaker.	WOO 509 m.	Philadelphia, Pa.	Church Service (occasionally at 11.45 p.m. instead).	—
A. 36	2.0 a.m.	7.0 p.m.	Westinghouse Electric & Mfg. Co.	KYW 536 m.	Chicago, Ill.	Service & Musical programme.	—
A. 67	2.15 a.m.	8.15 p.m.	The Radio Light-house.	WEMC 286 m.	Berrion Springs, Michigan.	Church Service.	—
A. 38	3.0 a.m.	6.0 p.m.	"Morning Oregonian."	KGW 492 m.	Portland, Oregon.	Church Service.	—
A. 39	3.0 a.m.	9.0 p.m.	General Electric Co.	WGY 380 m.	Schenectady, New York.	Hotel Orchestra, relayed.	—
A. 40	3.30 a.m.	9.30 p.m.	Westinghouse Electric & Mfg. Co.	WBZ 337 m.	Springfield, Mass.	Concert or Music, etc.	—
A. 41	4.0 a.m.	7.0 p.m.	"Morning Oregonian."	KGW 492 m.	Portland, Oregon.	Hotel Orchestra, relayed.	—
A. 78	4.0 a.m.	7.0 p.m.	KFI Radio Central Super-Station.	KFI 467 m.	Los Angeles, Cal.	Musical programme.	4 hrs.
A. 42	4.0 a.m.	9.0 p.m.	Woodmen of the World.	WOAW 526 m.	Omaha, Nebraska.	Church Service.	—
A. 75	4.0 a.m.	9.0 p.m.	Chicago Tribune Broadcasting Co.	WGN 370 m.	Chicago.	Concert.	1 hr.
A. 43	8.0 a.m.	11.0 p.m.	"Fort Worth Star Telegram."	WBAP 476 m.	"Fort Worth, Texas."	Dance Orchestra.	1 hr.

SPECIAL DAYS.

Ref. No.	British Summer Time	Local Time prevailing.	Name of Company owning station.	Call Sign and Wave-length.	Situation.	Nature of Transmission & day of week on which occurring.	Approx. duration of Transmission.
A. 44	12.30 a.m.	6.30 p.m.	General Electric Co.	WGY 380 m.	Schenectady, New York.	Tues. & Thurs.—Hotel Music relayed.	—
A. 45	12.30 a.m.	6.30 p.m.	Strawbridge and Clothier.	WFI 395 m.	Philadelphia, Pa.	Wed.—Children's story.	—
A. 74	1.0 a.m.	7.0 p.m.	Chesapeake and Potomac Telephone Co.	WCAP 469 m.	Washington, D.C.	Mon. & Sat.—Hotel Concert Orchestra, followed by Children's period at 7.0 p.m.	4 hrs.
A. 46	1.0 a.m.	6.0 p.m.	Woodmen of the World.	WOAW 526 m.	Omaha, Nebraska.	Mon. & Tues.—Lecture.	—
A. 47	1.30 a.m.	7.30 p.m.	John Wanamaker.	WOO 509 m.	Philadelphia, Pa.	Thurs. & Fri.—Children's Hour.	—
A. 48	2.0 a.m.	8.0 p.m.	Strawbridge and Clothier.	WFI 395 m.	Philadelphia, Pa.	Sat.—Concert.	3½ hrs.
A. 49	2.0 a.m.	8.0 p.m.	L. Bamberger & Co.	WOR 495 m.	Newark, New Jersey.	Mon., Wed., Fri.—Organ or Orchestral Concerts, Talks.	—
A. 50	2.0 a.m.	8.0 p.m.	Willard Storage Battery Co.	WTAM 390 m.	Cleveland, Ohio.	Thurs.—Boy Scout Programme, followed by Concert at 8.30 p.m.	2½ hrs.
A. 51	3.0 a.m.	9.0 p.m.	Willard Storage Battery Co.	WTAM 390 m. or 361 m.	Cleveland, Ohio.	Tues. and Sat.—Concert.	2½ hrs.
						Mon., Wed., Sat.—Musical Programme, Talks.	3 or 4 hrs.
						Mon. & Wed.—Concert.	2 hrs.
						Sat.—Dance Programme.	3 hrs.

SPECIAL DAYS—(Continued.)

Ref. No.	British Summer Time.	Local Time prevailing.	Name of Company owning station.	Call Sign and Wave-length.	Situation.	Nature of Transmission and day of week on which occurring.	Approx. duration of Transmission.
A. 71	3. 0 a.m.	9. 0 p.m.	Federal Telephone Manufacturing Corporation.	WGR 319 m.	Hotel Statler, Buffalo, N. Y.	Concert & Supper Music (Mondays, Wednesdays and Fridays).	2½ hrs.
A. 52	3.30 a.m.	9.30 p.m.	General Electric Co.	WGY 380 m.	Schenectady, New York.	Sat.—Dance Music.	—
A. 53	4. 0 a.m.	7. 0 p.m.	"Morning Oregonian."	KGW 492 m.	Portland, Oregon.	Mon. & Wed.—Concert. Tues. & Fri.—Talk.	—
A. 54	4.30 a.m.	10.30 p.m.	Willard Storage Battery Co.	WTAM 390 m.	Cleveland, Ohio	Mon.—Dance Programme.	2½ hrs.
A. 55	4.30 a.m.	10.30 p.m.	General Electric Co.	WGY 380 m.	Schenectady, New York.	Fri.—Musical programme.	—
A. 56	5.30 a.m.	11.30 p.m.	General Electric Co.	WGY 380 m.	Schenectady, New York.	Tues. & Thurs. Organ Recital.	—
A. 57	5.30 a.m.	10.30 p.m.	Woodmen of the World.	WOAW 526 m.	Omaha, Nebraska.	Tues. or Thurs.—Entertainment. Fri.—Relayed Orchestra.	—
A. 58	5.30 a.m.	11.30 p.m.	Westinghouse Electric & Mfg. Co.	WBZ 337 m.	Springfield, Mass.	Tues.—Organ Recital.	—
A. 59	6.15 a.m.	11.15 p.m.	Woodmen of the World.	WOAW 526 m.	Omaha, Nebraska.	Sat.—Entertainment.	—
A. 59a	7. 0 a.m.	10. 0 p.m.	"Morning Oregonian."	KGW 492 m.	Portland, Oregon.	Mon., Tues. and Sat.—Dance Music.	—
A. 60	7. 0 a.m.	midnight	Westinghouse Electric & Mfg. Co.	KYW 536 m.	Chicago, Ill.	Sat.—Hotel Band Relayed.	2 hrs.

Results with a T.A.T. Circuit

SIR,—I fear I have been very remiss in not letting you know before the results I obtained with 2 H.F. T.A.T. (as described by Mr. John Scott-Taggart in the November issue) on my experimental board early in November at Buxton.

Aerial used was a Vertex, about 10 feet above a chimney stack, and 40 feet from the ground.

Earth, double.—One 7 ft. to C!max buried tube; one 20 ft. to main water pipe.

Results.—On good nights, using one L.F. only, every main B.B.C. station good loud-speaker strength; also the following relays:—Stoke, Sheffield, Nottingham, Leeds, Bradford, Hull, Liverpool.

With two stages L.F. comfortable loud-speaker strength from Plymouth (230 miles), provided that Hull was not transmitting, and from Dundee (215 miles).

I found no trouble in separating Madrid from Newcastle; but found that Hamburg and Madrid heterodyned each other.

Amongst the German stations Eberswalde and Nuremburg were nearly always loud-speaker strength.

On bad nights, Bournemouth, London and Cardiff were difficult to pick up, but Aberdeen (260 miles)

always came in at great strength.

I have been using the original circuit published, *i.e.*, with a 250 choke coil, and no grid bias, except on the L.F. stages.

The great beauty of the circuit is that it enables one to get the

distant stations without distortion on the loud-speaker.

I also use reaction on the tuned anode coil.

Otherwise, I have worked along the same lines as you have suggested in your more recent articles on the T.A.T.

Wishing you success to all your various publications.—Yours truly,

M. G. FERGUSON.
Pampstead, N.W. 3.

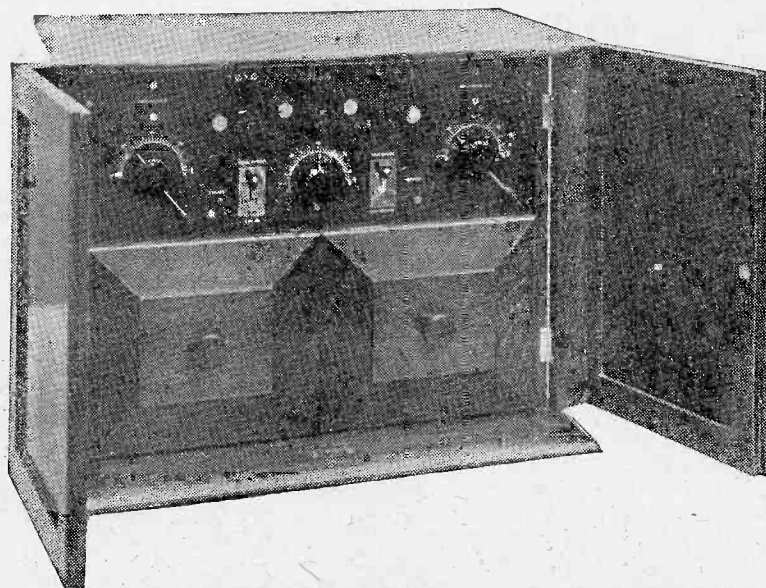

The four-valve receiver presented by H.M. the King and Viscount Lascelles to the stable lads at Egerton House,



THIS
IS THE
SIGN
OF THE
MOST
EFFICIENT
COIL

THE REASON WHY Gambrell Coils surpass all others in efficiency is owing to their unique patented construction which enables a series of coils to be produced having extremely small H.F. resistance and almost negligible self capacity.

Gambrell Coils are known by letters instead of numbers, such as 35, 50, 75, etc., which refer to the number of turns in an ordinary coil, for the simple reason that giving the number of turns in Gambrell Coils gives no true comparison with other makes. (See table below.)

Very full information about the above and other features which result in Gambrell Coils being more efficient than ordinary coils will be found in the pamphlet "Efficiency" Inductances which will be sent to you on application.

If your Retailer has not Gambrell Coils in stock
—he can quickly obtain them to your order.

Members of the Trade who have not yet received our literature are particularly requested to write for same.

GAMBRELL BROS. LTD.
76, Victoria St., London, S.W.1

Works: Merton Road, Southfields, S.W.18.

*Phones: VICTORIA 9938

PUTNEY 3641-2

Insist on having the Coil contained in the Red Carton bearing the above sign.

You will then be certain of obtaining the coil which gives the best results.

GAMBRELL COILS						
No. of Turns on ordinary Coils.	On 100 feet P.M.G. Aerial with '00065 Microfarad Maximum Condenser					Price
		Series		Parallel		
—	a/2	70	105	130	210	5/9
25	a	110	165	200	315	5/9
35	A	175	260	325	510	5/9
50	B	275	415	495	825	6/-
75	C	380	530	690	1150	6/9
100	—	—	—	—	—	—
—	D	530	750	975	1625	8/-
150	—	—	—	—	—	—
200	E	880	1200	1600	2700	9/6
300	F	—	—	2550	4200	10/3
500	G	—	—	3650	6200	12/-
600	—	—	—	—	—	—
—	H	—	—	5,800	10,000	14/-
750	—	—	—	—	—	—
1,000	I	—	—	8,900	14,500	16/-
1,500	J	—	—	14,000	24,000	19/-

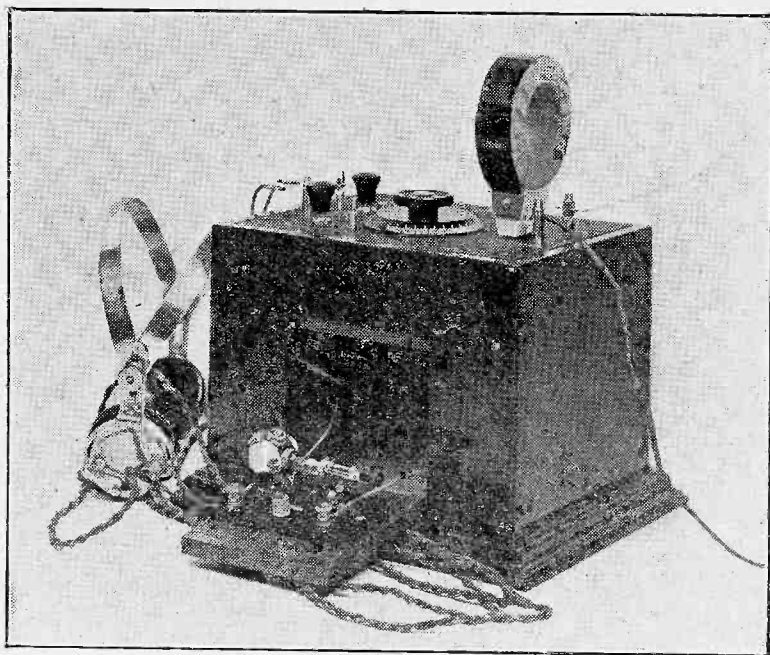

The small door on which the detector is mounted allows it to be shut away from the dust.

THE crystal set about to be described is so arranged that comparative tests of different crystals and plug-in coils may be easily made. But while having these advantages, it does not, as many experimental crystal sets do, look large and complicated with many detectors, switches and terminals on it. On the contrary, it has a very neat and compact appearance, and may very well take the place of the ordinary drawing-room set, and have the aforementioned advantages in flexibility.

General Description

The detector, which is of the multiple crystal type, is completely protected from dust by being shut right into the cabinet by means of the small door in the front of the cabinet. The tuner for the lower range of broadcasting wavelengths consists of a highly efficient type of tapped basket coil wound on a permanent former and tuned by means of a variable condenser. It is possible to use a loading coil in series with this for the high-powered station; the plug for such a coil is seen to the right of the panel. By means of the lower switch on the left-hand side it is possible to short this plug when it is not in use, or to short the fixed basket coil so that the condenser may be shunted across the plug-in coil alone, thus making it possible roughly to test the comparative wavelength band and efficiency of various commercial coils and also home-made ones.

The top switch is for selecting the most suitable tapping on the basket coil.

Components

Before going on with the construction of this receiver, it may be as well to give a list of the component parts required. The coil former is not obtainable commercially, and must therefore be made

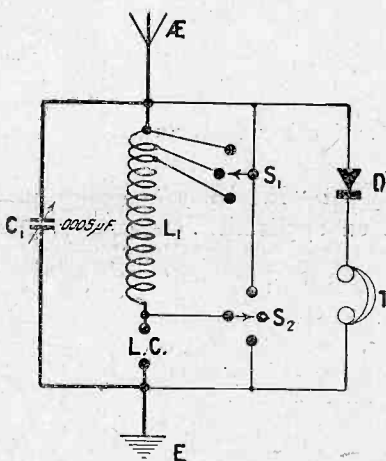

Fig. 1.—A theoretical diagram of the circuit used.

at home; but this will not be found very difficult if the instructions given further on are followed. The components required, other than the material for the former, which will probably be found in the junk box, are as given in the following list:—

A Crystal Set for Comparative Tests

By
A. S. CLARK

List of Parts Required

- 1 Ebonite panel, 6 in. by 8 in. by 1/4 in. (Peter Curtis).
- 1 .0005 mfd. variable condenser (Jackson Bros. square-law).
- 1 Loading coil plug (Woodhall flush mounting).
- 2 Stud switches with 3 contacts and 2 stops each (Bowyer-Lowe).
- 4 Terminals (Arthur Butler spring type).
- 1 Decko dial indicator.
- 1 Multi Crystal detector (Service Radio Co.)
- 1 Packet Radio Press panel transfers.
- 1/2 lb. No. 20 d.c.c. copper wire.
- Quantity square wire, flex, etc.
- 1 Cabinet for horizontal panel with door, dimensions given in Fig. 4. (W. H. Agar).

Use of other Components

The particular make of component is given for those who desire to follow the actual receiver in every detail. But any other similar components of good make will do just as well. There will probably be found plenty of room for them on the panel.

The Construction

The first thing to do in the construction is to make the former for the coil. The materials required for this are: some odd pieces of ebonite, one 1/4 B.A. nut and bolt, and two or three bone knitting needles. These latter should be about 1/4 in. to 3/16 in. in diameter and long enough so that seven pieces 2 1/4 in. long may be cut from them. First cut the seven pieces of knitting needle; a hack-saw will do the job quite well. Now cut out a seven-sided piece of 1/4 in. ebonite to the dimensions given in Fig. 3; the length of the sides is, best found by trial. Each corner is flattened off a little with a file and a hole drilled at each one about 1/4 in. deep and a little smaller than

This neat little crystal receiver includes a new method of detector mounting, and it allows interesting experiments to be conducted, whilst always remaining ready for broadcast reception.

the diameter of the knitting needles. Having completed this piece of ebonite and drilled a 4 B.A. clearance hole in its centre, we are in a position to fix the spokes into position. This is done by first tapering them a little with a file for about a $\frac{1}{4}$ in. of their length and, after smearing the ends with a little glue, hammering them into the holes at the corners of the centre piece of ebonite.

Winding the Coil

The glue on the spokes must first be left to harden properly before winding is commenced, which is carried out in the following manner. Take one end of the d.c.c. wire and give it a twist round one of the spokes, leaving a length of about 6 in. for connecting purposes. Now wind on 45 turns of wire. It is not possible with this thick wire to make a very neat coil, but the efficiency of a coil wound with it is

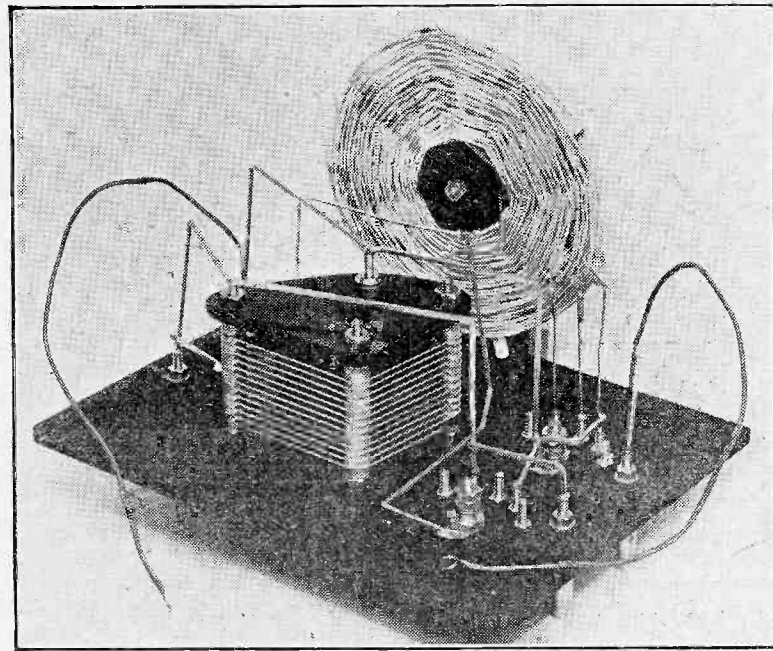

The underside of the panel, clearly illustrating the basket coil and its tappings.

worth the slight loss in neatness. After winding on 45 turns give the wire a twist round the same spoke it was started on, and after making a loop about 6 ins. long, again twist it round this spoke and continue to wind in the same direction as before. After another ten turns have been added, a further tap is taken in the same manner as the first. All the taps and the two ends should be brought out at the same side of the coil. Place another ten turns on, and then finish the coil off by giving the

wire a twist round the spoke and threading it through the coil at about six turns from the outside. If it does not seem as if all the turns will go on, it is because the coil is not being wound tightly enough. Fig. 3 makes the coil construction clear.

The Coil Holder

A piece of ebonite to hold the coil to the panel is cut to the dimensions given in Fig. 6, and the coil is clamped to it as shown, a small ebonite washer of $\frac{1}{4}$ in. thickness being interposed between the coil and its holder. Two holes for 4 or 6 B.A. screws must be tapped in the bottom of this piece of ebonite where shown, or if no taps are available it is possible to force the screws into holes a little too small for them. The tappings should be placed so that they are to the right side of the coil when it is looked at with its support at the back; this will make the connections from the tappings short and neat. Before connections are made to the coil, the loops must be cut in the middle and the wire on both the resulting ends bared right up to the coil; now twist the ends together once or twice. Cut one of them off short to about $\frac{1}{2}$ in. and solder it to the other, which is used for making the actual joint.

Drilling the Panel

We must next drill the panel to the dimensions given in Fig. 2. With the particular type of coil plug and switches used, a template is supplied on their containing boxes,

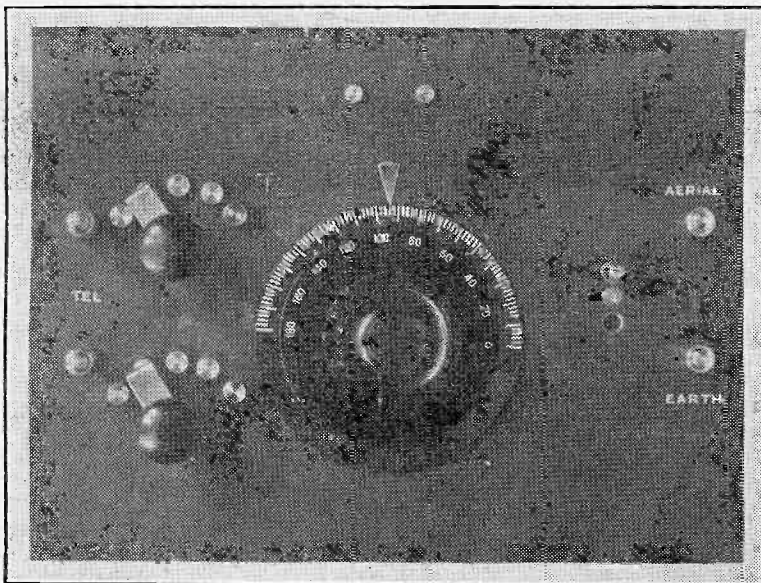

The simple layout is seen in this photograph. Note that the telephone terminals are on the left.

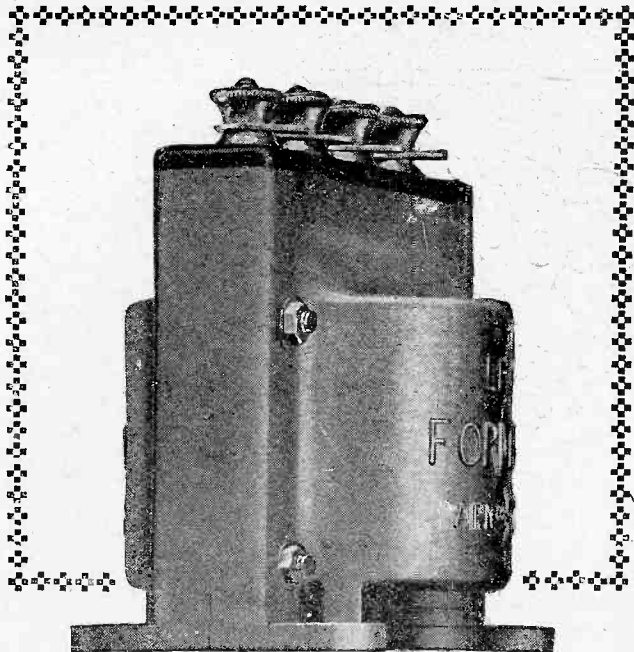

The FAMOUS FORMO L.F. TRANSFORMER

—a gilt-edged security

The building of a receiver is a great adventure. Who knows but what you will build to create some new record, that you will surpass even the envied loud-speaker reproductions of your friends who use the Famous Formo L.F. Transformer?

That should be your endeavour and your adventure—to seek, not how much raucous power you can persuade from your receiver, but to build differently and with a new endeavour. Incorporate the Famous Formo L.F. Transformer into your set and you will discover that its performance contains a quality which previously you have mourned as something which could not be your reward.

It is this performance, consistent, reliable and of pleasing excellence, that comes by your choice of this Famous Formo Component. It is far from an adventure. Those experimenters—who have learnt wisdom at the cost of bitter experience—build the Famous Formo L.F. Transformer into their sets consistently.

They know only too well that the search for good speech and music reproduction ends abruptly—it begins and ends with the Famous Formo L.F. Transformer.

PRICE 18/-

The reflection of our confidence in the Famous Formo Components is epitomised in this our guarantee: that these are guaranteed unconditionally to perform satisfactorily, to be highly efficient and to give results unexcelled.

Ask your dealer also for the Formolenset and the Formo Portable Aerial. Be sure you get the Famous Formo Components—they are gilt-edged securities.

THE FORMO COMPANY

(ARTHUR PREEN & Co., LTD.)

Contractors to the Admiralty, War Office, India Office, Air Ministry, and Post Office.

Chief Office and Works:

CROWN WORKS, CRICKLEWOOD LANE, N.W.2.

Resident Representatives:

Scotland: Mr. Miller, 22, York Place, Edinburgh.

Manchester: Mr. J. B. Levee, 23, Hartley Street, Levenshulme.

Birmingham: Mr. H. E. Crocker, 134, Reservoir Road, Erdington.

Barclays 918

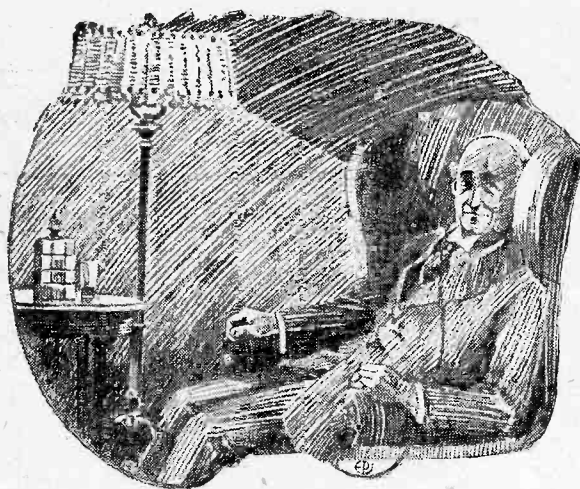

I may be lazy!

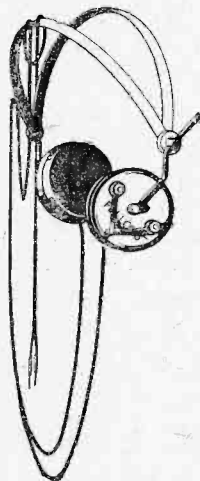

—but I'm not selfish. I don't insist on having the Loud Speaker going full blast when I want to listen-in at my ease and the rest of the family want to be quiet; for even my family want to be quiet sometimes. Of course I must admit I'm not really quite as unselfish as appears at first sight. Listening-in on Fellows Headphones is no handicap to enjoyment, but actually makes a pleasant change from the blare of a Loud Speaker.

The 'phones fit so well that discomfort is a minus quantity. They are also easily adjusted to suit everybody's head, and never get tangled in your hair and won't in your wife's hair either.

The quality of reproduction is perfect. It is attended to by experts who know as much about sound and its reproduction as they do about electricity.

And all for 16/6. I think you'll admit Quality Apparatus at Low Cost.

Muelo Fellows

YEATES LTD., 20, Store Street, Tottenham Court Road, W.C.1.

Well-equipped Sales and Demonstration Offices for Fellows Wireless Products. Wholesale and Retail.

The LIGHTWEIGHT HEADPHONES.

Highly finished.

Duralumin non-rusting Head-bands. Weight only 6 ounces with cord.

Resistance 4,000 Ohms.

Price 16/6

FELLOWS WIRELESS

ADVT. OF THE FELLOWS MAGNET CO., LTD., PARK ROYAL, LONDON, N.W.10.

E.P.S. 127

In replying to advertisers, use Order Form enclosed.

Reduced Prices of B.T.H. Radio Apparatus

In consequence of the reductions in the prices of B.T.H. Headphones and B.T.H. Radio Valves, coupled with the increased demand for Radiola Receivers, the following revised schedule of prices is current as from February 17th.

Apparatus	Complete with			Old Price	New Price
	Headphones	Valves	Dry Batteries		
Radiola "Bijou" Crystal Receiver	1 set 4000 ohm.	£ s. d. 3 5 0	£ s. d. 215 0 0
Radiola "Model A" Crystal Receiver	1 set 4000 ohm.	4 15 0	4 5 0
Loading Device , 1,600 Metres, for above	8 6	8 0
Radiola I. Valve-Crystal Receiver	1 set 4000 ohm.	1 B5	H.T.	11 0 0	10 0 0
Loading Coils 1,600 Metres, for above	17 0	16 0
Radiola II. 2-Valve Receiver	1 set 4000 ohm.	2 B5	H.T. and L.T.	21 0 0	19 0 0
Radiola III. 3-Valve Cabinet Receiver , with enclosed Loud Speaker	1 set 4000 ohm.	3 B5	H.T. and L.T.	50 0 0	49 0 0
Radiola VI. 6-Valve Cabinet Receiver , with enclosed Loud Speaker	1 set 4000 ohm.	{ 4 B5 2 B6 }	H.T. and L.T.	137 0 0	135 0 0
Radiola Portable 3-Valve Receiver , Leather finish.....	1 set 4000 ohm.	3 B5	H.T. and L.T.	28 0 0	27 0 0
Ditto Mahogany finish	" "	" "	" "	30 10 0	29 10 0
Power Amplifier, 2-Valve	2B+or 2B6	12 10 0	12 0 0
Unit Amplifier, 1-Valve	2 15 0	2 15 0
Portable Loud Speaker & Amplifier , Leather finish	2 B6	H.T. and L.T.	24 0 0	23 10 0
Ditto Mahogany finish	"	" "	26 0 0	25 10 0
Headphones 4,000 ohms.	1 5 0	1 0 0
Headphones 120 ohms.	1 2 6	1 0 0
R Valve	12 6	11 0
B3 Valve	1 1 0	18 0
B4 Valve	1 15 0	1 10 0
B5 Valve	1 5 0	1 1 0
B6 Valve	1 15 0	1 10 0
B7 Valve	1 17 6	1 12 0

The new price of the Radiola, II 2-valve Receiver includes Loading Coils (1600 metres) for the High Powered Station.



Advertisement of The British Thomson-Houston Co. Ltd.

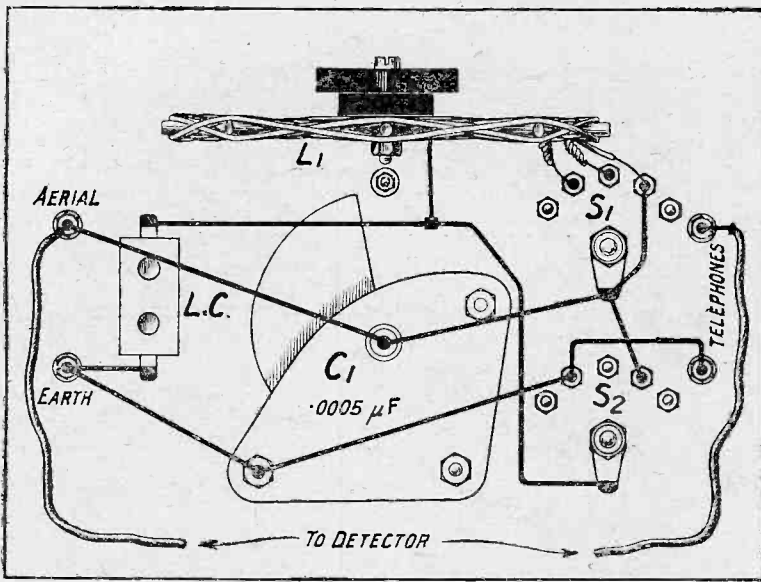

Fig. 5.—When wiring up the receiver this diagram should be followed carefully.

between the two crystal detector terminals. This cup will screw on in place of the catwhisker and the tightening nut which holds it, and is only fixed to the base as a secure place for keeping it.

Longwave Reception

When it is desired to receive Chelmsford or the spark time signals sent out from the Eiffel Tower, a plug-in coil is inserted

condenser the local station is tuned in. The lower the reading at which it comes in loudest, the higher the wavelength to which the particular coil will tune.

Test Report

In testing this receiver, its

greatest advantage was found to be the ease with which it was possible to change over from the local station, which is 2LO, to Chelmsford. With a 150 or 200 coil in the loading coil socket 5XX was received almost as loud as 2LO in S.W. London. The strength of the London station was remarkably loud for a crystal set, it being possible to just hear the programme at any point in a fair size room out of a small loud speaker.

When using an aperiodic aerial coil the signal strength was not reduced. The best tuning position for the local station was with the tapping switch on the middle stud and with the condenser at about 80 degrees, thus indicating that the coil would tune easily over the whole B.B.C. wavelengths. Ship stations and Eiffel Tower time signals were received at good strength, and it was very easy to compare different coils as already indicated. Listening after the B.B.C. stations had closed down on Sunday, 15th March, a station of French origin was heard loud enough to distinguish the speech. Indications point to this station being Petit Parisian.

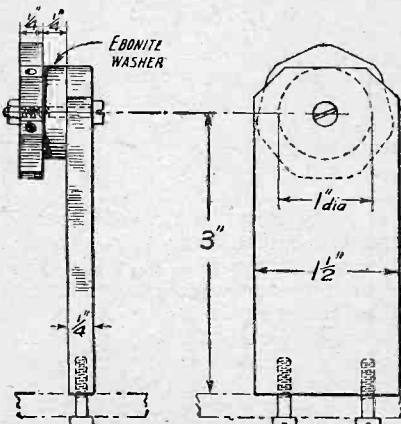
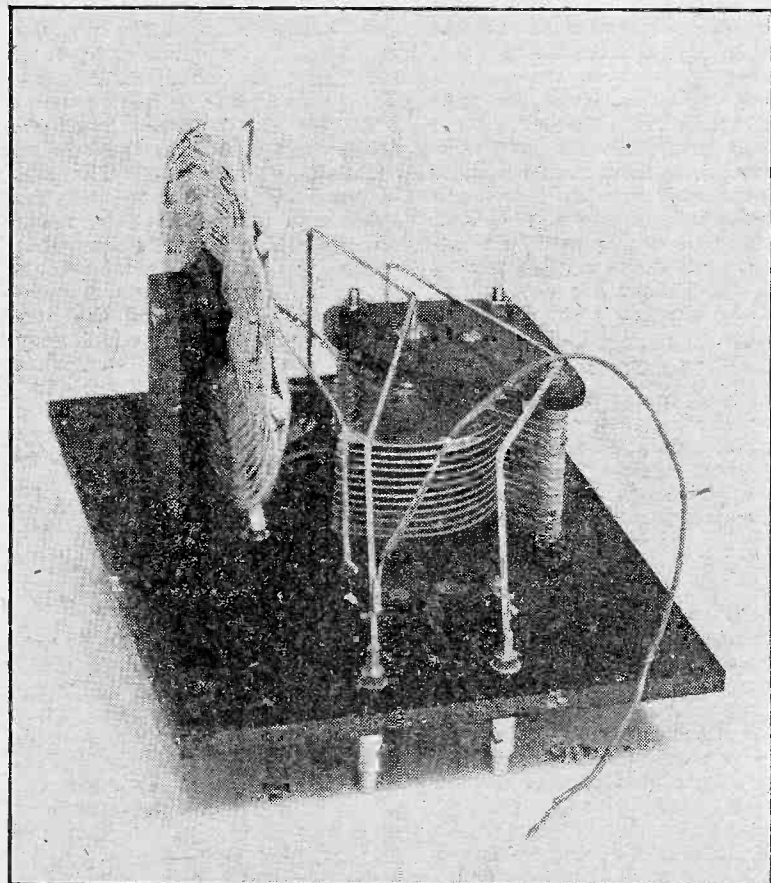

Fig. 6.—Dimensions of the piece of ebonite used for fixing the coil to the panel.

in the loading coil socket to the right end of the panel, and the lower switch placed on the middle stud. The top switch should be placed on the left-hand stud.

If it is desired to find the comparative efficiency of a number of plug-in coils on either the short or long wavelengths, the lower switch is placed on its left-hand stud, and tuning done by means of the condenser. It is possible to get a rough idea of the comparative maximum or minimum to which two plug-in coils will tune by observing at which adjustment of the variable



Another view of the wiring, showing how the tuning coil is mounted.



Radio Press News

A NEW PUBLICATION.

OF the new Radio Press books and other publications just in the press, probably the one with the widest appeal is a particularly original and helpful little volume by R. W. Hallows, M.A., Staff Editor, whose articles in our journals are so well known for their wide scope and thorough grasp of detail. This new book is entitled "Wireless Faults and How to Find Them" (R.P. Series, No. 24, price 1s. 6d., post free 1s. 8d.), and the very title should make it plain that this is a book which no wireless man can afford to miss, for the subject is one in which we all take an extreme interest at certain times, when we welcome any aid, however small.

The assistance given by this most interesting little book, however, is far from small, and it is difficult to see how even the most stubborn of concealed faults can evade for long anyone who has read it and who carries out the ingenious methods of trouble tracing which the author has devised, so searching are the tests which he describes.

The Contents

The book opens with a chapter giving the necessary details for the construction of an extremely cheap and simple but effective little appliance which is used in conjunction with a pair of telephones for the greater part of the testing of the set and its constituent parts. The author then proceeds to deal thoroughly with the testing of all those of the principal components of a set which are commonly responsible for faults, such as condensers, fixed and variable, transformers, coils, detectors, and so on, passing from components actually forming a part of the set to such accessories as valves, batteries and aerial and earth.

These sections of the book are to be regarded as preliminary to the chapters on actual set testing, and a very useful and time-saving

method has been adopted here. The author gives (and explains fully) a complete series of tests for the set under consideration, which are designed to narrow down gradually the possible area of the trouble until it is finally tracked down in a particular circuit, say the anode circuit of a low-frequency amplifying valve, and then finally in a particular component, perhaps the L.F. transformer. The reader then refers back to the section on the testing of L.F. transformers, and proceeds to find out exactly what is wrong with his defective specimen.

A complete separate chapter is provided to explain the testing of crystal sets, and another for single-valve sets, while general tests for the common types of multi-valve sets form the subject of another section. The last chapter deals in full detail with the subject of fault-tracing in reflex circuits, which demands somewhat special treatment, as most readers are no doubt aware. The symptoms which they display and the particular types of faults which may occur are naturally somewhat different from those of "straight" circuits, but the whole matter is treated most lucidly, and anyone who has had the misfortune to incorporate unknowingly a dud component in a reflex set will be able to set about its location with entire confidence with the aid of this book.

A Valuable Feature

A specially valuable and time-saving feature will be found in the summaries appended to each chapter, which take the form of clearly arranged tables with headings for "Symptoms," "Possible Causes," etc., so that the whole provides a brief summary upon a single page of the preceding chapter. One can therefore use it as an aid to memory and run through the whole series of systematic tests for any given set very

rapidly, having previously read the whole chapter. The arrangement, of course, is rather like that of the analysis tables used by chemists.

The book has been so written and arranged that it can be understood and used with perfect ease by even the absolute beginner, who will particularly appreciate the very full and complete way it has been illustrated. Every difficult point, and indeed practically every point which could be made clearer by means of a diagram, is illustrated, so that there is an illustration of some sort on almost every page.

(Date of publication, April 16th.)

"Six Simple Sets," by Stanley G. Rattee, M.I.R.E., Staff Editor (R.P. Series, No. 21, price, 1s. 6d., post free 1s. 8d.), has now been on sale for some weeks, and has exceeded even the expectations of popularity expressed at the time of its publication. Sales are proving extremely rapid, and form a gratifying testimony to the faith which our readers place in the soundness of the designs of Radio Press authors in general, and of those of Mr. Rattee in particular.

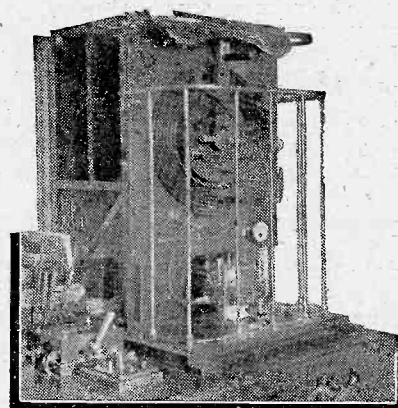

The spark transmitting apparatus on the s.s. "Maloja."



Type 620.
 Similar to type 610,
 but for vertical panel
 mounting. Fitted
 with screw terminals.
 0.001-0.009 mfd. 3/6
 0.01 mfd. 4/-
 0.011-0.015 mfd. 4/6

Type 610.
 A new Mica Condenser, suitable
 for all purposes. Fitted with
 screw terminals and detachable
 grid-leak clips.
 0.001-0.009 mfd. .. 3/6
 0.01 mfd. .. 4/-
 0.011-0.015 mfd. .. 4/6

Why Mica ?

These are two new and improved Dubilier Mica Condensers suitable for use in all circuits. They represent a considerable advance in convenience for general purposes over the Types 600 and 600a, and are known as Types 610 and 620 respectively.

* * *

And now, why Mica ? Why not paper, or treated rubber, or some other and cheaper composition ? The capacity of a condenser depends on three things : the size of the plates, their distance apart, and that property of the di-electric that is measured in terms of " Specific Inductive Capacity " (S.I.C.) The greater the S.I.C. of a di-electric the smaller quantity is required to produce a given capacity ; this also enables the whole condenser to be smaller, more compact, and less liable to inaccuracies and variations.

Now, Mica has a high S.I.C. It also has great " di-electric strength "—i.e., it will not break down electrically even under very high voltages. It is, therefore, easily the most reliable and constant di-electric there is, particularly for capacities of less than about 1 mfd.

Although they are a little dearer, it always pays to

Specify Dubilier.



Advt. of the Dubilier Condenser Co., Ltd., Ducon Works, Victoria Rd., North Acton, London, W.3.

Telephone : Chiswick 2241-2-3.

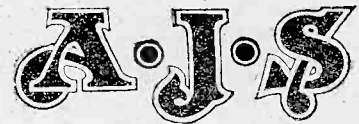

"THE HALL MARK OF RADIO PERFECTION."

You should see
the new **A.J.S.** models
if only to observe the
great improvement
now achieved in
Receiver Construction

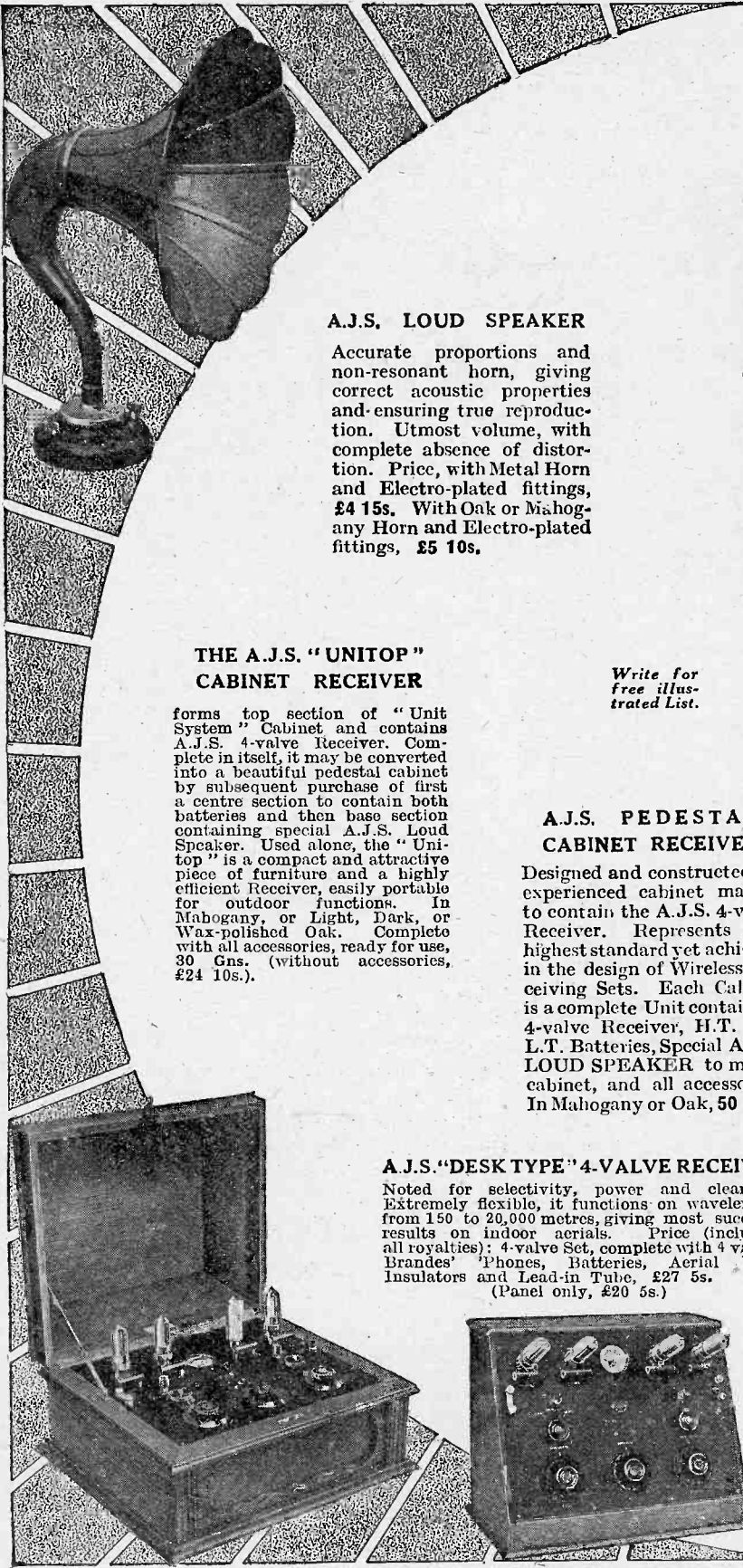

A.J.S. LOUD SPEAKER

Accurate proportions and non-resonant horn, giving correct acoustic properties and ensuring true reproduction. Utmost volume, with complete absence of distortion. Price, with Metal Horn and Electro-plated fittings, **£4 15s.** With Oak or Mahogany Horn and Electro-plated fittings, **£5 10s.**

THE A.J.S. "UNITOP" CABINET RECEIVER

forms top section of "Unit System" Cabinet and contains A.J.S. 4-valve Receiver. Complete in itself, it may be converted into a beautiful pedestal cabinet by subsequent purchase of first a centre section to contain both batteries and then base section containing special A.J.S. Loud Speaker. Used alone, the "Unitop" is a compact and attractive piece of furniture and a highly efficient Receiver, easily portable for outdoor functions. In Mahogany, or Light, Dark, or Wax-polished Oak. Complete with all accessories, ready for use, **30 Gns.** (without accessories, **£24 10s.**)

Write for free illustrated List.

A.J.S. PEDESTAL CABINET RECEIVER

Designed and constructed by experienced cabinet makers to contain the A.J.S. 4-valve Receiver. Represents the highest standard yet achieved in the design of Wireless Receiving Sets. Each Cabinet is a complete Unit containing 4-valve Receiver, H.T. and L.T. Batteries, Special A.J.S. LOUD SPEAKER to match cabinet, and all accessories. In Mahogany or Oak, **50 Gns.**

A.J.S. "DESK TYPE" 4-VALVE RECEIVER

Noted for selectivity, power and clearness. Extremely flexible, it functions on wavelengths from 150 to 20,000 metres, giving most successful results on indoor aeriols. Price (including all royalties): 4-valve Set, complete with 4 valves, Brandes' Phones, Batteries, Aerial Wire, Insulators and Lead-in Tube, **£27 5s.** (Panel only, **£20 5s.**)

A. J. STEVENS & Co. (1914) Ltd.
Wireless Branch, Wolverhampton

Telephone: 1550 Wireless Call Sign: 5 RI.
Telegrams: "Reception, Wolverhampton."

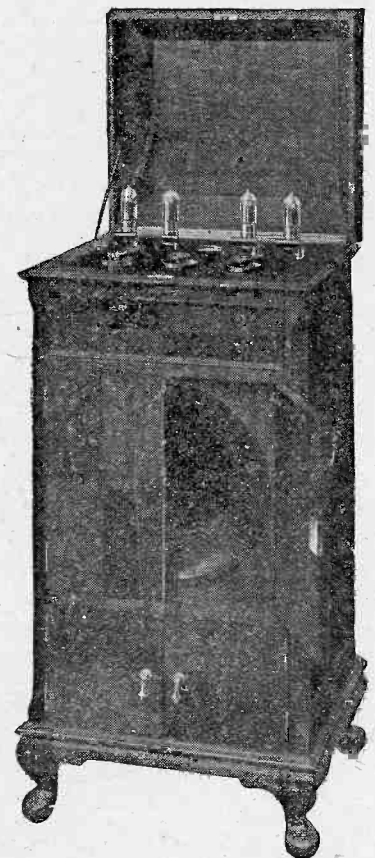

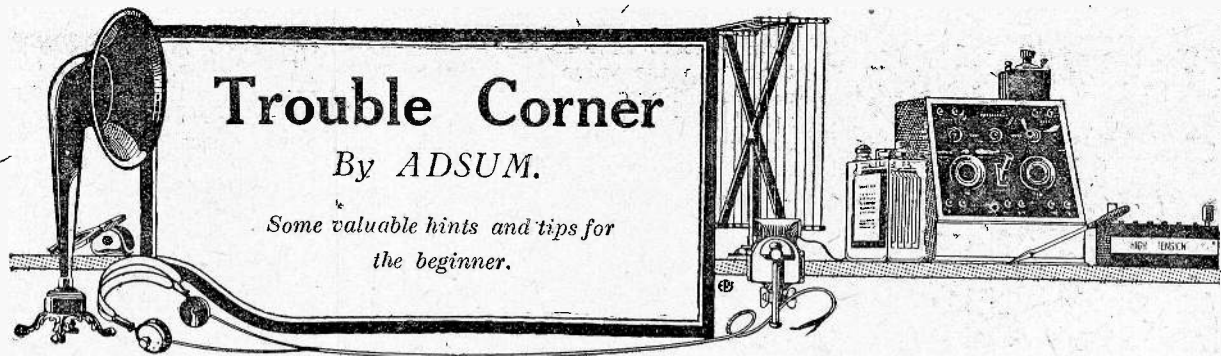

An Amusing Case

RECENTLY I came across a fault of quite a novel kind. A friend, who is more or less a beginner at wireless, had made a two-valve set consisting of a rectifier followed by a transformer-coupled note magnifier. Instead of the ordinary four-pin valve he had used a pair of the anti-capacity or "test tube" type. He brought the set round to me one evening complaining that it would not work. The symptoms were that no signals of any sort or kind could be brought in. As an examination of the wiring disclosed nothing amiss, the set was attached to the aerial for a practical test. It was obvious that something was seriously wrong, for not a sound could be heard when a buzzer wavemeter was placed quite close to the A.T.I. and tuned through a band of wavelengths which must have been covered by the particular coil in use. When a milliammeter was inserted into the high-tension circuit it disclosed such a terrific plate current that the set was hastily switched off. A reading of some 20 milliamperes was obviously excessive for two valves!

The Result

On looking at the valves themselves I saw at once what had happened. They had been placed wrongly in their clip holders, with the result that the plates were in contact with the grid connections and *vice versa*. The result of doing this is to produce the amazing circuit shown in Fig. 1, and it was hardly surprising to find that the set refused to work. When the valves were turned round it functioned excellently. It is quite easy to make a mistake when placing anti-capacity valves in their holders if one is careless about it, since they will go in just as easily either way. In fact, I must confess that I have done it myself in an absent-minded moment on more than one occasion. In these valves the little metal cap which forms the plate contact is

coloured red or green to distinguish it from the grid contact on the opposite side. My beginner friend took it that the special colouring indicated that it belonged to the grid. But there is another way of distinguishing the contacts from one another which is useful, partly because it makes a strong appeal to the eye and partly because this indication is always there, though the red or green colouring of the plate contact may be rubbed off in course of long service. If you look at Fig. 2 you will see that the "pip" of the valve is upon the same side as the grid contact. This seems the rule in test tube valves, and it is a handy thing to

the set was put together, or with the connections, I suspected the valves. I therefore resorted to the substitution method, replacing first of all each of the D.E.Q.'s with another valve of the same type. This produced no result, but when I changed the first D.E.V. for another signals came in as they should have done. The valve was put aside to be tested later. When it was tried out subsequently in another holder it was found to be functioning, though not very well. What had happened was that the plate contact had become rather dirty and when this was brightened up with a small piece of the finest emery cloth the valve was restored to its

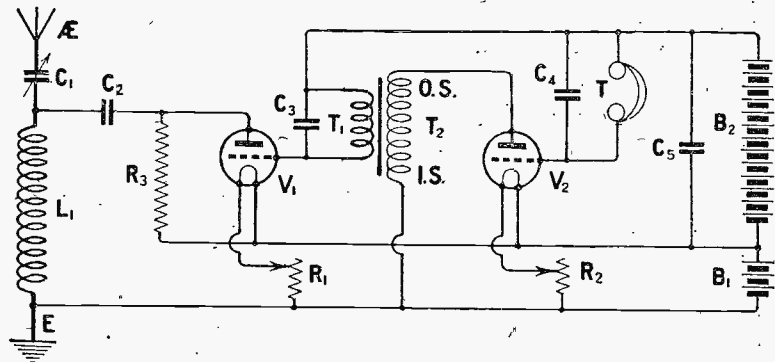

Fig. 1.—A strange circuit resulting from incorrect insertion in their clips of two "test tube" valves.

remember. If you happen to change a valve always look at it to see that its "pip" is pointing in the same direction as those of the others.

A "Test Tube" Valve Tip

Even if they are correctly placed in their holders anti-capacity valves may occasionally be a little troublesome. The other day, when trying out a newly-made four-valve set fitted with two D.E.V.'s and two D.E.Q.'s, I was unable to get any signals at all at the first attempt. As I was quite sure that there was nothing wrong with the components, all of which had been tested before

normal excellence. Those who use anti-capacity valves should bear in mind that a bad contact between either a plate or a grid boss and its clip is much more likely to occur than it is between the corresponding pins and legs of a valve of the ordinary type in its holder.

Poor Contact

The clips do not exert at any time a particularly firm pressure upon the little caps of test tube valves, so that a very thin film of dirt or grease may be sufficient to throw them out of action, or, at any event, to give curious results. It is as well to give both plate and

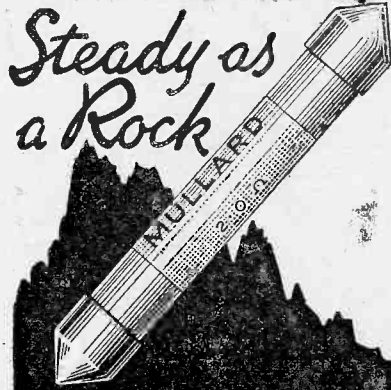

MULLARD EVER-REST GRID LEAKS

are silent in use and constant in value. Absolutely unaffected by climatic conditions. Made in two types:

- (1) For grid leaks with suitable condensers and
- (2) For Anode circuits of resistance amplifiers.

EVER REST Grid B
.3 to 5 megohms, 2/6 each.
EVER REST Anode B
.02 to 0.1 megohms, 2/6 each.

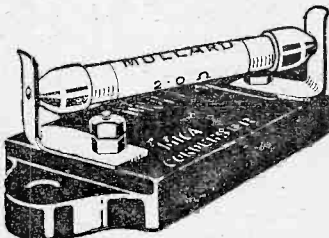

Complete with high standard and guaranteed exact capacity fixed condenser.

Grid B with .0003 mfd. Condenser Type M.A., 5/-

Mullard Condensers only
Type M.A.
.0002—.004 mfd., 2/6 each.
Type M.B.
.005—.01 mfd., 3/- each.



Adv. (Mullard), Nightingale Lane, Balham, S.W. 12.

grid clips a good bend inwards from time to time so as to make them grip the valve as firmly as possible. Further, each of the metal caps should receive an occasional rub over with fine emery and the same treatment should be given to the contact faces of the clips so as to keep them bright and clean. Contacts can also be kept fairly clean if the following simple method is used pretty frequently. Leaving the valve in its holder, grasp it with the forefinger and thumb of one hand and turn it slightly from side to side half-a-dozen times. In this way the caps are rubbed against the faces of the clips with the result that both surfaces are cleaned.

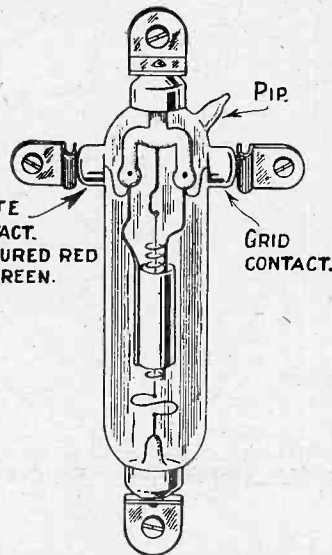

Fig. 2.—The "pip" is usually on the same side as the grid contact.

Fluxes and Leaks

Does a deposit of greasy flux upon the surface of an ebonite panel spoil its insulating properties? I have always felt quite sure that it does, in view of practical experience of various troubles which occurred with panels in a messy state and disappeared when the deposit of flux upon them was removed. However, if two terminals are placed quite close together and flux is deliberately run on to the panel between them, the "megger" fails to disclose any leakage. I have tried this several times and have always obtained a reading of "infinity." In last month's MODERN WIRELESS a confirmation of my belief that messy panels are leaky was given from two different sources. The Test Department states that one of the main sources of trouble in defective sets is to be found in a layer of flux upon the

panel, due to bad soldering. Again, Mr. A. D. Cowper, in writing on the "Super Negadyne," states that the least trace of flux left upon the panel between valve sockets is sufficient to make it impossible to produce a "gridleak howl." Those who find that their sets are unduly noisy when no signals are coming in, that tuning is flat, and that there is difficulty in producing oscillation, should bear these facts in mind.

Preventing Flux Deposit

The trouble is very likely due not to any defect in the ebonite but to the presence of a film of flux between contacts, especially valve legs, on its under side. I have known any number of cases of flatness, deadness and noisiness which were cured at once by washing the panels over carefully with absolute alcohol. But by far the best method is to prevent the occurrence of leakage and not to have to find a cure for it. My own tip when soldering is simply this. When the panel is ready for its connections to be made I press a piece of blotting paper about 2 in. square on to the shank of each terminal, pushing it down until it lies on the ebonite. Valve legs are treated in the same way. If the smallest amount of flux is then used any splutterings are caught by the blotting paper, which is removed by tearing it away when the job is done. This simple tip enables one to turn out a set with panels that are absolutely clean, and if it is used there need be no fear provided that the ebonite is of good quality, that there will be high resistance leaks sufficient to cause a variety of unpleasant results.

Crystal Troubles

Quite often I have brought round for examination a crystal set which is either not working at all or is doing extremely badly. Sometimes the fault is one of the usual ones, such as a broken lead, a faulty coil or a bad contact with the moving plates of the variable condenser. But in the great majority of cases none of the components are at fault. If ever you come across a crystal set which has shown a gradual decline in signal strength until finally signals are either very weak indeed or absent altogether, look to the crystal itself in the first instance. Very often the trouble is due to the way in which it has been mounted in its cup. The average galena crystal is a fairly delicate thing which will not stand much heat without losing its sensitiveness. Many amateurs

ruin their crystals by embedding them in Wood's metal which has been made too hot, or, worse still, in common solder. In such cases a crystal sometimes loses its sensitiveness at once, and the set never works satisfactorily. But sometimes again the application of excessive heat produces not an immediate loss of sensitiveness but rather a progressive and fairly rapid decline. Solder should never be used for mounting any type of crystal, and personally I would never recommend even Wood's metal with its much lower melting point for the use of a beginner. If you use the latter, heat it up in the cup until it runs and then allow it to cool until it has almost set before embedding the crystal in it. Some amalgam pastes, again, are not satisfactory, since they are made with mercury which has an action, not only upon the crystal itself, but also upon the brass of the cup in which it rests, producing as a rule a slow falling off in signal strength.

handle a crystal—use tweezers for picking it up; never allow its surface to become damp or dusty, and wash it over from time to time with a small camel hair brush dipped in absolute alcohol.

Switching Troubles

The temptation to fit switches to the wireless set is a strong one, for they enable so many circuit changes to be made in the easiest way in the world. It is, however, a temptation which should be resisted, upon the high-frequency side of the set at any rate. Not long ago I built a receiving set with two stages of high-frequency amplification which gave excellent results when it was first used. It was as sensitive, as selective, and as stable as one could wish for. Later I succumbed to the temptation and fitted very small switches, unfortunately rather a risky thing to do in a receiver of this type. The switches used were the tune-standby and the series-parallel seen in

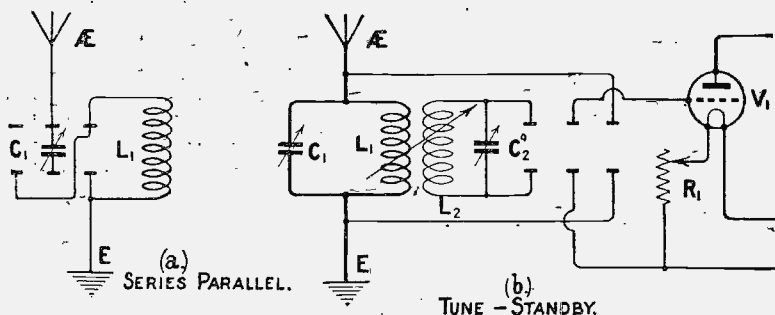

Fig. 3.—Two common forms of switching. A series-parallel arrangement is shown at (a) and tune-standby at (b).

To my mind by far the best way of mounting a crystal in the ordinary cup is to provide four fixing screws.

A Good Method

This can easily be done by drilling and tapping equally spaced 6 B.A. holes round the side of the cup. With three screws only it is often difficult to get an awkwardly shaped piece of crystal securely fixed, but with four even the most irregularly shaped piece can generally be gripped firmly without much difficulty. It is a good tip, too, before inserting the crystal into its holder to wrap it in tin foil which should be moulded to its contours by pressure with the fingers. When the crystal has been fixed the tin foil covering its upper surface can be removed with a penknife. It should hardly be necessary to mention that the crystal *must* be kept clean, but one finds so many cases of bad reception caused by dirty crystals that a reminder is perhaps as well. Never

Figs. 3 and 4. The result of this "improvement" was utterly to spoil the set's performance. These very small switches introduce a comparatively large amount of unwanted capacity on the high-frequency side of the set, quite sufficient at any rate to account for a variety of undesirable symptoms. If tune-standby or series-parallel switches are used, or if there is a switching arrangement enabling a high-frequency valve to be thrown in or out of circuit as desired, miniature switches of an unsuitable design should not be employed. Instead, anti-capacity switches should be mounted. These are specially designed so as to reduce to the smallest possible limits the amount of added capacity, and where they are employed no ill results need be anticipated. When later I removed the switches originally fitted and replaced them with others of low capacity design the set returned once more to its former good working. If you find

Quality RADIO COMPONENTS.

Profusely illustrated twelve page CATALOGUE just out. If your dealer cannot give you one send us a card with his name and address to receive it direct FREE and POST FREE.

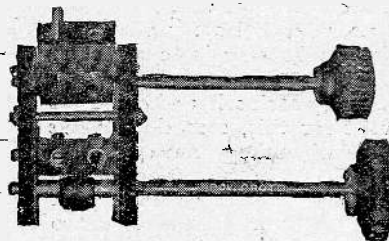

Prov. Protected.

CAM-VERNIER COIL HOLDER

Price 9/-, on base 1/- extra. With Reaction Reverse and Shorting Switch incorporated, 12/6. Postage 4d.

DUPLEX COILS

Postage 3d. each. Set post free.

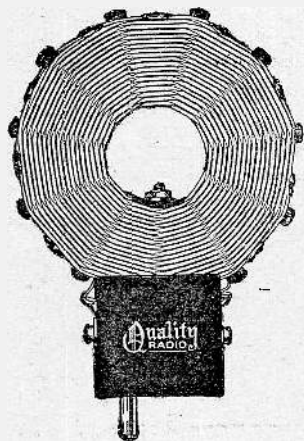

25	1/6
35	1/9
50	2/0
75	2/3
100	2/9
150	3/0
175	3/6
200	3/9

PANEL COIL HOLDER

(no base)

Back connections eliminating flex, 2 way 3/5, 3 way 5/5, N.P. 1/- extra.

Post 3d.

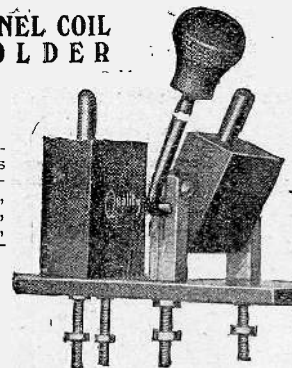

Drilling template with all.

GOSWELL ENGINEERING CO., LTD.,

12a, PENTONVILLE RD., LONDON, N.1. Liberal Trade Terms. Phone: North 3051

the high-frequency side of your set unsatisfactory and have switches of the midget kind, you will probably obtain very much better results either by doing away with them altogether or by substituting others of a type more suited for the purpose.

Gassing High-Tension Batteries

High-tension batteries provided with a covering of wax have as a rule no vent holes for the cells. When the battery is in action a certain amount of hydrogen gas is given off by each cell, and if there is no vent for this, something must give way when the pressure becomes excessive. The wax surface of one battery that I had in use last year became covered in a week or two with bulges caused by gas which could find no means of escape. In such batteries the ill effects of gassing are not as a rule noticed unless the amount given off is rather large. The gas produced by ordinary work while no very great amount of current is drawn from the battery may be so small that it does not give rise to any great amount of bulging. But if a battery is allowed to stand in the sun or near a fire, the increased pressure caused by the heat may be

sufficient to do it considerable damage. It is therefore desirable to see that high-tension batteries, especially those not provided with vent holes, are kept in cool places. When bulging does occur it is as

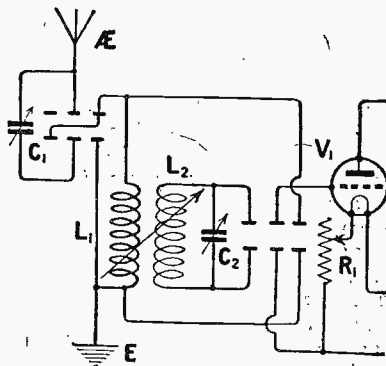

Fig. 4.—The introduction of two unsuitable switches in the manner shown may considerably decrease the efficiency of a receiver.

well to get rid of the excessive gas if possible. A tip that I have tried with fairly satisfactory results is the following, which, however, can be made use of only if the wax is sufficiently transparent to allow the

tops of the cells to be seen. Take a knitting needle and heat it up by holding it for a few moments in boiling water—one end should be thrust into a cork to act as a handle for protection of one's fingers. When it is hot, bore down with it through the wax or pitch covering of any cell above which there is a large bulge. In this way a vent hole is made which allows the accumulated gas a means of escape.

QUERIES.

Owing to the enormous increase in the queries received as a result of the publication of our new magazine, "The Wireless Constructor," the queries department is temporarily unable to deal with further queries, although every effort is being made to provide further facilities and a new staff.



PLUG-IN COILS— Give Selectivity

The type of inductance used has a considerable effect upon the selectivity of a receiver. Instead of tuning sharply with a steep resonance peak, high H.F. resistance in a coil flattens tuning so that two signals on proximate wavelengths are not separable. If you would gain selectivity you must employ coils which tune sharply. Such coils must have a very low H.F. resistance—these are the proved Diamond Sunflower. The particular design of the Diamond Sunflower is distinctive and novel—maximum air spacing, no shellac, and turns of high and low potential widely separated—produces a coil of minimum H.F. resistance and of extremely low loss. You gain utmost selectivity if you fit Diamond Sunflower Coils, because they tune with a steep resonance peak.

Note Swivel Mounting.

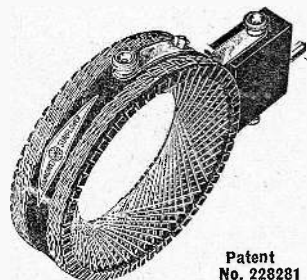

Patent No. 228281

Get Diamond Sunflower Coils from your dealer.

No. of Coil.	Approx. Wavelength in metres for Cond. in Shunt.	Price per Coil.
25	100-290	4/6
*30	142-377	4/8
35	185-465	4/9
*40	215-561	4/11
50	245-658	5/-
*65	310-820	5/3
*75	395-1,090	5/6
*85	500-1,350	5/9
100	619-1,495	6/-
*125	671-1,720	6/6
150	720-2,000	7/-
*175	850-2,400	7/3
200	980-2,780	7/6
*225	1,010-3,160	7/9
250	1,240-3,520	8/-
	Etc.	

DIAMOND WIRELESS LTD., 184a, Oxford Street, London, W.1.
Telephone: Museum 1380. Entrance Gt. Titchfield Street.

Barclays 907



Note the new Earthing Terminal

A 5 to 1 ratio Guaranteed

The U.S. Super Transformer has been proved under all conditions and in all stages to be the equal of any transformer on the market, irrespective of price. It is well designed and well finished, and after rigorous works-tests, is issued with a comprehensive guarantee.

Ask your Dealer!

18'6"



FROM ALL DEALERS

Super Transformer

From all Dealers or Direct from

THE U.S. RADIO Co. Ltd. DEPT. 2. 155, HIGH STREET, LEWISHAM, S.E.13

Phone: Lee Green 2404. Wires: Supertran, Lewis, London.

Louden Valves

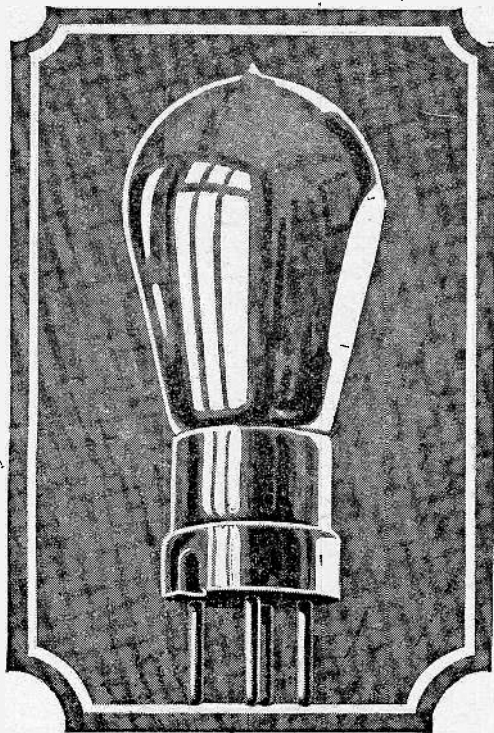

THE Louden Dull-Emitter at 13/6 combines the undoubted economical upkeep of the Dull-Emitter, the low initial cost of the ordinary "bright" valve, and the Silver Clear qualities common to all Loudens.

Its current consumption is only 0.1 amps, which is 1/7th of the consumption of the ordinary type of valve or 1/4th of that of the standard Loudens. This reduces your accumulator bills correspondingly, so that the small extra first cost is rapidly repaid!

Your accumulators will run very much longer without recharging, so you save trouble as well as money. The life of your accumulators also is greatly increased, as they discharge at a much slower rate when these valves are used.

No alterations need be made to your set to install these Valves, as they work off a 6-volt accumulator. Their use, therefore, does not involve disposing of an expensive battery.

The price of 13/6 brings a first-class Dull-Emitter within the reach of everybody. 13/6 is very little more than you have to pay for an ordinary "bright" valve.

It also has the Silver Clear qualities for which Loudens have justly become famous. Perfectly clear and distortionless reproduction is not the least of its good points.

Ask your nearest retailer for one, as its use is not only a revelation in clear reception but also a revelation in valve economy.

Should your local retailer for any reason be unable to supply you, write direct to us and your order will receive prompt attention.

Louden Dull-Emitter
Type F.E.R.1 for detection and L.F. Amplification.
Type F.E.R.2 for H.F. Amplification.
Filament Volts 5-6
Filament Amps. 0.1
Price **13/6**



Advt. of the Fellows Magneto Co., Ltd., Park Royal, London, N.W. 10.

In replying to advertisers, use Order Form enclosed.

HULLO EVERYBODY!!

NOTE:—ALL THESE GOODS POST FREE U.K. EXCEPT WHERE STATED. FOREIGN ORDERS MUST INCLUDE EXTRA FOR PACKING AND POST.

Aerial, 7/22, 100 ft.	2/6
50 ft.	1/8
Copper tape, 100 ft.	2/6
Basket holder and plug	2 for 1/10
Do. best quality, 2 for	2/3
Do. spike holder, 2 for	2/6
2-way coil stands	2/9
3-way coil stands	4/6
2-way nickel ex. handles	3/6
3-way nickel ex. handles	4/9
2-way geared	5/6
2-way Shipton cam vernier	3/6
3-way Shipton cam vernier	7/6
2-way Polar cam vernier	6/-
3-way Polar cam vernier	9/-
2-way cam vernier	3/6
Coil plugs, plain, 2 for	1/3
Shaped wedge	2 for 1/6
Do. Edison Bell 2 for	2/-
Do. nickel sides, 2 for	2/-
Do. fitted fibre, 2 for	1/8
Variometer and knob	2/6
Ebonite variometer and knob	2/6
Igranic	10/-
Edison Bell	10/-
Similar	8/11

Ormond rheostat	2/-
Ormond L.F.	14/6
Ormond .0005 and vernier	7/6
Rheostat C. & S.	1/3
Rheostat Raymond	1/6
Do. with dial	2/3
Finston, with dial	2/-
Shipton, 7 ohms	3/-
Do. 30 or 60 ohms	3/-
Potentiometer, 600 ohms	4/6

T.C.B.
(geared)

6 to 30 ohms	4/-
300 ohms	5/-

TWIN FLEX etc.

Red and black, 12 yds.	1/11
Miniature silk, 12 yds.	1/6
Lead-in, 10 yds.	1/3
Extra heavy, 10 yds.	2/6
Empire tape, 12 yds.	1/-
D.C.C. Bell wire, 20 yds.	1/6
Fibre strip, 36 in. by 1 in. 4 yds.	1/6

Brownie Phone Distributing Board
3/6
Takes 4 pairs 'phones.
Post free U.K.

SPECIAL!
Reflex Coils

35 8d.	200 2/9
50 9d.	250 2/3
75 1/-	300 4/3
100 1/2	400 5/3
150 1/8	500 6/3

unmounted.
Post 3d. each.

SUPER SELECTIVE Circuits

WATMEL Res. 10,000 to 100,000	3/6
"E.M.C." MICRO	4/-
Climax carth tube	5/-
Service detector	2/8

SOLID HOLDERS

Solid rod	1/3
Murray	1/3
Bretwood	1/9
H.T.C., under panel	1/6
H.T.C., over panel	1/9
Barrie anti-cap	1/3
Climax, under panel	1/6

CRITERION CONCERT COILS.

Low Self Capacity. Every turn and layer airspaced. Perfect for Reaction. Mounted on Plug.

25 2/-	75 2/9
35 2/3	100 3/-
45 2/3	150 5/-
40 2/6	200 6/-
50 2/6	250 6/6
60 2/9	300 7/-

Razor sharp tuning.

H.T. BATTERIES.

B.B.C., 60 volt	8/11
By post 10/-	
B.B.C., 36 volt	5/6
By post 6/6	
Best made, 60 volt.	6/11
By post 7/11	
Ever-Ready, 66 volt	13/6
Ever-Ready, 108 volt	22/6
Ever-Ready, 36 volt	7/-
Last 3 post free U.K.	

QUALITY GOSWELL RADIO COILS
Far more efficient than honeycomb or any other type of coil. Exceedingly strong and rigid, mounted on standard ebonite plugs. Brown finish, no wax or shellac used. MOUNTED.

25	1/6
35	1/9
50	2/0
75	2/3
100	2/9
150	3/0
175	3/6
200	3/9

Post 3d. Coil.

GOSWELL (QUALITY)

Valve Legs, Set 4	1/3
Valve Holder	1/9
2-way Cam Vernier	9/-
3-way Cam Vernier	12/6
3-way Ordinary	7/6
2-way Panel	3/-
3-way Panel	5/-
Basket Holders	1/4

IMPORTANT
By arrangement with Messrs. Bower Electric, I offer genuine 5 PIN
THORPE K4 17/6
(Unidyne Valves.)
5-pin valve holder 1/3
2 valve Unidyne receiving set built complete, aerial tested and guaranteed efficient, including coils and valves for B.B.C. stations, £9 9s. Od.
One valve set, complete, £6 6s. Od.
Sets of parts supplied from £3 15s. Od.
Post free U.K.

VALVES
Myers Universal 11/-
Marconi, Ediswan, B.T.H., Cossor, Mullard, etc.
BRITISH VALVES.
All Bright Emitters, **11/-**
D.E.R. all makes 18/-
'06, all makes 21/-
Power Valves
22/6 to 30/-
Valves posted buyer's risk.

HEADPHONES.
Reduced prices.
British B.T.H. 20/-
Brandes' Matched Tone 20/-
General Radio 20/-
Brown's F Type 20/-
Sterling's 22/6
All 4,000 ohms.
Highest quality finish.
Post free U.K.

TELEFUNKEN.
Adjustable, 4,000 ohms, only genuine when bearing No. E.H. 333 on each ear-piece. These 'phones are lighter than a feather, and simply wonderful for reception. Post price U.K. 17/11 pair.

POLAR
Variable Condensers.

.001	10/6
.0003, .0005, .00025	18/6
Micrometer	5/6
2-way cam vernier	6/-

Post Free U.K.

IGRANIC

Rheostat	4/6
30 ohms	7/-
Potentiometer	7/-
Variometer	10/-

COILS.

25 5/-	200 8/8
35 5/-	250 9/-
60 5/2	300 9/5
75 5/6	400 10/3
100 7/-	500 10/6
150 7/10	

Post free U.K.

"WONDER"
Aerial Wire, 49 strands. Special alloy Phosphor Bronze, for frame, indoor, or outdoor. Non-corroding. 110 ft. 3/3. By post 3/8.
"LISSEN."
Post free U.K.
Lissen Minor 3/6
Lissenstat 7/6
Lissen Universal 10/6
Push and pull 2/9
Do., 5 point 4/-
Series Parallel 3/9
Var. grid leak 2/6
Anode Resistance 2/6
See Transformers.

MIC-MET 6/-
DETECTOR
Post free U.K.

L.F. TRANSFORMERS

Eureka Concert Grand	30/-
Eureka Second Stage	22/6
Igranic Shrouded New Model	21/-
Powquip, see illustrations.	
Lissen T1, for 1st stage	30/-
Lissen T2, for 2nd stage	25/-
Lissen T3, Popular Model	16/6
Forno Shrouded	18/-
Forno Open Type	12/6
Portland	12/6
Wates Supra	12/6
General Radio 33	15/-
Super Success (black)	21/-
Royal Transformer	20/-
Raymond 1st stage 5-1	12/6
Raymond 2nd stage 3-1	12/6

£50 REWARD
given if the
DR. NEPPER
PHONES SOLD HERE ARE NOT GENUINE!
BEWARE OF FRAGILE IMITATIONS!!
(Injunctions obtained.)
Adjustable diaphragm, detachable receivers, double leather-covered head-springs, long flexible cords, nickel-plated parts. Very comfortable fitting to the head. Per pair, 12/11. Post 3d. pair, U.K.

STERLING
Square Law, with Vernier.
.001 30/6
.0005 25/6
.00025 23/6
Post Free U.K.

MANSBRIDGE CONDENSERS
Octopus, Tested at 350 D.C.
01 2/3. T.C.C. 25
3/-, 2 nfd. 5/-, 1nfd. 3/8
1 mfd. 3/1. 2 mfd 4/6. .25
3/6. Post 2d. each.

"HOVIMO" CRYSTAL VALVE
The "Hovimo" Crystal Valve can be used in an instant and is easily fitted to any set, being equally excellent for crystal sets, and for circuits employing crystal rectification. No batteries are required 3/6

LISSEN COILS

25, 35	4/10
60	5/-
75	5/4
100	5/4
150	6/9
200	7/-
250	8/5

Post free U.K.

"BROWNIE" TELEPHONE DISTRIBUTION BOARD.
Table Pattern, takes 4 pairs of 'phones, 3/6.

WATES MICROSTAT
New Improved Model
Post Free. 2/9
"MICROMETER"
Detector 2/3
enclosed.

ACCUMULATORS
For CALLERS ONLY at present.

Rheostat with Dial Extra value 2/6
Bretwood Valve-holder 1/9

Manchester "Powquip" 15/6
Ormond 14/6

Shrouded "Powquip," 18/-
Standard "Powquip," 14/6

"R.I." NEW MODEL IN SEALED BOX

Don't Buy Otherwise.
Post 25/- Free
FERRANTI L.F.
BETTER THAN THE BEST
17/6

IMPORTANT NOTICE
TRADE POST ORDERS.
TRADE ORDERS OF NOT LESS THAN £2 in value executed from this page less 20 per cent., plus postage. Cash with order only.

NO POST ORDERS TRADE.

EBONITE PANELS
3-16th in.
6x6 1/8
10x8 3/6
7x5 1/8
12x9 5/-
8x6 2/6
12x12 5/9
9x6 2/9
14x10 5/9
PANELS DRILLED FREE WITH ORDERS OVER 20/-
Please send diagram.
West End stockist of Edison Bell, Igranic, Goswell (quality), Polar, Jackson Bros. (J.B.), Marconi, Cossor, Mullard, Ediswan Valves, Sterling, B.T.H., McMichael's, Lissen, Dubilier, T.C.B., Shipton parts.

FIXED CONDENSERS

Edison Bell, .001	1/3
.0001 up to .0005	1/3
.002 up to .006	2/-
Grid leak and clips	1/6
.0003 and grid leak	2/6
Dubilier, .001 to .006	3/-
.0001 up to .0005	2/6
.0003 with grid leak	5/-
Anode res. on stand	5/6
(50, 70, 80, 100,000 ohms) Raymond ebonite base.	1/1
.0001 up to .0005	1/3
.001 up to .006	1/3
Grid leak and clips	1/6
.01 and .02 each	4/6
2 MFD.	3/10
1 MFD.	3/8
.25 MFD.	3/8

BRASS GOODS (with nuts)

Flush panel sockets, doz.	1/3
'Phone terminals, doz.	1/2
Pillar, large doz.	1/3
Pillar, small doz.	1/1
W.O. pattern	1/3
Terminals, nickel doz.	2/-
Spade terminals doz.	1/-
Pin terminals doz.	1/-
Spade tags doz.	6d.
Studs, nuts and washers doz.	9d.
With switch arm	1/6
Shorting plug	8d.
Bus bar, 1/16th sq., 12 ft.	1/-
Nickel switch arm	1/3
(with studs and nuts)	2/-

BURNDEPT PARTS

Detector	4/-
Dual rheostat	7/6

McMICHAELS PARTS

100,000 ohm res. and clips	2/6
2 meg. leak	2/6
Dual rheostat	7/6

RIGHT OPPOSITE
DALY'S
GALLERY DOOR
Phone: GERRARD 4637

K. RAYMOND
27, LISLE STREET,
LEICESTER SQUARE, W.C.2
No responsibility accepted on post orders unless cheques and postal orders are crossed and made payable to the firm. Moneys sent must be registered

HOURS OF BUSINESS:
DAILY . 9 to 7.45
SUNDAY . 10 to 1

HULLO EVERYBODY!!

REVOLUTION IN VARIABLE CONDENSERS SQUARE LAW LOW-LOSS (SQUARE-LO-LOSS) With VERNIER.

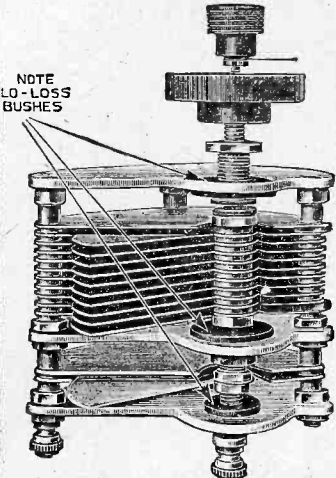

The only Condenser with the Low-Loss Bushes. Electrical losses reduced to a minimum.

Full capacity as rated.

Exceptional Low Capacity.

The Condenser for short wavelengths.

SQUARE LAW WITH VERNIER.
Including Knob and Dial
TRADE DISCOUNT 20 per cent.

•0005 - - 7/9
•0003 - - 7/-
Post 6d. Set.

RAYMOND VARIABLE CONDENSERS SQUARE LAW.
One-hole wiring. Aluminium ends. WITH VERNIER.
Ebonite Bushes. Highly recommended. WITHOUT VERNIER.

•001	8/9	•001	7/7
•0005	7/9	•0005	5/9
•0003	7/-	•0003	5/3

Post 6d. Set Ebonite ends 1/- extra. Ebonite ends 1/- extra. Prices include Knob and Dial.

DE LUXE ORDINARY
Complete with Knob and Dial.

•001 alvm.	6/11	Trade Discount 20 per cent. on Variable Condensers. NOT LESS than 6 supplied. Cash with order.
•0005	5/6	
•0003	4/11	
•0002	4/6	
	Post 3d. Set.	

TWIN CONDENSERS
Equal parts of •0005, •0003 & •00025. With Knob and Dial. Ebonite Ends.

•0005 ebonite ends	18/11
•0003	12/6
•00025	12/6

LONDON'S LARGEST STOCKIST OF JACKSON BROS.'
J.B. Variable Condensers. Complete with Knob and Dial. SQUARE LAW. STANDARD.

•001	9/6	•001	8/6
•0005	8/-	•0005	7/-
•0003	6/9	•0003	5/9
•0002	5/6	•0002	5/-

Other sizes as advertised by "J.B." Post 4d.

HEADPHONES

ERICSSON E. V. CONTINENTAL. Your favourite. phones. Entirely NEW. Most beautifully finished, exquisite tone. Ridiculous Price per pair (4000 ohms) **12/11 POST FREE.**

R.I. DETECTOR 6/-
All orders in rotation.

"RE-ECHO"
Crystal Set. Sloping cabinet. Fitting for Chelmsford. Splendid results. 17/6, including aerial wire, lead-in, and insulators. Post free U.K.

"WELDBANK" (Chorley Rubber Co.)
EBONITE.
Test pressure 500 volts. Specific gravity 1.35.

IS SOLD IN OUR STOCK SIZES

LOUD SPEAKERS.

C.A.V. Tom 30/-
Tit 30/-
C.A.V. Junior 55/-
Sterling Baby 55/-
Sterling 30/-
Dinkie 30/-
Amplion Junior 27/6
Amplion 25/-
Dragonfly 42/-
Dulcevox 42/-
All models stocked of leading makers.

N & K
4,000 ohms. Guaranteed genuine and stamped. **12/11 pair.** Post 6d. pair.

GENUINE 'BRUNET'

L.F. Transformers. 3-1, Primary 5000. Secondary 15,000. 5-1, Primary 5000. Secondary 25,000. each **13/6**

Warning! Note name RAYMOND on windows. You will not be able to buy these goods otherwise. Nearest Tube Leicester Square. This address is at the back of Daly's Theatre.

OPEN WEEKDAYS 9 TO 8. SUNDAYS 10 TO 1.
3 COLUMNS FOR CALLERS ONLY
ALL POST ORDERS FROM OTHER COLUMNS.

Insulated Hooks 2 for 1d.	TERMINALS (Complete)	ACCUMULATORS.
Egg Insulators 4 for 3d.	W.O., Pillar, Phone, brass, 1d. each nickel	2 v. 40 amps. 9/6
Insulated Staples 5 a 1d.	2d. each stop and valve Pins, 1d. nuts,	4 v. 40 amps. 16/6
Battery Links 4 for 2d.	varicus, 6 a 1d.	4 v. 60 amps. 18/6
6 ft. Phone Cords 1/-, 1/3, 1/6	Valve Sockets 1d., 1 1/2d.	4 v. 80 amps. 23/6
Sleeving yd. 3d.	Flush panel do. 1d.	6 v. 60 amps. 27/6
Empire Tape 12 yds. 6d.	Spade Tags 6 a 1d.	6 v. 80 amps. 33/-
Red and black flex 12 yds. 1/6	Do. Terminals 2 for 1 1/2d.	6 v. 105 amps. 38/6
Wander Plugs 1d.	Do. Pins 2 for 1 1/2d.	Hart's Stocked. All High Quality.
Tape Aerial 10 ft. 1/10	Screws and nuts 2 a 1d.	
7/22 hard drawn, 100 ft. 1/10	Switch arms 7d.	
1/16 Bus Bar Hank Lead-in tubes 6d.	Nickel arms 10d.	
Ormond Rheostat 1/8	Studs, complete 2 a 1d.	
C. & S., Good value Raymond, with dial 1/11	Phone connectors 1d.	
Twin silk flex, 6 yds. Eaby 2-way coil stand 1/9	2 B.A. Rod ft. 2d.	
Do. 3-way coil stand 3/8	4 B.A. Rod ft. 2d.	
2-way ex-handles nickel 2/9	Valve windows 4d.	
3-way ex. handles, nickel 4/6	Washers 12 a 1d.	
H.F. Transformer, B.B.C. 2/6	Shorting plug & socket 3d.	
Do. Chelmsford 2/9	Shellac 5d.	
D.P.D.T. Panel switch 1/-	Ormond (Neurodyne) 2/-	
S.P.D.T. Panel switch 10d.	Colvern 3/6	
D.P.D.T. China base 7d.	Success 3/6	
S.P.D.T. China base On and Off switch 1/-	Vernier (Colvern) 2/6	
Legless valve holder Solid rod valve holder 1/3		
H.T.C. both types. Basket holders, 7d. Also at 10d., 11d., Spike holders 7d., 9d. Knobs, 2 B.A. 2d. Brass coil former 2/3		
4.5 batteries 4d., 4 1/2d. Dr. Nesper 'phones 11/9		
Telefunken Type 8/11		
N. & K. Pattern 7/11		
Glazite 1/6		
Breast drills 4/9		
Set of drills 1/2		
Screwdrivers 3d.		
Spanners (5) 4 1/2d.		
Pliers 10d., 1/-		
7 waxed coils 1/8		
5 waxed coils 1/4		
Whiskers 1d., 2d., 3d.		
Set of 4 2d.		
Copper foil 1 foot 2 1/2d.		
Mansbridge 1 mfd. 3/3		
Do. 2 mfd. 3/9		
Do. 25 2/8		
Copper earth tube 3/6		

SPECIAL!
60 v. H.T. Batteries, 4/11, 5/11, 6/11.

CRYSTAL SETS.
5/11, 6/11, 7/11, 8/11 up to 30/-

H.T. BATTERIES.
B.B.C. 60 v. 8/11
B.B.C. 36 v. 5/6
Eveready 65 v. 13/6
Eveready 10 v. 22/6
Eveready 36 v. 8/-
Do. 4.5 6/6 doz.

SHAW'S HERTZITE
with W. Shaw facsimile signature. None genuine without. In sealed box. Callers 8d.

D.C.C. WIRE
Per 1/2 lb. Reel.
18 or 20 g. 9d.
22 g. 10d.
24 g. 11d.
26 g. 1/-
28 g. 1 1/2
16 D.C.C. 2/6 lb.

SET OF 5 COILS.
Extra air spaced 1/2 in. thick 1/8
Duplex Waxless, wave-lengths marked No. 25, 35, 50, 75, 100.

CHELMSFORD WITH
above specification. 10d., 11d., 1/-

CRITERION COILS.
Set of 5 8/11
25, 35, 50, 75, 100
Every turn and layer air spaced, perfect for reaction, low self-capacity mounted on plug. Also sold separately.

ODDMENTS of all KINDS
all cleared out daily at cheap prices. Not obtainable unless shop bears the name RAYMOND on windows, etc.

EBONITE, 3/16 in Stock Sizes.
Cut to size. 1d. sq. in.
6x6 1/4 12x6 3/-
7x5 1/4 12x9 4/3
8x6 1/10 12x12 5/6
9x6 2/- 14x10 5/6
10x8 3/-
1-in. also Stocked.

SWITCH ARM, one-hole fixing. 12 Studs, 12 Nuts, 12 Washers. Lot 10/-

COIL PLUGS, EBONITE.
Fitted Fibre 7d.
Wedge Shape 7d.
Edison Bell 11d.
Plaincoil Plugs 4 1/2d.
Also 5d., 6d., 7d. each.
Fibre Strip 2d.
(36 in. by 1 in.)
Empire Tape, doz. yds. 6d.

RAYMOND FIXED CONDENSERS.
•001, •0001 to •0005, 10d.
•002, •003, •004 1/-
•006, 1/3, •01, 1/9, •02, 1/9.
Ebonite Base Terminals.

MICROSED DETECTORS.
Micrometer 1/6
Half Gal 1/-
Small Brass 8d.
Large Brass 1 1/3
Nickel 10d. to 1/6
Burndept 4/-
Shaw's Genuine Hertzite 10d.
Uralium 1/-
All known makes.
4 Whiskers (1 gold) 2d.
Gold and Silver do. 2d.
7 Waxed Coils 1/8
5 Waxed Coils 1/3
(For B.B.C.)

SPECIAL!
Vernier 2-way Coil 3/3
Stands 5/3
Geared do. 5/3

HEADPHONES.
Ericsson's EV Continental 4,000 ohms 11/9

RIGHT OPPOSITE
DALY'S
GALLERY DOOR

K. RAYMOND
27, LISLE STREET,
LEICESTER SQUARE, W.C.2

HOURS OF BUSINESS:
DAILY - 9 to 7.45
SUNDAY - 10 to 1
Phone: GERRARD 4637

No responsibility accepted on post orders unless cheques and postal orders are crossed and made payable to the firm. Moneys sent must be registered

In replying to advertisers, use Order Form enclosed

Using the Potentiometer

By R. W. HALLOWS, M.A., Staff Editor.

An interesting description of a few of the many ways in which that much neglected little instrument, the potentiometer, may improve the working of your set.

DO you use a potentiometer? If you do not you may be failing to make use of one of the greatest aids to obtaining efficiency, for there is hardly a set, crystal, single-valve or multi-valve, whose performance is not sometimes improved by the proper employment of this little instrument. If you *do* already make use of a potentiometer, are you quite sure that you make the most of its help? In this short article I want to point out some of the ways in which the potentiometer may be employed to give those very fine adjustments of important potentials which make so much difference to the quality of reception and to the sensitivity of the set.

How it Functions

First of all, what is the potentiometer? In spite of its rather forbidding name it consists of nothing more than a resistance of wire or carbon provided with a moving contact of some kind. A glance at Fig. 1 will show readily how it works. In the drawing we see that a resistance of 300 ohms is connected directly across a six-volt battery. You need not be afraid that by doing this you are short-circuiting the battery. By Ohm's Law the current flowing, volts divided by resistance, will be

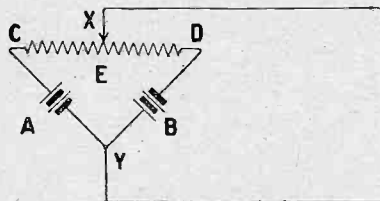

Fig. 2.—By means of this arrangement, positive or negative potential is obtainable.

6/300ths of an ampere or 20 milli-amperes. Now since the top of the resistance seen in the drawing is connected to the positive terminal of the battery and its lower end to the negative, the ends of the resistance winding will be at the same potentials as the terminals of the battery. That is, the top of the

coil will have a value of + 6 volts, whilst the bottom will be at zero potential. Across the windings the drop in voltage will be perfectly regular—that is to say, half way down them the potential will be + 3 volts, three-quarters of the way down it will be + 1½ volts, and soon. By moving the slider, represented

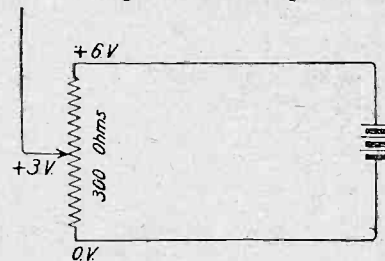

Fig. 1.—A simple potentiometer circuit for applying positive potential.

in the drawing by an arrow, up and down the coil we can tap off any potential that we like between 6 volts positive and zero.

Obtaining Positive or Negative Potential

The potentiometer arranged as shown in Fig. 1 enables us only to obtain a varying amount of positive potential. We can, however, arrange the potentiometer so that either positive or negative potentials may be obtained. Fig. 2 shows how this is done. The two dry cell batteries A and B, each having a value of 3 volts, are wired in series and a connection, Y, is taken from the junction between them. If the slider X is placed at the left hand end C of the resistance coil, the easiest path for current will be from Y through battery A to C and thence to X. In this case X will be 3 volts more positive than Y. If we move the slider right across to the other end D, the position of affairs will be reversed. The easiest path will now be from Y through battery B to D, and X will be 3 volts more negative than Y. When X is placed in the middle position E between C and D, the batteries are working against each other, their potentials cancel out and X

and Y are at the same potential. By moving X from E towards C we can obtain any potential between 0 and + 3 volts, whilst if it is moved from E towards D the value will vary from zero to -3 volts.

Another Method

Exactly the same result can be obtained as shown in Fig. 3 with a potentiometer whose windings are provided with a central tapping. Here two dry cells are shown in use and the end C is 3 volts positive to D. Since the voltage drop across the resistance is regular, the centre point E is 1½ volts more negative than C and 1½ volts more positive than D. If the slider X is placed opposite E, X and Y will be at the same potential. When it is moved from E towards C, X may be made anything from 0 to 1½ volts more positive than Y, and if it is moved from E in the direction of D, the potential of X can be varied between nothing and 1½ volts more negative than Y.

Improving Crystal Sets

Fig. 4 shows how reception with a crystal set can sometimes be improved by means of a potentiometer such as that seen in Figs. 2 and 3. In the early days of wireless, when carborundum was fairly extensively used, a potentiometer

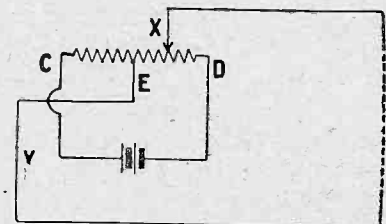

Fig. 3.—Using a potentiometer with centre tap, potential may be varied as in Fig. 2 with the use of only one battery.

was seen on every receiving set. To-day, however, owing to the use of various forms of galena crystal, it is hardly ever seen, since quite satisfactory results are obtainable without it. But as a matter of fact there is hardly a crystal on the

For very accurate H.F. work

Users of H.F. Receivers appreciate how extremely difficult it is to bring circuits into resonance. The large tuning condenser which permits only a comparatively large variation of capacity tends to make the accurate balancing a matter of chance. It is quite simple when searching for Distant Signals to pass over the correct dial reading. **But if you use a low maximum capacity condenser which gives you very fine tuning it will come as a pleasant surprise just how easily you can tune in weak signals.**

COLVERN Tuning Condenser BRINGS IN THE DISTANT STATION

Fine tuning control reduces the search for distant stations to extreme simplicity. The perpetual heterodyning of the carrier wave in the endeavour to find the silent midway point is an experience which need be yours no more if you utilise the Colvern General Purpose Vernier to give you fine tuning. Use the Colvern only across reaction, fit one in parallel with your large tuning condensers and you will demonstrate how extremely sensitive your set is to fine control. Remember that a vernier should not be in association with the main condenser.

Fit an independent vernier; your dealer sells them—the Colvern COLLINSON'S PRECISION SCREW CO. LTD.

Macdonald Rd., Walthamstow, London. E.17. Tel.: Walthamstow 532.



Price 2/6

Barclays 878

SIEMENS LOUD SPEAKERS

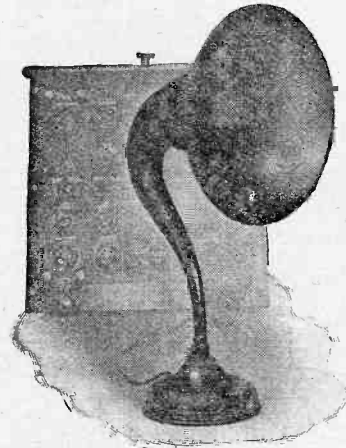

Renowned for Clearness and Purity of Tone.

PRICES:

120 ohms, 42/6; 2,000 ohms, 44/-; 4,000 ohms, 45/-

Obtainable from all leading dealers.

SIEMENS, BROTHERS & CO., LTD., WOOLWICH, LONDON, S.E.18.

On Building an H.F. Receiver

"Using the type of valve holder wherein the valve sockets are embedded in a moulded insulating material, the capacity between grid and anode was 1 1/2 times greater than the capacity if employing the valve holder with sockets fixed on ebonite and separated by air. By way of a further interesting comparison, the capacity between the grid and anode sockets of the former valve holder is six times greater than the capacity in the latter instance."

A casual glance at the H.T.C. low capacity valve holder shows that a reduction of capacity is effected to a much greater degree. That so great a reduction introduces very high efficiency into your receiver goes without question; and the better results you will obtain by utilising the H.T.C. low capacity valve holder is so marked that for H.F. work they are absolutely essential.

H.F. amplification may be considerably hampered by high capacity at the valve. In fact, capacity effects at the heart of your receiver may completely deprive your valves of the power to oscillate on the short wavelengths. It may shorten effective receiving range and in many instances—especially where embedded sockets are used—introduce distortion.

You can only get the best from your set if you employ H.T.C. Low Capacity Valve Holders.

Remember also that when you are using the popular Plug-in Type H.F. Transformer make no mistake—mount them in conjunction with the H.T.C. low capacity Valve Holders.

Type A (above panel), templates supplied 1/9
Type C (below Panel) " " 1/6

Your dealer may try to persuade you that something he has in stock is just as good. H.T.C. Products are unrivalled for their electrical performance. Rather than receive any substitute from your dealer send to the manufacturers—

H.T.C. ELECTRICAL CO. Ltd.

Telephone: Battersea 374.

2-2a, BOUNDARIES RD., BALHAM, LONDON, S.W.12

In replying to advertisers, use Order Form enclosed.

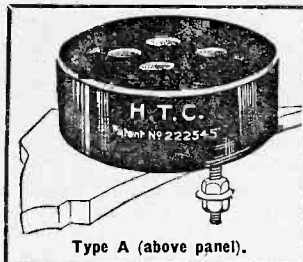

Type A (above panel).

TRADE ENQUIRIES INVITED

INSIST ON H.T.C. PRODUCTS

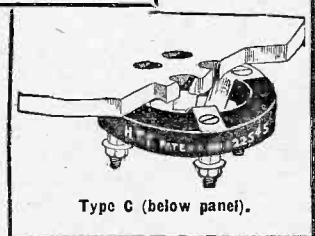

Type C (below panel).

WARNING!

Purchasers of Low Capacity Valve Holders are notified to beware of imitations. It is very necessary when buying to look for the name H.T.C. on the template, without which no Valve-Holder is the genuine and original H.T.C. It may be taken that colourable imitations—simply because they are imitations—will not nor cannot give efficiency which is inherent to the H.T.C.

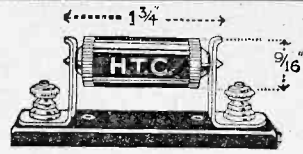

FIXED DETECTOR OF MERIT.

Prov. Pat. 30258/24.

The construction peculiar to the H.T.C. Crystal Detector gives it ability to give extraordinary power and sensitivity. Mineral crystals of extraordinary merit are alone used. Each H.T.C. Detector is tested on actual Broadcast against a standard of exceptionally high performance.

H.T.C. Fixed Detector	s. d.
Complete with Ebonite Base Clips	3 6
and terminals	4 6
Detector and Clips only	3 9

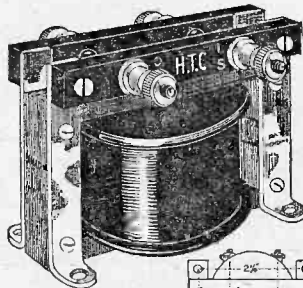

LENGTH • 2 1/4"
HEIGHT • 2 1/4"

A DISTORTIONLESS L.F. TRANSFORMER

Price 15/-

Barclays 877

The first Valve ever made was produced in the Ediswan laboratory

Sound production

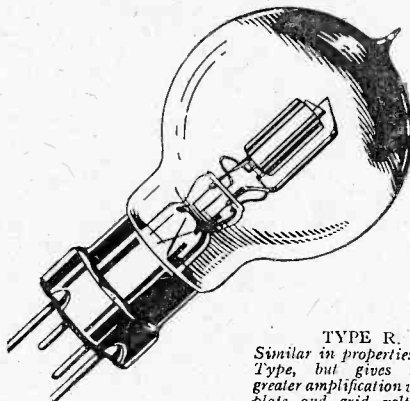

TYPE R.
Similar in properties to A.R. Type, but gives somewhat greater amplification with same plate and grid voltages.
Price 11/-

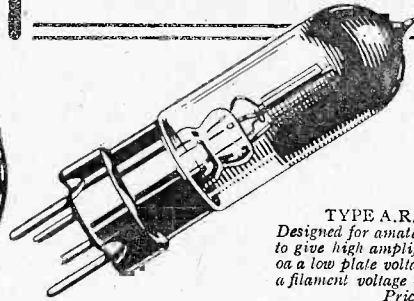

TYPE A.R.
Designed for amateur use to give high amplification on a low plate voltage and a filament voltage of 4.
Price 11/-

35 YEARS ago it was discovered that an electric bulb could produce sound as well as light. The story of "Ediswan" valves started with that discovery. Every later development has been inspired by the same pioneer spirit. To-day the valves perfected in "Ediswan" laboratories are still "first." Their reliability in results and in service is the outcome of experiment backed by sound production at every stage.

Something New



TYPE A.R.D.E.

The Ediswan A.R.D.E. Valve of the dull emitter type (2 volt), is now being especially manufactured both for H.F. and L.F. work. The respective characteristics of the Valves are as follows:—

	L.F.	H.F.
Filament Volts	1.8-2.0.	1.8-2.0
Filament Current	0.3 amp	0.3 amp
Anode Volts	30-100	20-100
Total Emission	16 m.a.	16 m.a.
Amplification factor	5.0	9.5
Approx. impedance	15,000 ohms.	40,000 ohms.
Normal working slope	0.40 ma/volt	0.30 ma/volt

The distinguishing marks are a green line for L.F. and a red line for H.F. on the side of the bulb. This line will also indicate the Anode pin of the cap. Price 18/- each.

"Ediswan" valves are designed for use with every type of set. Best results are obtainable with "Ediswan" Radiophones in conjunction with a Televox or Dulcivox Loud Speaker.

THE EDISON SWAN ELECTRIC CO., LTD.,
Queen Victoria Street, London E.C.4.

EDISWAN VALVES

ALL LEADING DEALERS STOCK "EDISWAN."

702/32

market whose working is not occasionally improved by the application of either a positive or a negative potential across it. Most galena crystals become more sensitive under the influence of a

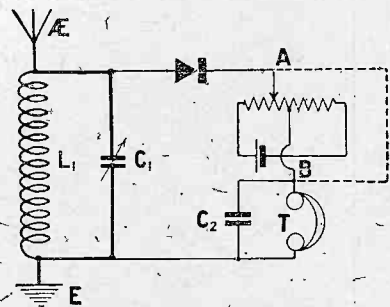

Fig. 4.—Crystal sets are often improved by the addition of a potentiometer as shown.

positive potential of a fraction of a volt. It will therefore be sufficient to use a single cell from a large flashlamp refill with a centre connection potentiometer, or two cells in series if the arrangement shown in Fig. 2 is employed. The efficacy of the potentiometer is best tested in the following way. Rig up the circuit shown in Fig. 4 and cut the potentiometer out of action by short circuiting the points A and B. Now tune in a very weak signal. When this has been done remove the short circuiting lead and try the effect of moving the slider of the potentiometer very gradually first in one direction and then in another. Very often an adjustment will be found which brings up the weak signals to a greater strength than they were without the potentiometer. Upon strong signals the difference will not be so marked.

Controlling Oscillation

Let us see next what the potentiometer can be made to do in the valve set. Fig. 5 shows the way in which the instrument is most commonly used—and in many cases abused. A high frequency

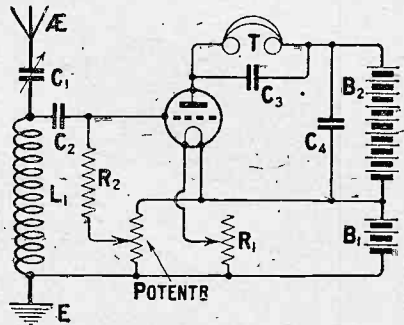

Fig. 6.—A valve detector circuit in which a potentiometer is employed to adjust grid potential.

valve, such as that seen in the drawing, whose plate and grid circuits can be sharply tuned will tend to oscillate when the two are brought into resonance, provided that there is not an undue amount of resistance in the coils and their connections, and that the variable condensers are efficient. Oscillation can be prevented by making the grid of the valve rather positive. The effect of this is to produce a flow of grid current which damps the oscillations. If, however, the positive potential upon the grid is too large, distortion may result. It is a sound working rule that a stabilising potential of two volts positive is the maximum that should ever be used and that one should aim at never employing a positive potential exceeding 1 volt. If the set cannot be held down in this way steps must be taken to produce

of the rectifying valve direct to low tension positive.

The grid potential can be varied by altering the resistance of the leak, that is, either by using a variable gridleak or by fitting fixed leaks of different values. Very much finer adjustments are made possible by the arrangement shown in Fig. 6, where, instead of being connected directly to low tension positive, the lower end of the leak is taken to the slider of a potentiometer. This arrangement will be found particularly useful for short wave work, where the grid potential of the rectifying valve is apt to be somewhat critical. When the potentiometer is used a suitable value for the leak is about 1 megohm.

Controlling Negative Bias

Another position where the potentiometer can be employed

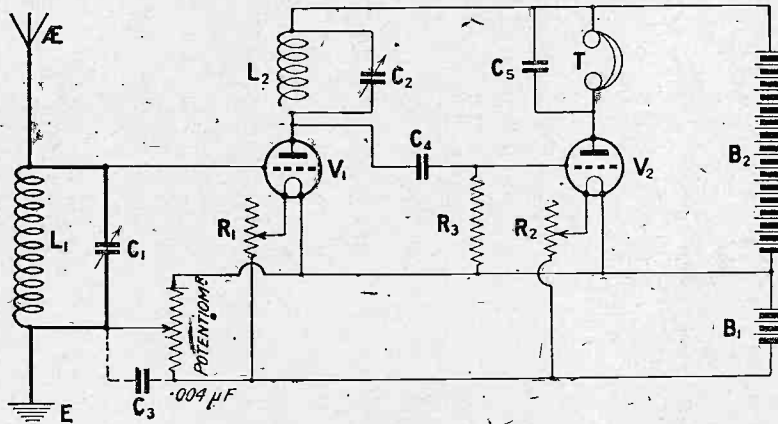

Fig. 5.—A common method of controlling oscillation by means of a potentiometer.

stability by other means, and not by excessive use of the potentiometer. It is advisable, by the way, that where the potentiometer is used for regulating the grid potential of a high frequency valve a condenser should be fitted in the position shown by the dotted lines in the drawing, that is, between the slider and low tension negative. This condenser acts as a bypass for high frequency oscillations, which would otherwise have to pass through a number of turns of the resistance coil.

Adjusting Grid Potential in a Detector Circuit

But the use of the potentiometer is by no means limited in the valve set to produce stability on the high frequency side. In Fig. 6 is seen a way in which it can be employed to advantage in either single-valve sets or multi-valvers. The usual practice is to connect the gridleak

with most satisfactory results is that seen in Fig. 7, where it is used for regulating the grid bias of a note magnifying valve. In the majority of sets fitted, as all sets should be, with a grid biasing battery no form of fine adjustment is provided. The simplest arrangement is to connect the positive end of the grid battery straight to low tension negative. This works pretty well, and it is certainly much better than having no grid battery at all. It has, however, the disadvantage that no adjustment can be made to compensate for the falling off in the battery's E.M.F. which takes place in course of time. Another quite good arrangement is to tap the grid battery and make use of a selector switch. The drawback here is that with dry cells you cannot obtain steps of less than 1½ volts. The use of the potentiometer as shown

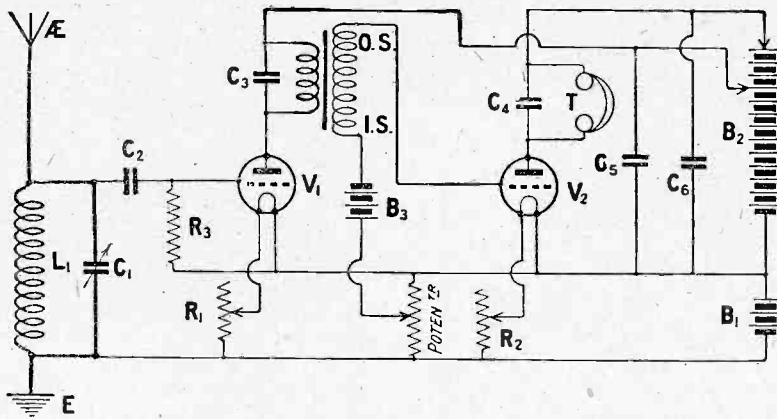

Fig. 7.—A very convenient means of controlling negative grid bias in a low-frequency amplifier.

in Fig. 7 simplifies matters immensely, since it enables very fine adjustments to be made. Any falling off in the voltage of the grid battery can be compensated for by moving the slider a little towards the negative end of its travel, and the grid bias can be so adjusted that perfectly pure reception is obtained, whilst the drain upon the high tension battery is cut down to the smallest possible limits.

These are a few suggestions for using the potentiometer for obtaining both better reception and increased selectivity in the set. They are by no means the only uses to which it can be put, but they serve to show that if it is properly employed it is one of the wireless man's best friends.

The Double Circuit Neutrodyne Receiver

SIR,—It may interest you to know that I have recently completed the Double Circuit Neutrodyne Receiver, described by Mr. John Underdown, in November issue of MODERN WIRELESS. I am situated within 3 miles of the Cardiff station, but can get all the B.B.C. stations

except 2LO without interference from 5 WA, as well as Hamburg, Frankfurt, Zurich, Madrid and Petit Parisien. In the latter case there was a faint undercurrent of 5 WA, but this was not strong enough to interfere much. I have also had several amateur stations. Later I hope to get the H.F. transformers and coils to include the higher wavelengths and thus include other stations. Reaction control is so wonderfully smooth,

and my wireless friends are many of them anxious to make a similar circuit. This is the first valve set I have made, and was chosen for its selective qualities. I would like to take this opportunity of expressing my appreciation of MODERN WIRELESS and the *Wireless Constructor*, both of which are responsible for many happy and instructive hours.—Yours truly,

OLWEN PROGER (Miss).
St. Fagans, Glamorgan.

The Aristocrat of Receiving Sets

THIS Supersonic Heterodyne Receiving Set is the aristocrat of the Western Electric Economy Series of Radio Instruments.

It contains seven Wecovalves, and operates with a Frame Aerial which together with a Battery Box and head-receivers, forms the complete equipment.

Broadcast telephony can be received from all British and Continental Stations operating on 300 to 3,000 metres, the distance range usually being limited only by atmospheric conditions.

It should be noted that being a Frame Aerial Set, the whole equipment is portable and can be taken from room to room.

The No. 44002 Set is designed for head-receiver reception, but can be used in conjunction with a power amplifier for operating Loud Speakers. The Supersonic Heterodyne principle, as used in this instrument, results in a wonderful degree of selectivity and sensitiveness.

Price (complete) £75.

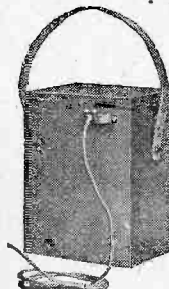
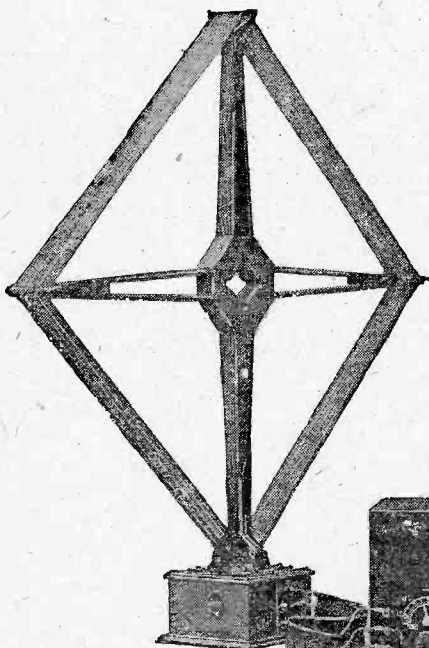

Western Electric Company Limited,
CONNAUGHT HOUSE, ALDWYCH,
LONDON W.C.2.

CENTRAL, 7345 (9 lines).

Branches: Birmingham, Leeds, Manchester, Newcastle, Glasgow, Cardiff, Southampton, Liverpool, Dublin.

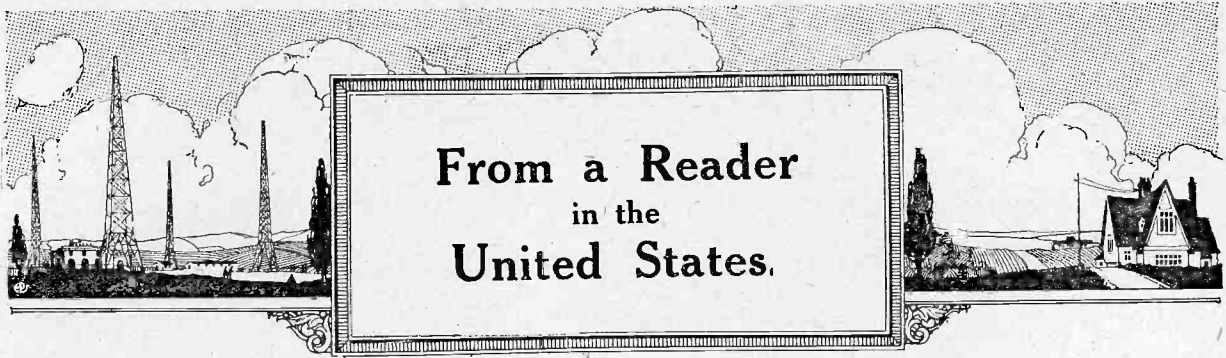

**From a Reader
in the
United States.**

SIR,—Through the kindness of an English friend, I have recently received a copy of the January number of MODERN WIRELESS. It is a most interesting publication, and I wish to express my appreciation of it at this time. Here, in the States, the conditions are very different from those in England and on the Continent, and I find your publication very enlightening as regards English methods of transmitting and receiving.

Simultaneous Broadcasting

During the recent International Transatlantic tests a great amount of interest was shown on this side, and a number of your stations were received. One reason that the stations were not verified more generally lies in the fact that the call letters were not given frequently enough.

The B.B.C.'s chain broadcasting would not be so very popular here, where everyone is looking for distance. The American Telephone and Telegraph do link up stations quite frequently, but only when there is something very important to broadcast, such as the National Conventions. Prize-fights once called for chain broadcasting, but it caused so many people to stay at home that Tex Rickard refuses to allow any further broadcasting of events which he promotes.

The Growth of Radio

Here it is not possible to operate a small crystal or one-valve outfit with any degree of satisfaction. These sets do function in a satisfactory manner when they are near a broadcasting station, but when one lives several hundred miles away from any station, then such a set is of little use.

Clayton is a good illustration of what a small rural town is like. It might interest you to know Clayton's radio history, as I believe that most other towns have very similar ones, and hence it is almost the radio history of the whole of rural America.

There were the usual number of boys who were interested in wireless, and these with their spark coils and crystal receivers made up the group of local wireless experts. Then came the Westinghouse Company with their broadcasting stations KDKA and WJZ, which at that time were very crude when compared with what they are to-day.

Rapid Progress

It was decided to give a concert in the Town Hall, and a receiver was installed, but the concert failed. Station WJZ played special music, and everything was done to make it a success, but failure came swiftly, and in this case silently. This was a decided setback to local enthusiasm, but the few who believed continued to talk radio night and day.

Finally they met with success. A local church was without a pastor, and it was finally arranged that a former pastor would speak from station WHAM in Rochester, New York. A receiver made by the General Electric Co. and an amplifier of Western Electric make were installed, and a loud-speaker set in the pulpit. The church was packed with people from miles around assembled to hear "The Radio." The reception of the hour and a quarter sermon was perfect; every word was understood, and the voice of the speaker recognised by old friends. After that, receivers were installed by many, and to-day finds this little town well equipped with radio receiving apparatus. Most of the sets incorporate five or six valves, and there are two eight-valve super-heterodynes which received English broadcasting every night of the recent tests. The story will give you a good idea of how radio came to the average country community.

Popular Receivers

The squeals of radiating receivers are the greatest pest of the present-day radio fan. No longer do the

amateurs cause trouble. In some localities spark stations owned by the Government do cause trouble, but these are being eliminated and will soon be done away with.

Neutrodyne receivers seem to lead in popularity to-day. With a five-valve set it is easily possible to hear the stations on the Pacific Coast while living on the Atlantic seaboard. The majority of valve sets are equipped with loud-speakers and the sets are no longer playthings. They have a place in every home, and in country places are the chief means of enjoyment.

Advertising by Wireless

Most of our stations are used as advertising mediums, and a great amount of bunk is poured nightly into the air. Every day the quality of transmission is improving, and with it come better programmes. Recently the Victor Talking Machine Company started broadcasting, and now every two weeks the broadcasters may hear some of the finest artists of to-day.

There are, in cities which have broadcasting stations, a great number of small crystal sets; but I rather agree with your Captain Eckersley, who said: "You must at least own a six-valve set in America if you don't wish to be looked down upon like a man who wears an india-rubber collar."

It is a fact that here we go in for multi-valve sets, and this seems to show that the radio public has accepted radio, and it is no longer a plaything, but rather one of the necessary luxuries of modern life. Radio has ceased to be merely interesting; it has become as important as the movies and the newspaper, and the American people are taking it into their homes, not as a wonder, but as a matter of course.

With sincerest best wishes for the year.—Yours truly,

"JACK" P. ROSS.

Clayton, New York.

A Simple Selective Set

By A. D. COWPER, M.Sc.,
Staff Editor.

A simple and efficient single-valve receiver, employing Aperiodic Aerial Coupling and Reinartz Reaction, which can also be used as an ordinary direct-coupled receiver on long waves.

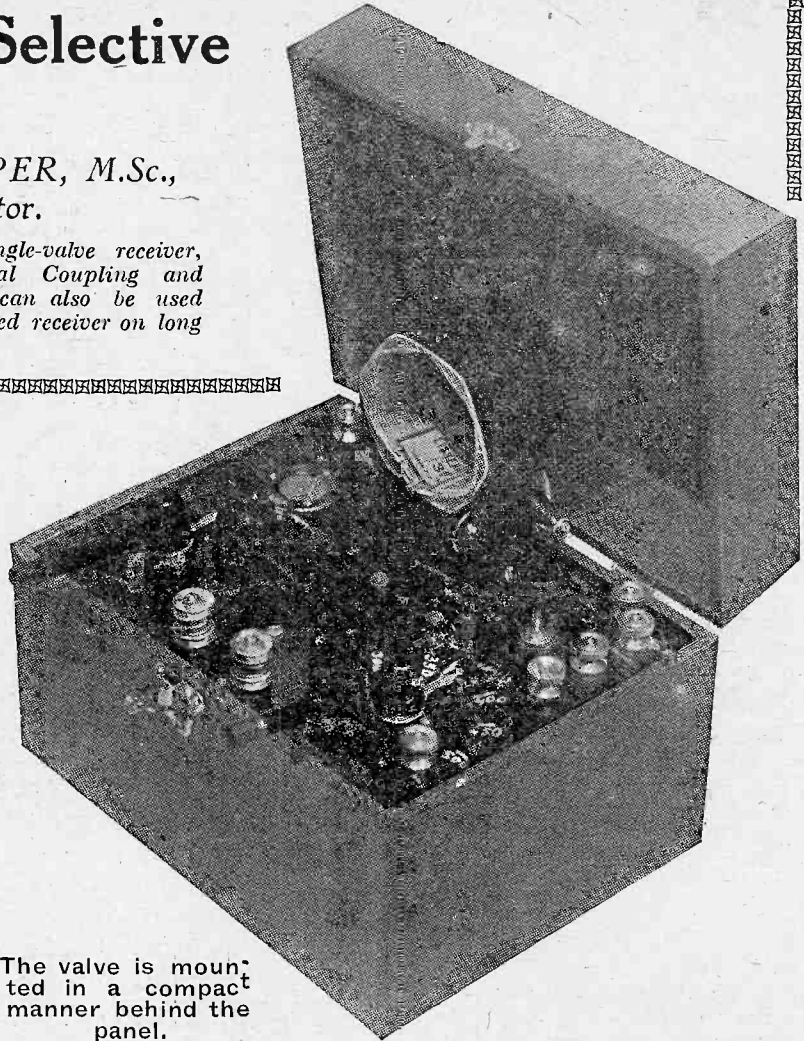

The valve is mounted in a compact manner behind the panel.

THE set to be described here has been designed so that those without much experience of constructional work, and who do not like to undertake the winding and adjustment of the necessary inductances, may still have available the extremely selective device of so-called "semi-aperiodic" coupling, or aerial-tap auto-transformer coupling with but a few turns actually included in the aerial circuit proper, so long and so warmly advocated by the writer for reception of telephony on the short broadcast waves. Combined with this is the Reinartz type of reaction, with a fixed reaction coil fed via a small variable condenser from the plate, a suitable radio-choke being connected in the plate circuit above the 'phones. This device gives a smoothness and ease of reaction-control which is a revelation to those who have struggled with the conventional device of a swinging reaction coil coupled with a fine-wire inductance, itself coupled, in turn, directly to a heavily damped aerial.

For reception of the high-

powered station and long-wave Continental stations (when a good outside aerial is available) ordinary plug-in coils can be substituted for the short-wave coils, and the re-

ceiver is then used as an ordinary direct-coupled receiver, but with the Reinartz type of reaction still in use. With the aerial-load in addition, the reaction control is not then so refined, and there is noticeable the usual effect of reaction-coupling on primary tuning; this is much less troublesome on the flatter-tuned long-wave stations. When a *very small* inside aerial is being used, this arrangement is also to be preferred to the "aperiodic" arrangement, as the latter then involves quite a serious loss of signal-strength on distant stations.

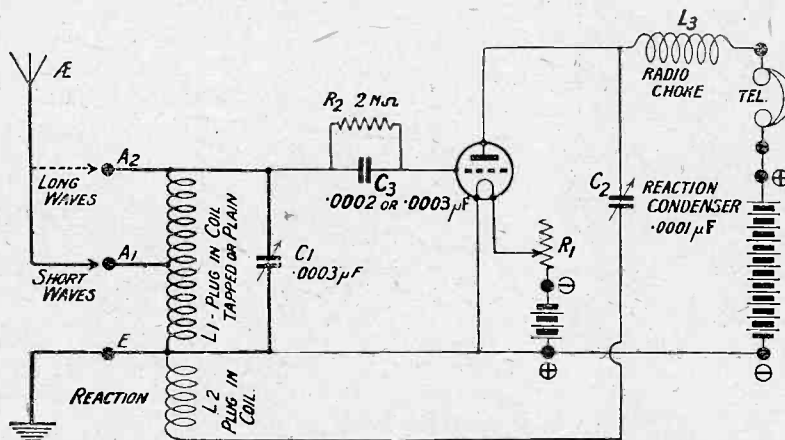

The simplified theoretical circuit diagram.

General Design

The components are all mounted on the back of a panel 6 in. by 8 in. The instrument illustrated was contained in a neat imitation leather covered box with hinged lid, supplied at an extremely moderate price by Messrs. Scientific Supply Stores. The "aperiodic"

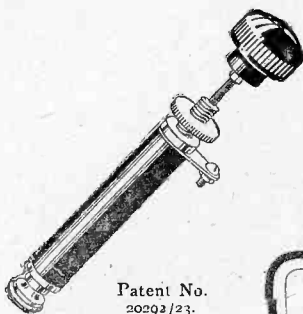

Patent No. 20292/23.

The "BRETWOOD"
Anode Resistance.
Price 3/- Postage 3d.

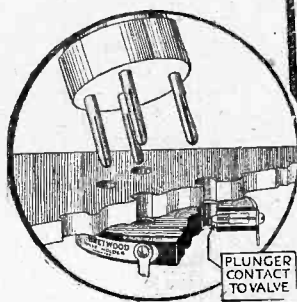

PLUNGER CONTACT TO VALVE

The "BRETWOOD"
Patent Valve Holder.
Price 1/9 Postage 3d.

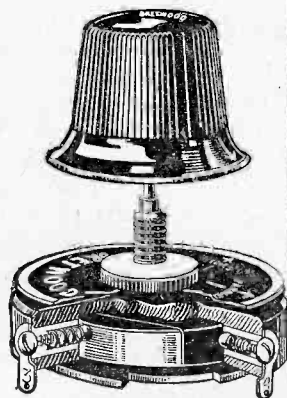

The "BRETWOOD"
Anti-Capacity Switch
Price 5/- Postage 3d.

BRETWOOD, Limited

12-18, London Mews, Maple Street, London, W.

All Bretwood specialities are obtainable from most Wireless Dealers.

Build "Bretwood"
Guaranteed Components
into your set. They are
100 per cent efficient
—that's why they are
successfully used and
recommended every-
where.



The "Bretwood" Anode Resistance.

(Patent No. 20292/23) which gives accurate readings consistently from 10,000 ohms to over 100,000 ohms. This BRETWOOD Component is particularly suited for the ST100 circuit (*Modern Wireless*), the super-sensitive circuit (*Popular Wireless*), and for resistance coupling, etc. It is constructed on the same principles that have made BRETWOOD Components famous, and, of course, it carries the BRETWOOD Guarantee. Price 3/- Postage 3d.

Designed on the same principle as the "BRETWOOD" GRID LEAK mentioned below.

The "Bretwood" Patent Valve Holder.

Fix this efficient component and get maximum results. Positively no leakage or capacity effects. Perfect contact. Can be mounted on front or back of panel. Price 1/9 Postage 3d.

The "Bretwood" Anti-Capacity Switch.

Bretwood Specialities are known throughout the wireless world to be the last word in scientific achievement, and constructors will welcome news of a further Bretwood Product, an Anti-Capacity Switch, the principal features of which include:—Absolute freedom from capacity effects—Perfect Contact—Workmanlike finish and neatness of appearance—Simple single hole fixing and Easy to make wiring connections. Special spring loaded balls in the base make the Bretwood Switch wonderfully smooth in action and ensure clean and perfect electrical contact at all times. It is confidently offered to wireless constructors as the Anti-Capacity Switch *par excellence*, and of course it carries the famous Bretwood Guarantee. Price 5/- Postage 3d.

The "Bretwood" Grid Leak.

The Grid Leak with the N.P.L. Report. Send for copy.

The only accurate variable Grid Leak of watch-like precision and scientific design. If you are not satisfied within 7 days, money will be refunded. Price 3/-, Postage 3d.

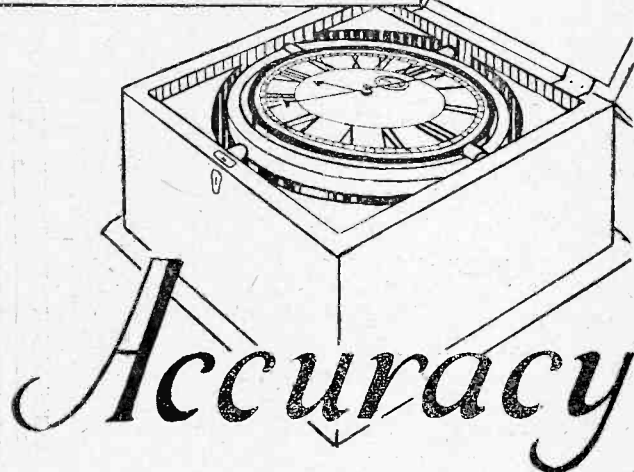
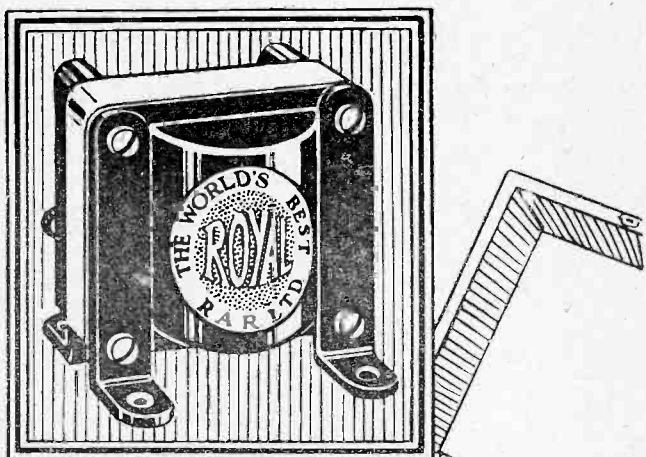

The purchase of an L.F. Transformer upon the well-meaning and appreciative recommendation of a friend is only wise when performance is uniformly and consistently good. The production of L.F. Transformers, with the confidence that these will perform identically, requires scientific manufacturing of the highest order.

Any two chronometers—intricate as these instruments are—register the passage of time identically. What an example of uniform accuracy!

The very close matching of Royal Transformers is an achievement equally scientific. The inductance, resistance, reactance and impedance are as nearly alike as scientific manufacturing methods can produce them.

Thus the incorporation of Royal Transformers into your set is not an enterprise, but rather a confident act; the results you must obtain will equal in volume, purity and richness of tone those which are the pride of many thousands of set builders who build Royal Transformers into every successive receiver they build.

Price £1 0 0

SPECIAL NOTICE.

We have opened a special department handling High-class American Apparatus. We shall be pleased to forward lists describing the following:—

- Tropadyne Kits. Haynes Griffin Products.
- Bremer Tully Low Loss Tuners.
- Cockaday Coils. Apex Vernier Controls.
- Heath Low Loss Condensers. Silver Marshall Apparatus.
- Bradleystats, Leaks and Ohms, and Bradleydensers.

More Items Later.

ROYAL

The Mark of Sovereign Quality

R. A. ROTH & R. MEL, LTD. Manufacturers and Suppliers of all kinds of Wireless Apparatus,
24 & 26, MADDOX STREET, LONDON, W.1.

Telephones: Mayfair 578 and 574

Barclays 875.

In replying to advertisers, use Order Form enclosed.

ELECTRON WIRE

THE PERFECT AERIAL

Not an ordinary Coil of Wire—but an extraordinary Coil of Wire—a special Coil of Wire; a Wire which, known as Electron, the World's Wonder Aerial, has brought immeasurable pleasure to countless wireless enthusiasts. Gone is the trouble of erecting an outside mast with its unsightliness and uncertainty. To-day, the clean *gale-proof* Aerial can be laid over anything, fixed anywhere—in sight or out of sight—with sureness of perfect reception.

A special box

For such a special Aerial it was necessary to have a special Box. For public protection we created a distinctive Box printed in blue, which cannot be mistaken. Thus, if you insist upon Electron, insist also upon genuine Electron in the special Electron Box. The price is 1/8 for 100 feet.



TWENTY pennyworth
OF SHEER HAPPINESS.

A wonderful result

A wonderful result will be obtained even from the most mediocre set, if you use Electron. Give your set a new life with Electron Wire.

READ THESE:

Extract from a letter
March 4th, 1925.
"Wireless Weekly"

"... I erected a number of indoor aerials (of different wires) all exactly the same length, including **Electron Wire**. An independent observer sat with his back to the set, and I changed the aerials about while the observer noted the difference in signal strength. Every time he voted for the **Electron Aerial**.

"This was quite a conclusive test and I can recommend this wire to anyone who wants to fix up an aerial with the minimum of trouble. . . ."

A report, 21/3/25
"Amateur Wireless,"

"... I am writing to let you know the wonderful results I am obtaining with your S.T.41. using an aerial composed of a piece of **Electron Wire** thrown out of my window (my flat being 35ft. high) . . ."

"J. Gandy."
"Port Said, EGYPT."

ON SALE EVERYWHERE

100 ft.	Laid double for loud-speaker and 'phone extensions.	NOW
1/8	300 ft.	IN
Postage 6d.	500 ft.	BOXES
	5/-	8/-

In Boxes Everywhere.

NEW LONDON ELECTRON WORKS, LTD.

Dept. No. 99, (Members of the B.B.C.)

EAST HAM, LONDON, E.6.

Telephone: 1408 East Ham (3 lines).

Telegrams: "Stannum, London."

The Solution

of all your transformer difficulties is one word of seven letters,



POWQUIP



It gives quietly efficient service all the time, is soundly designed and constructed from the very best materials.

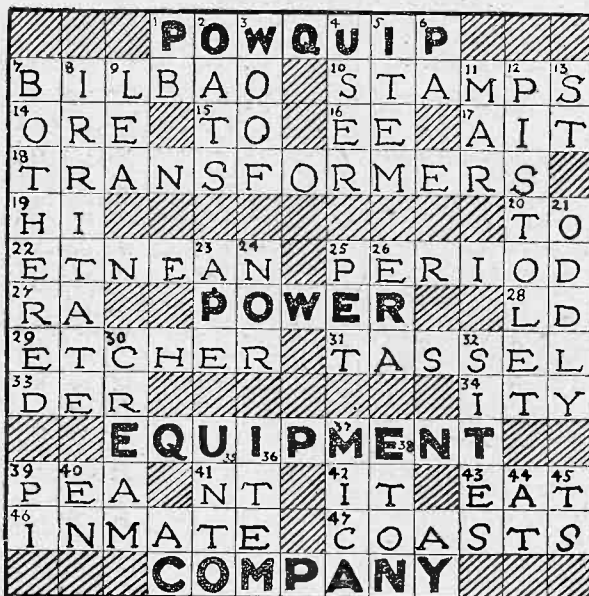

The Twelve Prize Winners are:

- | | |
|---|--|
| M. STIG JOHANSSON,
Storgatan,
Hoganas, Sweden. | R. H. SHERRIFF,
119, Embankment Road,
Prince Rock, Plymouth. |
| S. PARKINSON,
103, Lloyd Street South,
Moss-side, Manchester. | I. B. GRAY,
9, Market Place,
Romford. |
| A. THOM,
The Hill,
Dunlop, Ayrshire. | WILLIAM BAKER,
83, Oliver Street,
Blossbury, Birmingham. |
| J. HEPTOUSTALL,
117, Westminster Road,
Morecambe, Lancs. | J. T. HIXTER,
5, Guernsey Grove,
Horne Hill, S.E. 24. |
| H. T. HAMILTON—
Ardvilla, Victoria Park,
Londonderry. | W. H. DODD,
3, Clissold Park Villas,
Church Street,
Stoke Newington, N. 16. |
| G. F. CANTRILL,
172, Cross Road,
Gt. Heath, Coventry. | E. A. DRAKE, Esq.,
37, Kingsley Road,
Wimbledon, S.W. 19. |

Distortionless reproduction with volume and sweetness of tone are assured, as long as your set lasts, if you fit Powquip Low Frequency Transformers. Every Transformer has each part thoroughly tested before assembly, and the complete instrument is guaranteed by us to give perfect satisfaction for twelve months. (See our guarantee form in every box)

Open Type, 14/6. Shrouded Model, 18/-

The POWER EQUIPMENT COMPANY LIMITED

KINGSBURY WORKS, THE HYDE, HENDON, N.W.9

terminal is actually on the tapped plug-in coil itself, the new No. 60 Lissenagon "X" coil of Messrs. Lissen, Ltd., with two tappings at the sixth and tenth turns respectively, being used. These tappings are brought out to small terminals on bosses arranged on each side of the base or plug-in mount; so that the aerial lead-in wire can be connected directly to either. The A.T.I. coil and the fixed reaction-coil are plugged into fixed holders at the rear of the panel; the two tuning-condenser handles, for A.T.C. and reaction-condenser respectively, are at the front, and the filament resistance control is towards one side of the panel.

Valve Mounting

The valve is carried where it should be in any but a purely experimental receiver—out of harm's way behind the panel. Sufficient clearance is made for the D.E. 5b type of valve, with a large bulb, since wherever possible the writer prefers to use a detector valve of high amplifying power (the D.E. 5b has an M of 20) and generous electron emission. A carbon compression type of filament resistance is suggested, to provide for the use of more than one type of valve, when desired. The small radio-choke used here, which is of a type which will be available from several of the advertisers in this journal, is a very narrow slab-coil of a large number of turns of fine wire, and is mounted directly on the centre terminal of the reaction-condenser in a compact manner.

Radio-Choke

In case this terminal is too short, a small piece of No. 2 or 4 B.A. screwed brass rod can be arranged to carry it in approximately the same position as shown in the figures, the column being secured by back nuts through the ebonite end of the condenser or through the panel itself. A No. 250 or larger plug-in coil can be used in place of the special choke-coil, but is cumbersome. The actual choke shown was that supplied by Messrs. Lissen, Ltd.; it has two terminals and is thin enough to mount directly on the condenser terminal.

Tuning

The A.T.C. must be both of low minimum capacity and of the actual maximum capacity, $0.003\mu\text{F}$, specified, as there is not the large margin which results from the use of excessively large tuning-condensers with several plug-in coils to cover the broadcast belt. Some

types, especially the low-priced metal-ended type with absurdly small insulating bushes, may have so high a minimum capacity that the receiver will not tune down to the relay stations; and a 0.005 "nominal" would be required to reach Aberdeen's wavelength. Those actually incorporated in the receiver shown were the J.B. ebonite-end type and give the desired range. The wavelength scale is almost linear. It is suggested that the usual meaningless degree scales be abandoned, for the short-wave

Components Required

Box or cabinet (to take panel 6 in. by 8 in.).

Panel, 6 in. by 8 in. of $\frac{1}{4}$ in. thickness preferably. (That used was the handsome wood-grain-finish Trolite panel.)

Lissenagon "X" No. 60 double-tapped plug-in coil; a No. 35 plug-in coil, preferably of same make; for 280-500 metres. For higher waves, a set of plug-in coils of any good make.

A $0.003\mu\text{F}$ variable condenser (Jackson Bros.).

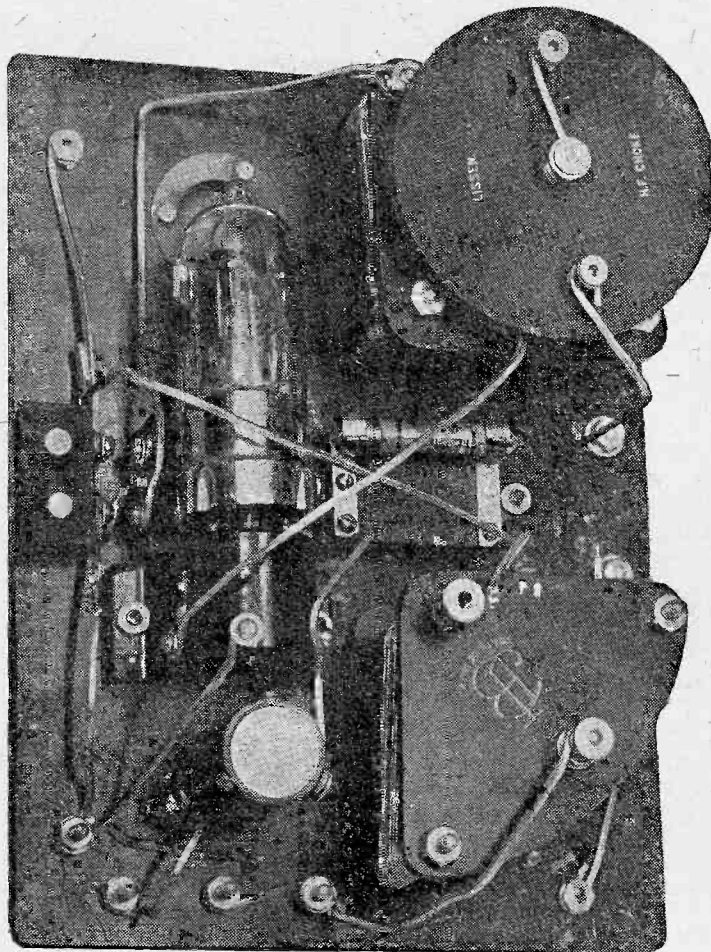

There is sufficient clearance for all types of valves.

range at least, and replaced by "stations" scales, or at least "wavelength" scales. Pointers and short ebonite handles are accordingly used in place of bevel scales; the stations or wavelengths are then marked directly on the panel with a pen and Chinese white, or with black ink on a plain semicircle of ivory (the reverse side of an ordinary 180 degree scale) secured on the panel with Chatterton's compound.

A $0.001\mu\text{F}$ variable condenser (Jackson Bros.).

Radio-choke, narrow disc type. Horizontal back-of-panel valve-holder. ("Aermonic" holder was actually used.)

Narrow carbon compression filament resistance. (L.E.S. Micro-Control was incorporated in the receiver shown and operated well with different types of valves.)

Two fixed coil mount plugs. (The flush mounting type is best.)

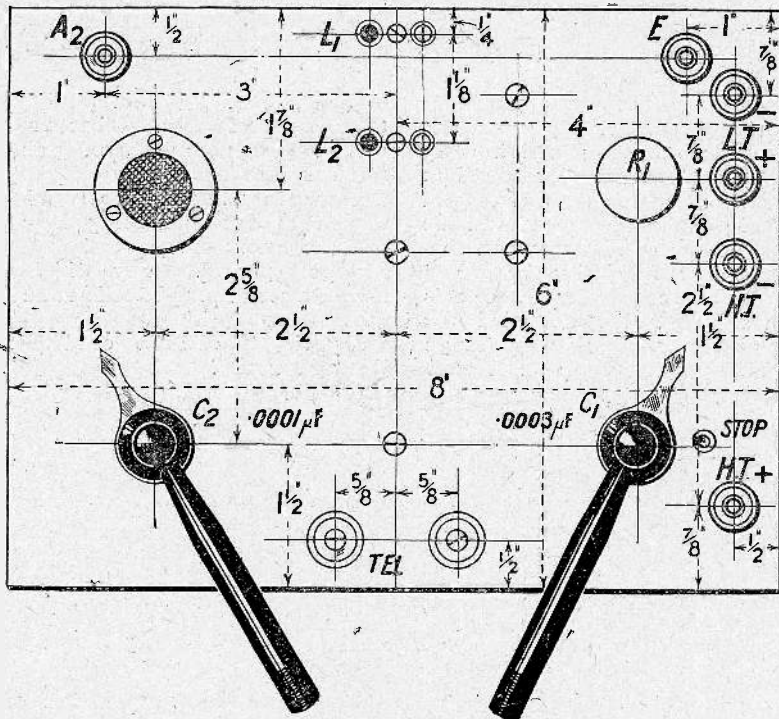

The layout of the front of the panel.

due to overloading the valve together with minimum reaction.

Constructional Details

These are mainly given in the figures and wiring diagram. Those components which are not of the one hole fixing variety are secured by No. 4 B.A. screws with back-nuts through the panel. The coil holder will require four large clearing holes. The window is cut out by drilling a circle of small holes, breaking out the piece thus isolated, and finishing with a round file or small key-hole saw. All wiring is done with bare tinned wire, though actually there are only three soldered joints in the receiver, of which one at least could be avoided, if desired, by putting the wire in question directly on the coil-plug. If any alterations are introduced in the actual arrangement, the point to bear in mind is that the length of the grid-lead in particular, and of any high-frequency leads in general, should be kept to a minimum; and they should be well isolated from other leads and one another.

The wiring of the coil-plugs should be followed carefully, as otherwise reverse reaction will ensue, and negative results will be obtained. In a few cases the reaction-coil itself may have been wired up internally so that it will give reverse reaction even if the other wiring has been done correctly. Hence it is preferable to use the same make of coil for reaction and A.T.I.

The writer believes that the

Valve window (Grafton Electric Co.).

Grid condenser and leak, .0002 to .0003 μF and 2 megohms, of Dubilier or other reliable make. 6 W.O. terminals.

2 Telephone terminals (Gerrard Radio).

Short extension handles, and pointers.

No. 4 B.A. screws and nuts; No. 16 gauge or square bus-bar wire, tinned.

A set of Radio Press Panel Transfers.

Value of H.T.

With the D.E. 5b valve, a 6 volt accumulator and the full 60 volts or so of the H.T. battery may be required, but with a soft Dutch valve a 4 volt accumulator is generally required, and the H.T. value is very critical. One experimented with gave excellent results with just 19 volts H.T. Ordinary R valves require usually a 4 or 6 volt accumulator and 50 volts H.T.; for other types the makers' instructions should be followed, and the H.T. adjusted at the smallest value which will give easy, steady oscillation over the whole scale when trying for distant stations. The principal point to notice is the necessity for careful adjustment of filament and H.T. in order to eliminate all "oscillation hysteresis" or backlash; these should be adjusted, by trial, so

that the valve glides imperceptibly into and out of oscillation without any "pop." It is possible to accomplish this with a lightly coupled aerial and Reinartz reaction, and it is the whole secret of efficient reception with a valve. On the loud local station this does not apply so much; a bright filament and maximum H.T. may be necessary then to avoid harshness

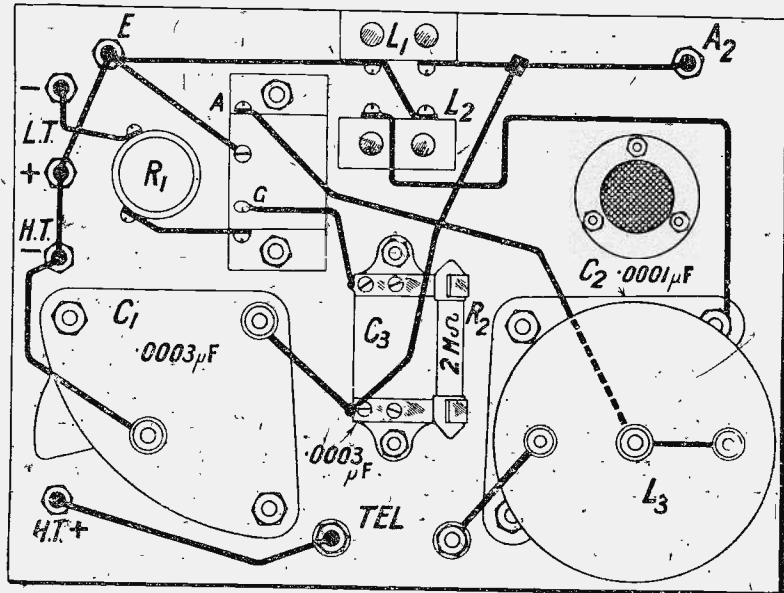

The wiring may be easily followed from the diagram. The dotted line is the connection to the centre spindle of the reaction-condenser C₂.

Shipton

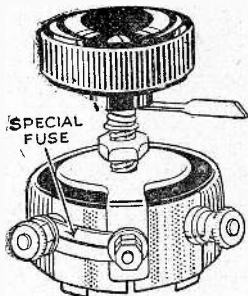

Shipton Strip Rheostats.

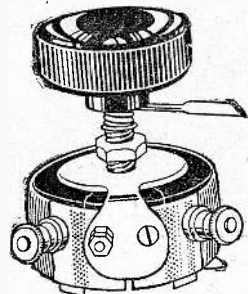

Shipton Potentiometer.

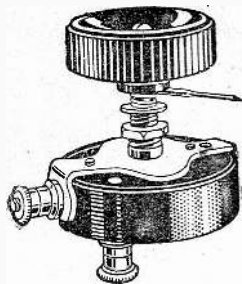

Shipton Gridleak.

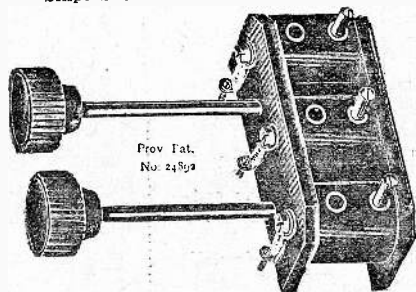

Shipton Coil Holder.

SHIPTON GIRDER COILS.
Double basket wound. Enamelled wire. A really highly efficient coil.

Size	1	2	3	4	5	4d.	5d.	6d.	7d.	8d.	Size	6	7	8	9	10	600-1,000	900-1,350	1,200-1,800	1,500-2,600	2,000-3,000	9d.	10d.	1/-	1/2	1/4
	100-250	200-350	300-450	400-550	500-750	4d.	5d.	6d.	7d.	8d.	6	7	8	9	10		600-1,000	900-1,350	1,200-1,800	1,500-2,600	2,000-3,000	9d.	10d.	1/-	1/2	1/4

Double cotton covered coil 2d. extra.

You can obtain Shipton Products from your usual dealer. If he cannot supply kindly send his name and address when sending direct.

Build Shipton Products into your Sets and you build efficiently. You will obtain results of which experts would be proud. Shipton apparatus is designed with a practical sympathy with the experimenter's needs. Ask your dealer for Shipton Products and gain utmost efficiency and complete satisfaction.

SHIPTON NEW TYPE STRIP RHEOSTATS. THE MOST PERFECT RHEOSTAT YET INTRODUCED.—A specially designed spindle gives one-hole fixing and incorporates a tension spring which ensures perfect electrical contact at all times; terminal connections are provided. The 7 ohm. Model is fitted with a replaceable fuse, which little device may save you the cost of an expensive valve. In operation they are noise free. One-hole fixing. As used in various Radio Press Receivers.

SHIPTON New Type STRIP RHEOSTAT 7 ohm (with fuse)	3/-
SHIPTON New Type STRIP RHEOSTAT 30 ohm	3/-
SHIPTON New Type STRIP RHEOSTAT 60 ohms	3/-

SHIPTON POTENTIOMETER.
Essential for precise control of any H.F. Receiver. Makes Multi-H.F. work a pleasure. One hole fixing.
60 ohms 4/6

THE SHIPTON NEW TYPE VARIABLE GRID LEAK.—Here is another SHIPTON efficient unit. Mechanically perfect and thoroughly tested by experts to secure maximum and uniform efficiency.
Silent in operation. Constant under different settings. Can be calibrated accurately. Reliable under all conditions.

FARADAY HOUSE LABORATORY TEST REPORT.

No. T/252/H.
... The gridleak submitted was tested for resistance at various positions of its handle, and the resistances varied continuously from 0.5 megohms to 6.5 megohms.
Price 3/-

SHIPTON NEW TYPE VERNIER COIL HOLDER.

Gives perfect adjustment. Solid Ebonite. No loose connections. No backlash. For Panel Mounting.

2-way, price	4/-
3-way, price	7/6
Nickel-plated, 2-way, price	4/6
3-way, price	8/-

E. SHIPTON & CO., LTD.

37, TOTHILL STREET, — WESTMINSTER, S.W. 1.
Telephone: Victoria 3171. Telegrams: "Rentfones, Parl."
Also at 14, KING STREET, COVENT GARDEN, W.C. 2.
Trade Enquiries Invited.

3 or 4 Valve Portable Wireless Case

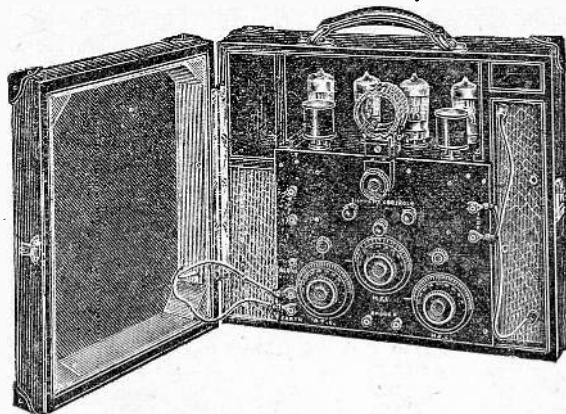

Beautifully finished, portable case, covered with black Rexine, lined with velvet, closed box for instantly making up 60 volt H.T. battery with pocket lamps, and provision for filament battery and headphones, with frame aerial, all self-contained, 16 1/2 inches by 14 inches by 6 inches, overall measurement. Cabinet supplied with panel and frame aerial wound for 500 or 1,600.

PRICE:—Case only, black, first class finish .. £1 15s.
Cheaper quality in brown £1 10s.

Also sold made up ready for use. Has a complete receiver guaranteed to possess maximum range of reception both with and without aerial. First-class components only used.

PRICE, complete with L.T. and H.T. headphones, etc., less valves and royalties.
3 Valve £12 12s.
4 Valve £14 14s.

EAGLE "ECHO" CRYSTAL SET

A most efficient crystal receiver with Variometer tuning and provision for extra inductance for 5XX. First-class dust-proof detector with ebonite ends. We have unsolicited testimonials stating perfect results at 40 miles from Relay Stations. All parts are nickel plated and contained in a beautifully finished Mahogany Cabinet.

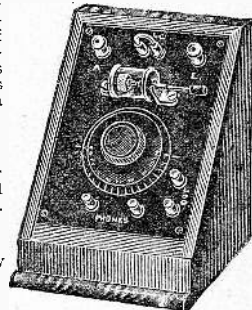

PRICE .. 16s. 6d.

Same design but with Variable Condenser Tuning with coils for London and Chelmsford; most efficient tuning obtainable.

PRICE .. 22s. 6d.

AMPLIFIERS to match with first quality Transformer.

PRICE .. 22s. 6d.

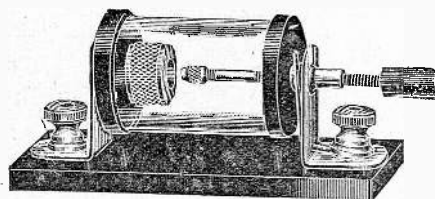

Cheapest Micro detector full adjustment, nickel plated with ebonite ends.

PRICE .. 2s. 3d.
1/2 opal—2s. 6d.

THE VERY THING YOU REQUIRE FOR BUILDING YOUR SET. ELECTRIC SOLDERING IRON.

The cheapest and best ever put on the market with all parts interchangeable, full guarantee. Spares always in stock.
Medium size .. 12s. 6d.
Large size .. 17s. 6d.
(110v. to 240v. low consumption).

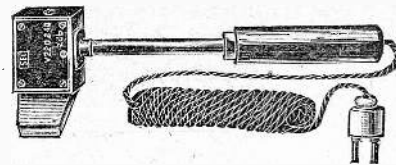

Wireless components and cabinets of all descriptions in stock, or made to order.
TRADE SUPPLIED. EXPORT A SPECIALITY.

The Eagle Electrical Mfg. Co., Ltd., 32, CHARLOTTE STREET, LONDON, W.1.

Telephone: Museum 8382.

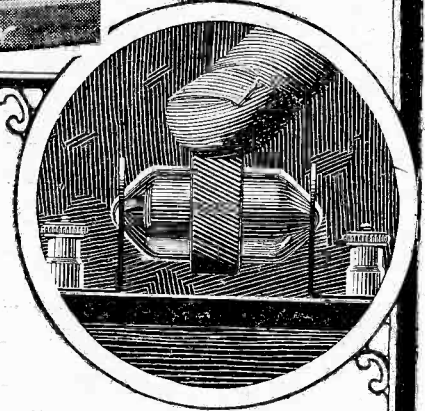
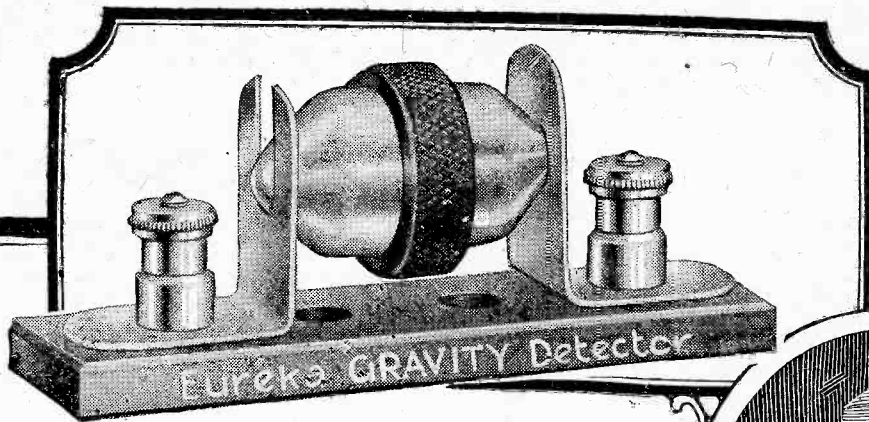

Out of the welter of exaggerated claims and mis-statements comes the new Gravity Detector—

IF the 1925 Radio Season is famous for nothing else it will be noteworthy for the heavy crop of new crystal detectors. Large and small—cheap and expensive—permanent, semi-permanent or with cat-whisker—every type is represented. But one stands out from the crowd. One is so unique in its principles that it cannot fail to attract attention. **The Gravity Detector.**

The Eureka Gravity utilises all the sensitiveness of the catwhisker Detector but with none of its disadvantages. Its principle is just this: The crystal is held in a cup within the centre of the cartridge. Around the periphery of the case is placed a row of catwhisker points, each one of which is weighted at the head. When the Gravity is rotated these points are caused to drop, one by one, to make contact with the Crystal. Thus it is only necessary to give the Detector a twist until the loudest signals are heard.

No factory-sealed permanent Detector can ever hope to compare with the Eureka Gravity because the user can utilise any favourite piece of crystal known to be absolutely sensitive.

Besides, no crystal lasts for ever—its sensitiveness is bound to fall off in time. In any case, the present immense popularity of catwhisker contact is proof positive that any double-crystal combination is of

little value under present-day conditions.

To change the crystal in the Gravity is but a moment's work. Just lift it from the spring clips, separate the two halves, lift out the old crystal and drop in a new piece, and the job is done. Quicker in fact than describing it. And the crystal is protected against dust, finging and light.

No matter which type of Set you are using the Gravity will improve it. If it is a Reflex it will stabilise it and yield wonderful tone. Experience has proved that half the trouble in reflex Sets is due to the incorrect pressure of the catwhisker. In the Gravity this is done for you automatically. We have calculated the pressure at which the contact should be made—no more, no less.

Get your Dealer to show you one of these handsome Gravity Detectors to-day—the fact that it is a product of the manufacturers of the Eureka Transformer is a sure guarantee of its excellence.

Six advantages you get with no other Detector.

1. The Crystal is firmly held in a spring cup and the moving points fall to make contact with it as the holder is rotated.
2. When the Gravity Detector is in use the Crystal is fully enclosed and protected from dirt.
3. The Gravity Detector can be reloaded with a new crystal in a moment. Nothing to unscrew or solder.
4. The slightest turn of the Detector automatically brings into use a new spot on the crystal and a new contact point.
5. Nothing to wear out—the Gravity Detector will last a lifetime.
6. Stout plated spring clips are supplied and the base can be removed for fitting the Detector direct to the panel.

Complete with Crystal

6/6

Portable Utilities Co., Ltd.,
Makers of the Eureka Transformer
Fisher Street, London, W.C.1.

And from all Dealers

EUREKA GRAVITY Detector

Lissenagon tapped coil is made with the tappings towards the end connected to the male plug connection; the "earth" end is thus the socket side of the coil base, and the receiver is wired accordingly, with "plug" of the A.T.I. mount connected to earth. The reaction-coil mount is arranged the same way round, but the connection is crossed as shown.

Operation

Beginners are advised to insert the valve first with the H.T. battery wholly disconnected, and

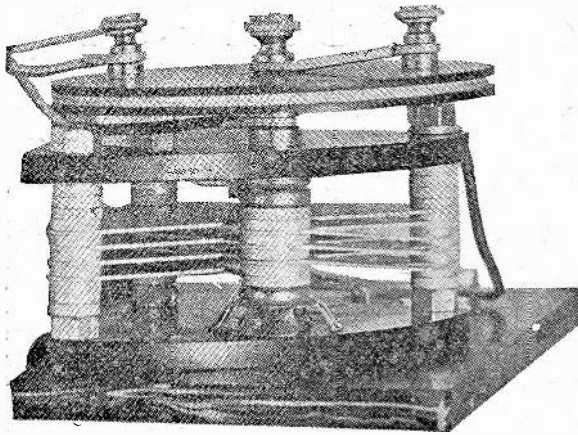

A close-up view showing the method of mounting the radio-choke.

to ascertain whether it lights up properly, this before doing anything else. Then, with the 'phones on, the positive plug should be inserted in the first tapping of the H.T. battery, and the one 'phone lead touched intermittently on its terminal, to note if plate-current is flowing. When all is well, the H.T. can be cautiously increased to maximum value, with bright filament, when a loud bang should be heard on disconnecting the 'phones momentarily. On turning the reaction handle towards maximum ("all in") at one point a soft "plop" should be heard when the Nos. 60 tapped and 35 reaction have been duly inserted in place. This should then be heard both on touching and on withdrawing the finger from the aerial terminal. The receiver is then oscillating. This should all be tried without an aerial.

With reaction at minimum, the aerial can then be attached to the No. 10 tapping on the tapped No. 60 coil. While the local transmission is available—it is useless to look for distant stations until some experience has been gained, as it is easy enough to miss the former entirely with this selective receiver—the tuning handle (A.T.C.)

should be slowly moved in the range where your station might be expected. With a coil of definite inductance, and a tuning-condenser of known size and range, the element of uncertainty is largely eliminated from the tuning with this type of coupling. By slowly increasing the reaction, the station should finally be heard, below the "plop" point, which indicates oscillation when oscillation hysteresis is still present. The tuning should be left at this point, and the reaction adjusted to give maximum clear signals, without the hoarse speech and jangled out-of-tune effect with music which spells oscillation. There should be no wai when the tuning is slightly altered. Finally, by small adjustments of tuning, reaction, filament and H.T., the best result for that station is obtained.

Reception of Chelmsford

With the larger coils, as direct coupling is used, less precise information is available, and the tuning points must

be found by trial, different aeriols implying either the No. 150 or the 200 coil for 5XX, with the smallest reaction-coil which will give oscillation with this in use. Both sizes should be tried. On a small indoor aerial the No. 200 coil and nearly all the tuning capacity were required, but a No. 60 reaction sufficed. On a large outdoor one with long lead-in the No. 150 with 200 reaction-coil may be required. Some types of valve with a low M and small filament emission will require a size larger reaction-coil in every case. The writer has tried a large number of valves of all types in this receiver, ranging from the .06 type to small power valves, and except for this point no trouble was experienced, with proper H.T. and filament temperature. Excellent results were obtained on a small indoor aerial with the Dextraudion (filament 0.1 ampere, 1 volt) D.E. valve run from a single small bell-battery with some 50-60 volts H.T. The ordinary "pea-nut" type and the 2 volt 0.5 ampere type of D.E. also operated well, with the usual reaction coils.

Test Report

In this connection the very

pertinent remarks of Mr. P. W. Harris in recent issues of the *Wireless Constructor* and *Wireless Weekly* might well be quoted as to the different range, etc., to be expected from a given receiver under different operating conditions. This set was designed for home construction rather than for extreme D.X. work in the hands of experts. Actually, on a moderate outdoor country aerial in a good position for reception, and under favourable conditions, all the B.B.C. main stations and relays, mutual heterodyne excepting, have been read repeatedly on this set; a dozen Continental stations at least; and one or two American stations (KDKA and WBZ); whilst the local stations, 2LO and 5XX, each at 35 miles, came in at moderate loud-speaker strength, the latter being the louder. A child of six, with a few simple instructions, was able to tune in London at moderate loud-speaker strength, with proper adjustment of reaction to give good signals without oscillation, within one minute and with no previous experience. In this condition the application of the moistened fingers across aerial and earth terminals did not silence 2LO in the loud-speaker. A D.E. 5b valve was used, with about 60 volts H.T. On the earth-lead alone, or on a short length of No. 20 as indoor aerial, beneath a corrugated iron roof, London was still clear on the 'phones. With a temporary aerial consisting of a short length of Electron aerial wire thrown into the branches of a small apple tree, away from other aeriols, and with the instrument and its batteries standing on wet grass but with no

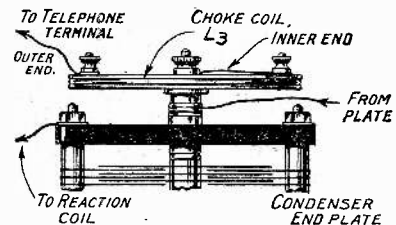

A sketch indicating the connections to the reaction-condenser and radio-choke.

direct earth connection, London (35 miles) was readily tuned in on the 'phones, and at least one other wave was heard, probably that of Birmingham.

The effective range of the receiver will be greatly increased by the addition of a silent stage of L.F. amplification, since the limiting factor is the ratio of casual local noises to signals,



"Macondo" Pneumatic Ear Pads

We have received from Messrs. McLeod and McLeod samples of the "Macondo" pneumatic ear pads for use on the ear-pieces of existing head-sets. At the present stage of advancement of the radio art, when very many listeners are still compelled to wear head-phones for considerable periods in order to listen to the programmes, any device is welcome which will in some measure reduce the extreme discomfort, amounting at times,

after continuous wear for an hour or more to little short of torture, experienced by many when their heads are clamped closely in the jaws of the average head-set, particularly when the ear-pieces are of the small type. These pneumatic ear-pads proved, on extended trial, to alleviate this discomfort to a large extent, and made possible the wearing of the head-phones for longer periods without the unpleasant after-effects often experienced. They consist of a small annular inflated rubber cushion,

about 2 1/2 in. diameter, with a corrugated surface of thin rubber and with a rubber flange at the back to fit over the ear-piece. They could be fitted, on trial, over even the very large type of ear-piece used on certain types of head-phones. Incidentally, these close-fitting pneumatic pads excluded external noises to an unusual degree, so that for crystal reception considerable improvement may be noticed from this point alone; but for extreme D.X. work the slight rattle noticed in the rubber from movements of

—AVOID— OBTAIN
DISTORTION SELECTIVITY
INSIST ON HAVING

TANGENT FITMENTS

"TANGENT" TUNING COILS.
Guaranteed for Low Self Capacity by the N.P.L.

"TANGENT" HEAD PHONES.
The Head Phone with a tradition.

"TANGENT" LOUDSPEAKERS
"Concert Model," "Tangent Tall Boy" and "Baby Tangent."

"TANGENT" L.F. TRANSFORMERS
Large and Small.

"TANGENT DISCOL" H.F. "TRANSFORMERS."

All Wavelengths from 80 to 4,000.

Obtainable from all good Dealers, but in case of difficulty write us.

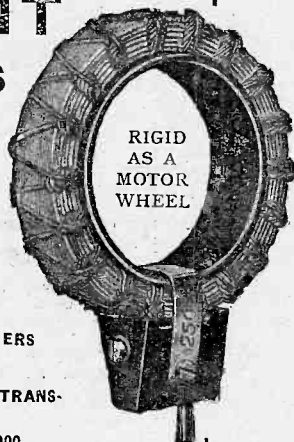

Selectivity and Sharp Tuning depend on the Tuning Coils. Efficiency and Purity on the Components.

GENT & CO. LTD. Est. 1872.
"Faraday Works," LEICESTER.

London: 25, Victoria Street, S.W.1.
Newcastle-on-Tyne: "Tangent House," Blackett Street.

Mechanics!

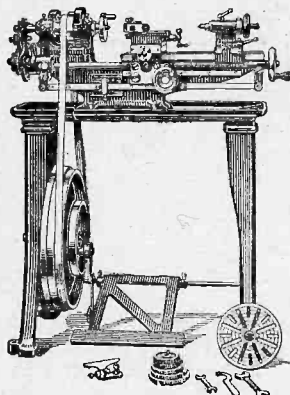

Why not get the best out of yourself and your tools?

Your time and patience will be largely wasted if you have only makeshift tools. With a first-class lathe you can always do fine work. Why not invest in a tool that will be really worth while? You'll never regret it.

The best tools are the cheapest!

For all-round utility and adaptability
DRUMMOND LATHES

are the finest tools for both amateur and professional. They are complete, supplied in all forms of drive and equipped with every useful device. They are guaranteed. Every Drummond tool has over 22 years of machine design behind it. For wireless, model making, car and motor-cycle repairs, etc., they are ideal. Write, or send the coupon.

To DRUMMOND BROS., Ltd., Reid Hill, Guildford.
Please send me (free) lists of your 3 1/2 in. and 4 in. Lathes.

Name

Address

Post unsealed for 1d. Please write distinctly.

the head, etc., might nullify this advantage. A point that should be noticed in practical use is that the perspiration cannot escape when these are worn, and therefore condenses in quite a noticeable degree on the diaphragm and in the receiver. Particularly with a valve receiver this should receive attention, on account of possible insulation deterioration, and with diaphragms which are liable to rust, the ear-pieces should be removed at intervals and dried out.

With this proviso, we can certainly recommend these aids to comfort in reception.

"Goltone" Coil-Holder

Messrs. Ward and Goldstone, Ltd., have sent for test a sample of their three coil holder, the "Goltone" Micrometer Regulating Holder. This is for mounting either on the front of a panel or on the side of a cabinet, and is built up on a moulded base which is in one piece with the sides of the instrument, between which the coil-plugs are arranged. The base is to be secured by small screws through the rim of it; an open space is left through which the ordinary flex connections can be carried to small terminal screws on the coil holder itself. The fine adjustment device consists of

a long spindle with a longitudinal micrometer adjustment, a knob at the end of which bears against a contact piece attached to the moving coil holder. The latter is held up by a spring, which eliminates back-lash. On trial the mechanism operated smoothly, and gave close control over coupling.

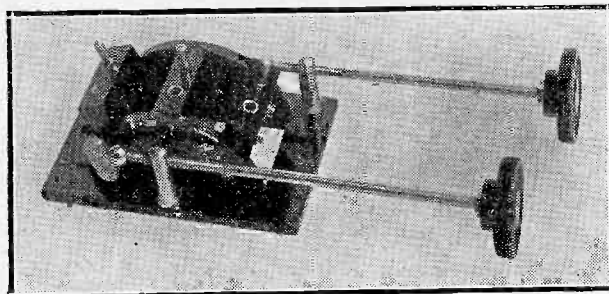

The "Goltone" three coil holder.

It was found that the springs were strong enough to handle the usual sizes of coils, but the holder should be used in a vertical position if very large coils are in use. The insulation resistance was excellent.

"Radiax" High-Frequency Couplings

Messrs. Radiax, Ltd., have sent samples of various devices for use in H.F. amplification coupling.

Mushroom types of plug-in H.F. transformers were submitted in the sizes for the ordinary broadcast range; and for the high-power station and above. These on test gave a range up to the point indicated, 600 and 116 kilocycles (500 and 2,600 metres wavelength) respectively, with less than .00025 μ F

parallel tuning capacity. To reach the highest frequencies of 1,000 and 200 kilocycles (300 and 1,500 metres wavelength) quoted, required, it was found, both a very low minimum in the tuning condenser and small casual capacities in

the valve-panel used.

The tuned-anode units, consisting of a very similar small mushroom type of fitting, but with two legs only, to fit in an ordinary 4-pin holder, showed similar tuning range and characteristics on test.

A larger tapped inductance for tuned anode reactance capacity coupling was mounted on the usual 4-pin base, and had incorporated

Be Fair

—to your Receiving Set. Give it the opportunity it deserves, to show you what it can really do.

There are undreamed of "DX" possibilities in every Receiver—in *your* Receiver—if you will only provide a reproducer that won't hide the little signals it receives, so that you don't know that they *have* been received,

Any Receiving Set that is worth attaching to an aerial is worth treating fairly—is worthy of the best headphones—is worthy of "General Radiophones,"

Try them and see!



Weigh only 7 ozs. with cords.

Issued by the Publicity Department
of the General Radio Company, Ltd.,
Radio House, 235, Regent Street, W.1.

20/-

in it the necessary anode-grid connection. A small 6-point selector switch (with short-circuiting arrangement to reduce effects of dead-end turns) gave an effective range of about 100 to 1,500 kilocycles (200 to 3,000 metres wavelength) on test.

In each case no trouble was experienced with instability, using ordinary parallel tuning on a direct-coupled aerial. Amplification, as compared with a single-valve with properly controlled reaction, was not conspicuous; and the selectivity, when using critical reaction, was notably less than with the single detector-valve alone.

Reaction units were also submitted for use with these devices. One type had a small coil pivoted on a fitting which plugs into a central hole in the transformer or anode coil, being controlled by a short insulated handle. On trial, with good standard R valves and 50 volts H.T., this sufficed to give oscillation over the whole range. The higher range coil gave, on trial, good results with the tuned-anode unit, but produced uncontrollable self-oscillation with the corresponding transformer even when quite isolated. Unfortunately, one terminal on the short-wave reaction unit was

so tightly screwed up that the whole twisted out and broke one wire connection when attempt was made to unscrew it, so that this could not be tested.

The insulation resistance in the transformer units proved excellent on trial.

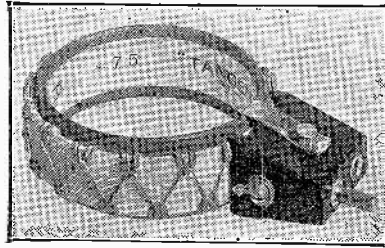

A robust coil, the "Tangent."

"Tangent" Coils

A set of tuning inductances, Nos. 25 to 75, covering the usual short broadcast wavelength range, has been submitted for test by Messrs. Gent and Co., Ltd. These are extremely robust coils wound as simple short solenoids on a ring former, 3 in. diameter, and secured by a crossed lacing of fine cord. The Nos. 25 and 35 are single-layer, of fairly fine wire and

1/2 in. to 3/4 in. wide; the other two had a double layer, separated by the fine cord mesh. The usual plug-in fitting is provided, very securely fastened on by a brass strap.

Measured on a basic capacity of .0003 μ F plus casual panel capacities, corresponding to a P.M.G. aerial under working conditions, the wavelength range was from 240 to 370 metres for the No. 25, and from 300 to 460 metres for the No. 35, with a .0005 μ F (actual) tuning condenser. The No. 50 gave 480 to 740 metres, and the No. 75, 660 to 980 metres tuning range under the same conditions. With a .001 μ F (actual) tuning capacity the No. 35 gave up to 575 metres, the No. 50 to 900, and the No. 75 to 1,250 metres, thus covering the range from 240 to 1,250 metres with adequate overlap. Free oscillation was obtained over this range under normal working conditions, the reaction-coupling required being noticeably less than with some plug-in coils, indicating a moderate H.F. resistance and comparatively small dielectric losses. Signal strength and selectivity were about what one would expect with an average fairly fine-wire plug-in coil.

CUT OUT THE "CRACKLING."
PUT A LARGE
"OCTOPUS"
Mansbridge Condenser

ACROSS YOUR H.T. BATTERY, SMOOTH OUT THE JERKS AND GET RID OF NOISES.

The Best

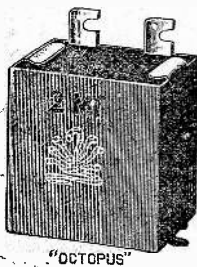

By Test

	s.	d.
EVERYTHING	.01	2 4
A GOOD	.05	2 4
CONDENSER	.25	3 0
CAN BE.	.5	3 4
	1 MF.	3 10
	2 MF.	4 8

All capacities same size face, i.e., 2-in. by 1 1/2-in.

ACCURATE, NOISELESS, PERMANENT,
ABSOLUTELY RELIABLE, TESTED AT 350 VOLTS D.C.
BEWARE IMITATIONS, LOOK FOR THE TRADE MARK.

SETS OF PARTS FOR ANY AND EVERY CIRCUIT.

WE SPECIALISE IN GIVING THE BEST KNOWN VALUE AND SERVICE
WRITE YOUR ACTUAL NEEDS. GIVE US YOUR IDEAS AND LET US QUOTE.

EVERYTHING FOR WIRELESS AT ROCK-BOTTOM PRICES.

"RADIO STOCKS" (B. HAINE, Proprietor),
RADIO HOUSE, NEWMAN STREET, OXFORD ST., LONDON, W.1.
PHONE: MUSEUM 3205.

THE
"Perfect" Vernier Coil-Holder

FOR BASKET COILS

New and Come to Stay

EASILY THE BEST ON THE MARKET

SAMPLE ON 48 HOURS' APPROVAL 6/6 PLUS
6d. POSTAGE, OR COMPLETE OUTFIT OF

COIL HOLDER and COILS
(SEVEN IN ALL)

For All British Stations

POST FREE 12/6.

The Best Tuner Obtainable.
Results Will Surprise You.

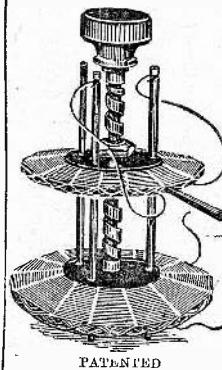

Micrometer Tuning.
Dead Close Coupling.
Parallel Coupling.
Coils Changed Instantly
No Coil Mounts.
No Hand Capacity.

No Loose Connections.
No "Fiddling" about.
Strong and Handsome.
Needs Small Space.
Extremely Simple to
Fix and Use.

WRITE FOR LISTS,
Wholesale and Retail.

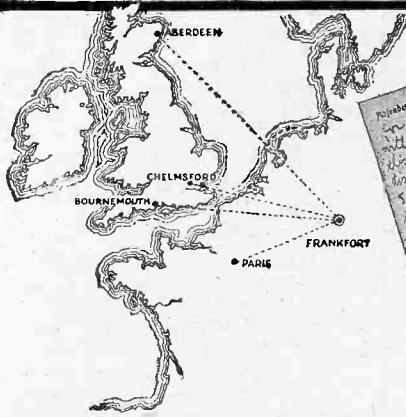

The Postcard, reproduced here, reads as follows:-

"I bought one of your Crystals here on Saturday last, and would like to tell you of my results. Frankfort o/M., one-and-a-half miles off, on the L. Speaker, Radio-Paris and 5 X X loud on one pair of 'phones, and still easily readable on five pairs. Sunday morning I got the concert from Koenigs-wusterhausen on 2,800m., and after dinner 2-3 W.E. time, Radio-Paris. Monday evening I tuned in Bournemouth, 5 X X, R-Paris, some other stations, which I did not wait to identify, and finally I got Aberdeen perfectly clear. I think for pure Crystal reception, without any amplification, this is nearly a record, the distance being over 1,200 Km. 5 X X and R-Paris I can tune in while Frankfort is transmitting (with a wave-catcher). My aerial is non plus ultra. With hearty congratulations on the excellence of your fabric, I am,

(Signed) HENRY HERZ-MILLS. Wilhelmstrasse, 20, Frankfort o/M.

An endorsement from Germany

Aberdeen, Chelmsford, Radio-Paris, Bournemouth and Aberdeen—received at Frankfort, Germany, on a Neutron Crystal, without amplifiers.

Not only in this country, but also abroad, the fame of Neutron Crystals is spreading. Already widely known here as the crystal that breaks records for "distance," Neutron is being widely used by the amateurs of Germany, France, Spain and the British Colonies, who find it the most reliable, the most sensitive, and the Crvstal that gives greatest volume—and distance.



Concert Tested & Guaranteed Radio Crystal

Stocked by the Best Radio Dealers. Packed in tin, with silver cats-whisker. Insist on Neutron, in the Black and Yellow tin. If unable to obtain, send 1/6 with dealer's name, and this wonderful crystal will be mailed by return.

1/6

Produced by NEUTRON, LTD., Sicilian House, London, W.C.1. Phone: Museum 2677.

Sole distributors: V. ZEITLIN & SONS, 144, Theobald's Road, London, W.C.1. Phones: Museum 3795 & 6841.

"ELLA" BATTERY CHARGERS

They work from a lampholder

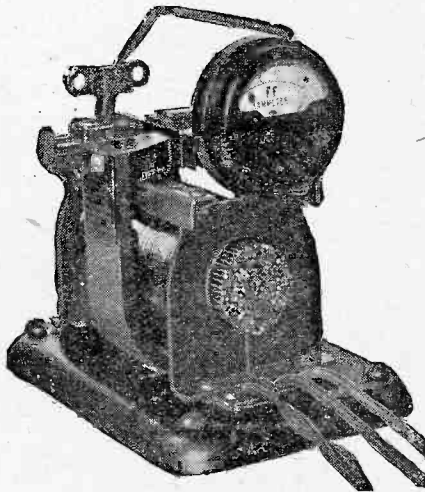

A.C. Model.

Output 6 amps. 9 volts. Complete with Pole Indicating Ammeter and all connecting leads and adapter. To standard voltages and frequencies up to 220 volts. £6 6 0

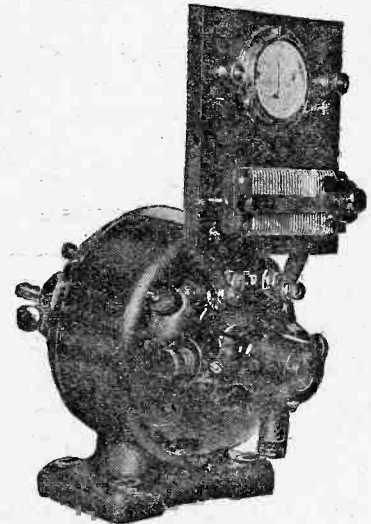

D.C. Model.

Output 5 amps. 9 volts. Machine only £5 12s. 6d. With Switchboard and Pole Indicating Ammeter and Regulating Resistance as illustrated - £6 15 0

Other voltages and frequencies £1 extra. BATTERIES charged at home have much longer life and give better service than when charged outside. "ELLA" Battery chargers save their cost many times over. Write to Dept. Dept. "A" for descriptive leaflet. Trade supplied.

LIONEL ROBINSON & CO. 3a, Staple Inn, London, W.C.2.

'Phone: Holborn 6323 (Two Lines).

In replying to advertisers, use Order Form enclosed.

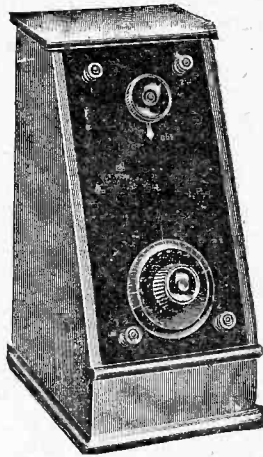

A.B.C. WAVETRAPH complete and ready for use, £2 17 6.

Complete set of components for constructing above, exactly as described in Envelope No. 6. £2. Send for list.

Will eliminate your local station at 1 mile range.

Construct a Radio Press Set and save pounds.

	£	s.	d.
S.T.100	6	19	0
Four Valve Family	9	0	0
Simplicity 3	4	13	2
Transatlantic 4	11	0	0
Transatlantic 5	11	11	0
Anglo American 6	18	4	6
Onni	11	11	0

RADIO PRESS ENVELOPES.
Post free.

No. 1. S.T.100	1/9
No. 2. 4 Valve Family	2/9
No. 3. Simplicity 3	2/9
No. 4. All Concert-de-Luxe	2/9
No. 5. Onni	2/9
No. 6. A.B.C. Wave Trap	1/9
No. 7. 2-Valve Amplifier-de-Luxe	1/9
No. 8. 1-Valve Reflex	1/9
No. 9. Efficient Single Valve	1/9
Radio Press Transfers	8d.

EBONITE COIL FORMER (CROSS TYPE)

as used by Mr. G. P. Kendall, 3/- post free.

COIL FORMER for A.B.C. Wave Trap cut from ebonite tube to author's design 5/6 (postage 3d.).

Carriage and Packing FREE on Retail orders value £2 and over.

Send stamp for illustrated list and set of leaflets dealing with Radio Press Circuits.

MAGNUM

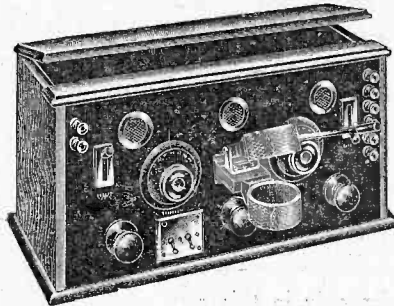

CONSTRUCT THE ALL-CONCERT-DE-LUXE for £9 9 0. (Envelope No. 4).

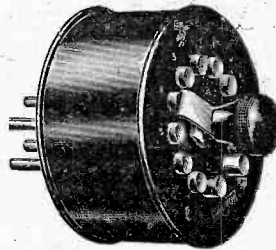

TAPPED REACTANCE UNITS.

As illustrated in "Modern Wireless" (February issue), page 3, and described by Mr. G. P. Kendall. For replacing H.F. Transformers and converting Transformer Coupling to T.A.T.

Type A. Having special resistance in series with last stud for high wavelengths, 15/- post free.
Type B. As above, but including Grid Leak Condenser, 21/- Post Free.

Anode Coils wound and tapped, as used in the Simplicity 3 and T.A.T. 8/- post free.

BURNE-JONES & Co. Ltd.

Magnum House,

296, BOROUGH HIGH STREET, LONDON, S.E.1.
Telephone Hop 6257. Telegrams BURJOMAG
Sedist London. Cables BURJOMAG, LONDON.
Mail order Dept.: 288, Borough High Street, London, S.E.1.

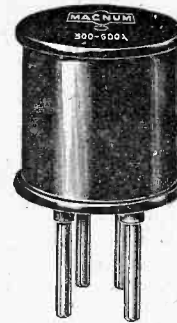

MAGNUM H.F. TRANSFORMERS.
With Protected Windings.
The most efficient H.F. Transformer obtainable. (See report in "Wireless Weekly.") 7/- each. Postage 3d. Guaranteed correctly matched 14/- per pair. (Postage 3d.)

No. 0	150-300
0A	250-525
1	300-600
2	550-1200
3	1100-3000
*4	2500-7000

* Specially recommended for super heterodyne circuits.

Special winding for Anglo-American Six referred to as Neutrodyne Units. Per set of 3 21/- (post free).

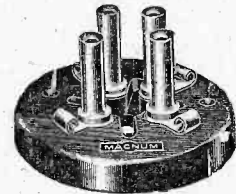

MAGNUM ANTI-CAPACITY VALVE HOLDER.
An entirely new design made from best quality SOLID EBONITE specially channelled. As used on Radio Press sets. 2/6 each (post free)

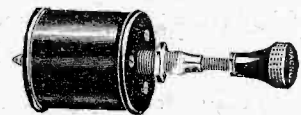

MAGNUM NEUTRODYNE CONDENSER.
Specially designed and recommended for the Anglo-American Six and all Neutrodyne circuits described in Radio-Press Publications 4/6 (postage 6d.).



MAGNUM COIL HOLDERS.

2 WAY 9/6 Postage 6d. (TYPE L).	2 WAY 12/6 Postage 6d.	2 WAY 9/6 Postage 6d. (TYPE R).
--	------------------------------	--

Use MAGNITE Crystal for better reception.

1/- post free.

"TURRET" MASTS

COLUMBIAN PINE MASTS DESIGNED BY NAVAL EXPERTS.

97 Turret Two - £2 4 6	45 ft. Telescopic	£4 10 8
98 Complete - 3 19 6	55 ft. "	8 15 6
42 Telescopic - 4 4 0	58 ft. super -	6 19 6

IMP ON v BLYTHE, 8-9, Sherwood St., Piccadilly W

BRITISH BATTERY CO., LTD.

CLARENDON RD., WATFORD, Herts.
(Telephone: Watford 617.)

for H.T. BATTERIES.

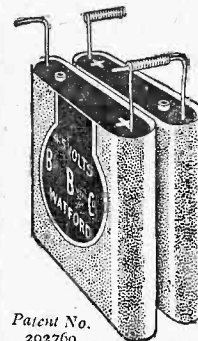

No. 1 W.
Standard Pocket Lamp Size—4½ volt with patent spiral wire terminals and plug sockets to take Wander Plugs.
Note:—1 doz. 54 volts. Used units replaced easily.

To connect in Series insert straight Terminal in spiral of next battery. Bend spiral and thus ensure permanent electrical connection without soldering. (See illustration.)

PRICE CARRIAGE PAID 7/- PER DOZ., WITH PLUG

All standard voltages supplied with 3 volt tappings.

Guaranteed British Made at our own Watford Works

Patent No. 202760.

Barelays 755

A "Micrometer" Filament Resistance

Messrs. Enterprise Manufacturing Co., Ltd., have sent for test a sample of their "Micrometer Filament Dimmer," a one-hole fixing compression type of filament resistance of a design familiar by now, but with a novel element in the shape of replaceable resistance cartridges which are inserted in it to give different resistance ranges. Thus the same external mechanism suffices for several different working

with an ordinary R valve and a six-volt battery, though it was noticed that the lighting-up of the filament was rather sudden, so that the valve might easily be over-run momentarily if great care was not taken.

Evidently there is not a very close relationship between the numbers on the cartridges and the available range, and a considerably greater uniformity of operation, together with a more gradual change of resistance, would be desirable. The principle is evidently very sound and offers great convenience to those who possess many valve sets and wish to use a variety of valves in them, and for renewal of the resistance element if this should happen

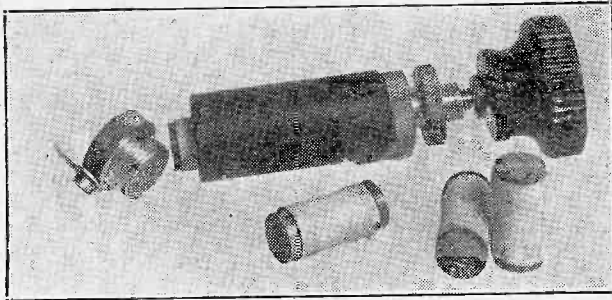

The "Micrometer" filament resistance, complete with spare cartridges.

ranges, for bright or dull-emitter valves; and the change can be made from one to the other range with considerable ease, only one connection having to be disturbed.

The instrument has the customary one hole fixing device of metal bush and lock-nut, and is provided with a substantial knob. The body is about 2 in. long by $\frac{1}{2}$ in. diameter, and carries a milled head brass screwed stopper at the further end. This is removed in order to insert or change the resistance cartridge, and has a terminal screw with soldering tag on one side of it. The other terminal screw and tag are affixed to the side of the bush fitting. The cartridges take the form of small thick rubber tubes with brass plug ends, $\frac{3}{4}$ in. long and some $\frac{3}{8}$ in. diameter, and contain a carbonaceous resistance powder.

With the plug marked "5," the range, as measured, was from .02 to 5 ohms with $3\frac{1}{4}$ turns of the knob; with the "10," from 2 to 80 ohms with $1\frac{1}{2}$ turns; with the "20," from .14 ohm to 20 ohms with $1\frac{1}{2}$ turns; and with the "30," from 2 to 1,000 ohms with $\frac{1}{2}$ turn of the knob. The "10" gave a resistance of 10 ohms with but a fraction of a turn of the knob. The values were roughly reproducible after the resistance element had been "aged" by repeated compression and decompression. In actual trial in reception with the No. "5" cartridge good silent control was obtained

to "pack" or otherwise deteriorate in use.

"Jix" Terminals

Many amateur constructors meet their Waterloo when they attempt the new fashion of wiring up radio-receivers exclusively with bare tinned wire of large gauge, with right-angled bends, in making the soldered joints between the ends of the wires and the back-studs of the terminals, etc., on the back of the panel. The "Jix" terminals, samples of which have been submitted to us by W. E. Bowling, are designed to dispel this difficulty, since with these a panel can be wired up completely without any soldered end-joints of this type at all. The device consists essentially of an elongated back-nut, about $\frac{3}{4}$ in. in length, with the end drilled and split in a manner which makes it an easy matter to obtain a firm hold and good electrical contact with the end of a large-gauge bare wire inserted in the small hole in the end, by pinching the latter with a pair of pliers. It would actually be possible to alter the wiring, though for such a purpose a new "Jix" terminal would be preferable, applied on the same stud.

On trial these terminals were found to hold large square wire securely, and were easy to apply on a No. 4 B.A. back-stud. It is evident that the connection could be readily made permanent by the use of solder, when preliminary

adjustments and trials were completed; for this purpose alone these terminals would effect a great saving of time and temper even for the experienced.

"Shipton" Variable Grid-Leak

A type of variable grid-leak which departs somewhat from the usual form is that submitted by Messrs. E. Shipton and Co., Ltd. This is of the familiar black-lead pencil line variety, but the means adopted to obtain good contact with the pencil-line and to mount the resulting instrument in a practicable one hole fixing form are novel and ingenious.

Externally, the instrument recalls the usual circular type of filament resistance, and has the customary one hole fixing sleeve and collar, and large controlling knob on a central spindle. A case of black insulating material $1\frac{1}{4}$ in. diameter replaces the usual resistance-spiral and its former, however. Within this moves, through an angle of nearly 300 degrees, an arm, carrying in a small holder a short piece of graphite pencil. An external spring causes this pencil to bear down on the end of the case, and to make thus on a circular track the pencil line which provides the leak, this being actually widened out to give a convenient resistance range. Accessible and reasonably large terminals on the end and side of the case provide convenient connection; an indicating pointer is provided which at the same time acts as a locking device for the knob, in a manner reminiscent of the device used on motor valve springs, and is

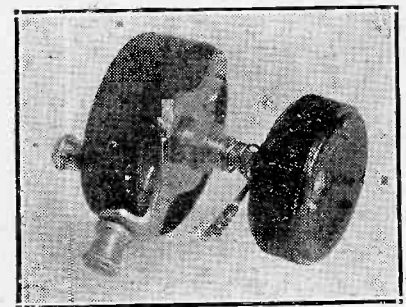

The Shipton variable grid leak.

exceedingly neat and effective here. To remove the knob in mounting the instrument, the spring is eased down, the pointer withdrawn, and the knob then slides off easily; but when in place is locked firmly.

On trial, the resistance range was from about $\frac{1}{2}$ to 40 megohms maximum, and a useful fine adjustment was given over the more usual range employed. A little

The Old way—the New way



The PAD that relieves the pressure

Without doubt, the "Kumfi" De Luxe Ear Pad marks a new era in wireless. Instead of the discomfort caused by pressure from the hard surface of the headphones, we now have a soft, resilient, velvety ear pad which relieves the pressure and enables us to listen-in in comfort. The services of the "Kumfi" Ear Pad do not end there. It eliminates exterior noises, absorbs all moisture, and, being antiseptic, keeps the ear-pieces hygienic and clean. The pad is self-adhesive and only needs pressing against the ear-piece of the headphone. It is equally simple to remove.

'KUMFI' De Luxe EAR-PAD

If your Wireless Dealer cannot supply, send 1/3 to the makers. The pads will be sent POST FREE.

A. DE ST, DALMAS & CO., LTD., LEICESTER



trouble was experienced in getting good contact with one which had been dissected for closer examination, the pencil holder needing close adjustment to give good results. With that which was undisturbed, silent operation was immediately obtained in actual reception, and on both excellent adjustment of leak value was obtained under critical reception conditions.

Push-Pull Switch

A compact and very neat form of single hole fixing panel switch, giving a plain "on" and "off" action, has been sent for test by Messrs. Lissen, Ltd.

With the addition of two washers supplied with the instrument, this will accommodate itself to panels from about 3-16 to 5-16 in. in thickness. It occupies less than a square inch on the panel and an inch below it. Two small but accessible terminals are provided for connections, and the device is operated by a small knob on the central spindle, with a sliding action and "snap" effect. For simple switching in L.T. and in H.T. circuits which do not carry high-frequency currents this switch appears to be eminently suitable, and it is marketed at a very modest price.

"Vernier" Rheostat

A fine adjustment filament rheostat has been submitted for test by Messrs. Economic Electric, Ltd., in which the one controlling knob serves to operate both the main adjustment and also a fine regulating device. A flat spiral resist-

ance of normal type is enclosed in a circular insulating casing, and a contact finger serves to make the coarse adjustment of resistance in conjunction with this. The finger is not, however, secured rigidly to the controlling spindle, but has a play of some 100 degrees. The spindle carries, rigidly attached, a segment of insulating material of corresponding length, over the edge of which is stretched a short length of resistance wire. A spring contact at the back of the main contact on the loose finger slides along the wire, thus putting more or less of this short piece of resistance wire in series with the portion of the main resistance already in circuit. Thus by a small motion of the controlling knob backwards and forwards over the range of play of the loose arm a fine adjustment of the resistance is made.

The instrument submitted had a maximum resistance of about 18 ohms, the fine adjustment being a fraction over 1 ohm. The general finish and workmanship were of a high order; some trouble was experienced with the adjustment, on trial, as the spindle tended to move the main contact-finger from its position of approximate adjustment when moved to and fro to give the fine adjustment, thereby upsetting the whole adjustment. Some pains were taken to set this in order, without much success. When this matter is rectified it is evident that the instrument will have useful applications—e.g., in the "Negadyne" circuit, where extremely critical filament adjustment is called for.

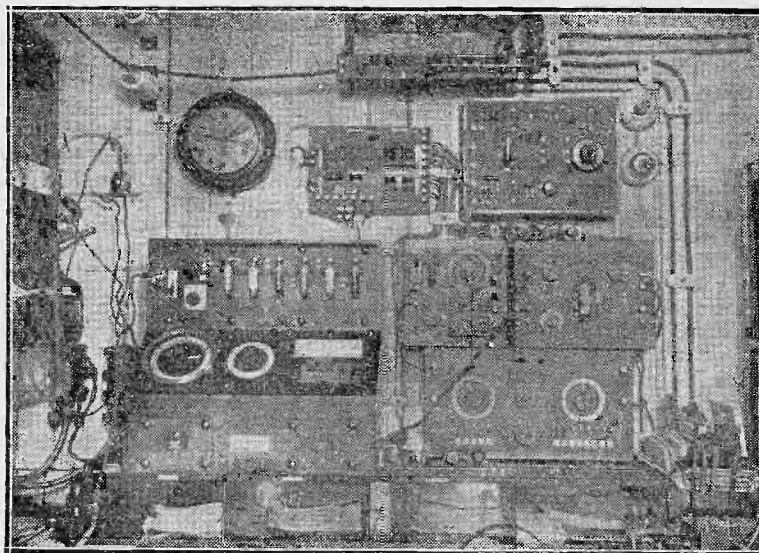

A view of the interior of the wireless cabin on the s.s. "Maloja." The direction-finding apparatus may be seen on the left of the photograph.

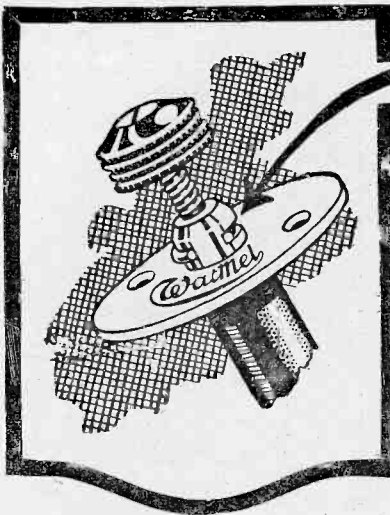

One trouble
less
—to
puzzle you

It is the little things that escape detection. A faulty connection here, and bad contact there—all play their damaging part in robbing you receiver of its fullest power and range. Those experimenters who favour the use of the variable grid leak appreciate how it gives the final touch—clearing reception to make it rich, pure and round in tonal quality. The WATMEL is well known as the first variable grid leak which became available to the home constructor, and its consistent record for reliability to get the best out of the detector valve is without compeer.

Recessed into the collar a D shape spring presses firmly upon the controlling plunger. This device—truly a refinement which improves reception—ensures after constant use that the essential contact is always maintained electrically good.

Watmel

All goods of our manufacture bear this mark. It is your only guarantee.

If you are troubled with poor results pay particular attention to the working of the Detector Valve. Reduce the H.T. voltage consistent with good volume, and incorporate THE WATMEL VARIABLE GRID LEAK.



Patent 206033

5 to 5 Megohms ... 2/5
50,000 to 100,000 Ohms 3/6

Other Resistances to suit any circuit.

Send P.C. for Descriptive Folder
SEE THE TRADE MARK

Watmel

ON EVERY GRID LEAK.
BEWARE OF IMITATIONS.

The WATMEL WIRELESS Co. Ltd.
332a, Goswell Rd., London, E.C. 1.
Telephone CLERKENWELL 7990.

WARNING !

The Watmel Wireless Co. wish to notify the trade and public that their Variable Grid Leak Application No. 206098 was contested in the Comptroller's Court, and on appeal; in both instances the Patent Grant was upheld and costs awarded. It is the aim of this Company to protect traders', customers', and also its own interests by securing Patent protection for the novelties in its specialities, as it is these novelties, invented by experts and exhaustively tested, which are the Hall Mark of all Watmel Products.

The **WADE**
WIRELESS
TOOL-SET

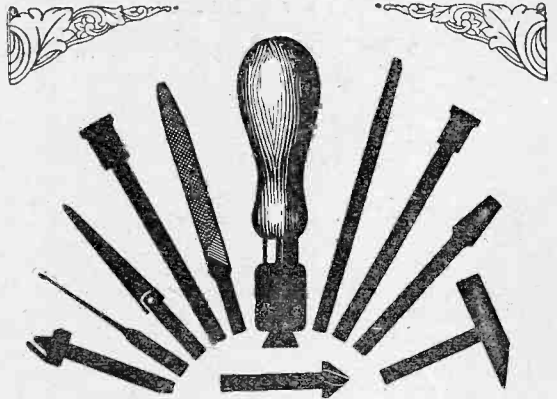

Here, at last, is the real Wireless Tool Set that every Wireless Constructor has been waiting for. No more spoiling a good panel by using the family screwdriver, hammer, and gimlet; no more trying to tighten nuts with an adjustable car spanner or a pair of pliers.

The Wade Wireless Tool Set includes:—

- 1 Extra Length Screwdriver, which enables you to get at screws inside your Set without fouling the wiring system.
- 1 Broad Screwdriver for turning all ordinary screws.
- 1 Wire Bender; invaluable for bending wire to any shape.
- 1 Hammer, for cabinet construction, straightening wire and for use generally where household hammer is far too clumsy.
- 2 Box Spanners, 4 B.A. and 6 B.A., absolutely essential for turning nuts in awkward places. They replace pliers which always burr up the nuts.
- 1 Counter Sink, to enable screw-heads to be sunk to the panel level.
- 1 Reamer, for enlarging holes to any diameter. Replaces numerous and costly drills.
- 1 Bradawl for starting screw-holes.
- 1 Double-sided File for smoothing-off soldered joints, etc.

All these tools fit into the Universal Holder provided.

If you cannot get the tool-set from your local dealer send direct to us, kindly mentioning the dealer's name.



LANITE
The Loud Speaker
CRYSTAL

HERE ARE RESULTS! You too can get them. One user of Lanite reports: "Can operate Baby Sierling Loud Speaker 7 miles from B.B.C. Station. My friends are absolutely amazed." In every box of Lanite a pamphlet containing circuit diagrams is given away. No. 4 circuit is the circuit employed by this satisfied user. There is also a catswhisker of special alloy in every box. Buy a box to-day 1/9. The pamphlet alone is worth the money. If any difficulty in obtaining send 1/9 direct to the laboratories:—Lanite Laboratories, 6 Booth St. East, C.-on-M., Manchester.

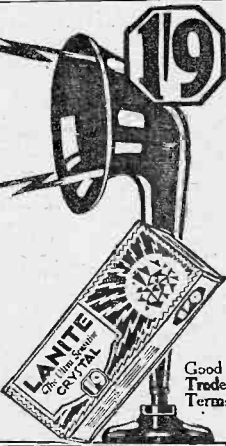

Good Trade Terms

C.A.V. SMALL TOOLS, LTD., 181, Queen Victoria Street, E.C.4.

E.P.S 26

In replying to advertisers, use Order Form enclosed.

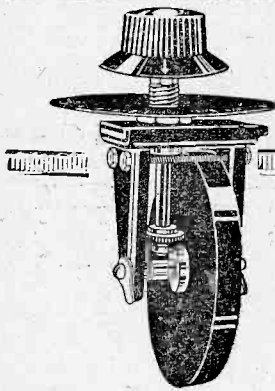

Sharper Tuning—Lower Losses—
Micro Adjustment—No Hand Capacity
—Hermetically Sealed.

BRETWOOD VARIABLE MERCURY CONDENSER

Hand capacity is entirely abolished. This feature renders usable many excellent circuits which are difficult to control. At the same time the use of the Bretwood Condenser in an ordinary circuit will vastly improve results obtainable, and with its compactness enable better methods of wiring to be adopted, thus leading to still better reception.

This new variable condenser marks a great step forward in condenser design. Where other existing types consist mainly of mechanical tinkering, in this case of revolutionary design, the various troubles inherent to the design of multiple condensers have been solved at the root.

Tuning is exceptionally sharp, and at the same time the finest micro control is obtained so that a carrier wave may be tuned in right at the peak. Electrical losses are reduced to a minimum. As the condenser is hermetically sealed it is impossible for dust to enter. The method of mounting, by means of permanent contact against spring phosphor bronze balls, which are all self-cleaning, makes the only perfect type of contact; and never fails.

.003 mfd. . . . 17/6
.005 mfd. . . . 15/-
.001 mfd. . . . 17/6

SUPREME IN DESIGN AND RESULTS

Sole Distributing Agents

The WIRELESS DISTRIBUTING CO. LTD.
WIRELESS HOUSE, STOKES NEWINGTON RD., N.16
Trade Enquiries Invited.

Barclays 928

IF "CHASEWAY" IT'S

The Right Way—Always. **READ THIS.**

S. Jobn's Vicarage,
Wokington.

Dear Sirs

Wokington
March 3 1925

I enclose 4/6, payment and postage, and shall be obliged if you will send me another Chaseway Variable Grid Leak.

I have fitted the one already supplied to me, in place of a much advertised pattern, with amazing results. Your Grid Leak is really variable, and makes the tuning and sensitivity of the set altogether wonderful.

I send this order on behalf of a friend who wants the same difference making in his set that has been made in mine.

I shall be grateful for your prompt attention.
Yours faithfully

Chaseway Electrical Co Ltd.

(Rev) *M. Wright*



Get it from your dealer if you can, but don't let his "Don't stock it, sir," stand between you and the only reliable GRIDLEAK made—"CHASEWAY" Gridleak. .001 to 20 meg. 4/- Anod. Res., 10,000 to 500,000 ohms. 4/- Send stamp for illustrated catalogue of other "CHASEWAY" Specialities and HOME BATTERY CHARGERS for DIRECT and ALTERNATING CURRENTS.

CHASE ELECTRICAL MFG. CO., LTD., 184, Fleet Street, London, E.C.4. Phone: Central 1539.

V. PETHICK—Advertising—London.

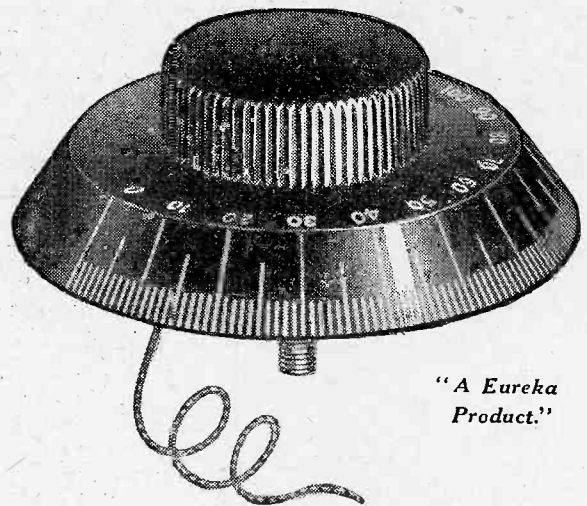

"A Eureka Product."

Inside this Dial is a complete square law Variable Condenser!

THE wonderful new Dial-o-denser has astonished every wireless engineer who has had the opportunity of testing it. For the first time there is available a square law condenser with a minimum capacity of 3 micro-microfarads—a capacity so low as to be utterly negligible. And owing to its unique construction, its

movable and fixed vanes are not subjected to losses due to bad contact and oxidation. The Dial-o-denser is thus true low-loss condenser. Wherever you are using ordinary variable condenser—expensive and bulky—remember that you can replace it with a Dial-o-denser and get vastly superior results.

Only the Dial-o-denser gives you these advantages

1. A true square law reading.
2. A minimum capacity of 3 micro microfarads—the lowest of any variable condenser on the market.
3. All vanes—moving and fixed—totally enclosed and protected against dirt and dust.
4. A genuine low-loss Condenser through the elimination of oxidation losses.
5. Standard 3-inch Dial no thicker than an ordinary Condenser Dial.
6. Permanent contact made by pigtail armoured connection.

Available in three values—all one price **10/-**
.003 mfd., .005 mfd. and .001 mfd.

Manufactured and sold only by:
PORTABLE UTILITIES CO., Ltd.
(Makers of the Eureka Transformer),
FISHER ST., LONDON, W.C. 1.

Remember the name:



The "GOLTONE" (Regd.) "GOLTONE" (Regd.)

MICROMETER REGULATING COIL HOLDERS

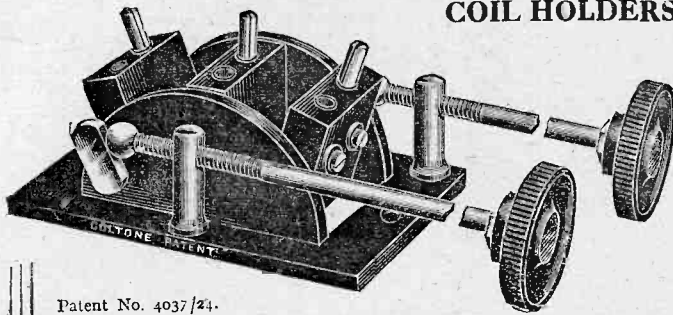

Patent No. 4037/24.

Excellent finish. Maximum insulation. Enables the finest possible tuning, considerably increasing the Efficiency, Selectivity and Reliability of the Receiving Set.

Two Coil Type 7/6
 Three Coil Type 10/6
 See Catalogues for other types.

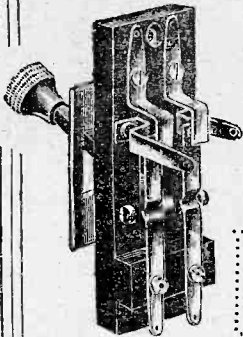

"GOLTONE" NO CAPACITOR SWITCHES

Fitted with screwed front plate for Panel Mounting. Compact. Easy fitting. Sweet action.
 2 Way Double Pole, 3/6 each.
 4 Way Double Pole, 5/6 each.
 Subject Trade Discount.

Large fully illustrated 32pp. Radio Catalogue post free on request.
 Enclose Business Card for Trade Terms.



"GOLTONE" PANEL SWITCH

Flush Type. Size, 1 1/2 by 1 in. Handsome appearance. Price 1/6 each. Refuse substitutes, see the Trade Mark in box.

These lines are stocked by the Leading Radio Stores. Write direct if unobtainable.



Address all communications to Head Office and Works:
 PENDLETON, MANCHESTER.
 STOCKS ALSO HELD AT GLASGOW DEPOT,
 95, PITT STREET.

VALVE RECEIVING SET

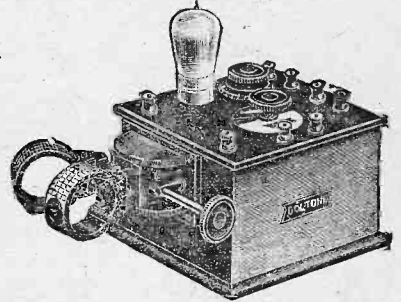

The "Goltone" Single Valve Set gives excellent results and receives with remarkable purity and volume signals within a range of 100 to 150 miles.
 Price complete with Coils for tuning in B.B.C. Stations, £2 18s.
 Plus Marconi Patent Fees, 12/6.

CONSTRUCTIONAL OUTFIT, complete for building up own Single Valve Set, easily put together. Full instructions supplied £1 18s. 6d. Plus Marconi Patent Fees, 12/6.
 See Catalogue No. R/111 for full details of the "Goltone" Wireless Receiving Sets and Constructional Outfits, post free on request.

"GOLTONE" SUPER CRYSTAL

Gives most remarkable results. Sensitive all over. Complete in Glass Tub with Cat's Whisker and Crystal Tweezers.
 Price 1/- each.



RADIO WIRES

Silk, Cotton and Enamelled Instrument Wires supplied in Bulk or on Small Reels; Aerial Wires, Leading-in Wires, Telephone Receiver and Loud Speaker Cords, etc., etc. Keep prices. Send your enquiries.



20 Years ago

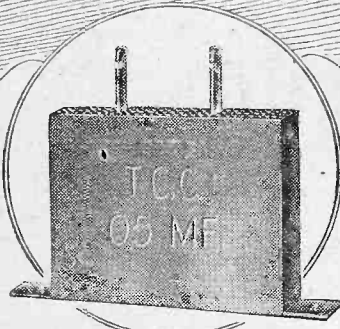

FOR more than twenty years the Telegraph Condenser Co. Ltd. have been engaged in the manufacture of Condensers. Obviously such unparalleled experience devoted exclusively to this one branch of the electrical industry must be productive of better Condensers.

For improved results see that your fixed Condensers carry the mark
T.C.C.

IF YOU WANT VALVES REPAIRED as good as new, send to the firm that repairs them PROPERLY

We are actual makers of valves, and therefore we can repair and exhaust the valve to give the necessary high vacuum. In fact, we do this job so well that

We guarantee:—

Same Amplification.

Same Radiation.

Not to consume more current.

Space wont permit of full price list here, but we'll gladly send you BOOKLET post free on request. Here are prices for the most popular types of valves:—

Bright Emitters 6/6
 Dull Emitters, 2 volt type, 9/-
 '06 type, 10/6. Postage 3d. extra.

If your dealer is not alert enough to collect valves, for RADION repair, send straight off to us with remittance and obtain real prompt service.

**RADIONS, LTD., RADION WORKS,
 BOLLINGTON, Nr. MACCLESFIELD.**

The Largest Valve-Repairing Firm in the World



HERE is a booklet describing the types of valves we make:—**Radion G.P.**—the best bright emitter—fil. 4 volt .48 amp. 10/-
Radion D.E. 34 fil. 2 volt .34 amp. 17/-
Radion D.E. '06 3 volt '06. 20/- (At Dealers, or Direct.) Curves and all particulars are in the booklet, also facts about service accumulator should give. Both booklets mentioned in this advt. are sent post free. Ask for either. We'll send you both!

RADION
 Reliable Valves

B. & D.

ELECTRADIX RADIOS

"C" Valves, Air Force, low loss, 6/6 (post at buyer's risk). Wavemeters, 50/-, 24, 25 and 26. Morse Recorders, 26 10s.; Wheatstone, 28. Alternators, 23 10s. Valve Transmitters, 23. Spark Sets, 15/6. R.A.F. Steel Masts, 2/6 per 5-ft. run. Receivers: 2-valve, 2B, 22; 3-valve, Mk. 4, 23; 5-valve, 25 10s.; 7-valve Marconi, 28. All prices less valves. Bridges, 23 and 25 10s. Res. Boxes, multi-range standards, 1 to 2,000 ohms, 17/6 to 50/-.
 Loud Speakers, 19/-.
 Ebonite Horns, 8/-.
 A.C. Chargers, 24 10s. Charging Dynamos, 23.
 Marconi Rounds Valves, 3/6.
 Milliammeters, 27/6.
 Microammeters, 65/-.
 Amp. and Voltmeters, all ranges. Ohmmeters, 210.
 Testing Sets, 24 to 214.
 Condensers, L.T. to 10,000 v., 1/6 to 22.
 Call or write for new and enlarged catalogue. Post free, 4d.

LESLIE DIXON & CO., LTD.,
 9, Colonial Avenue, Minories, E.1.

*Buses pass the door. Telephone—Avenue 4166.

(A.M.W.)



Secure your Aerials!

Flexible Steel Wire Rope
 For use where strength and strain is required. Extremely flexible and easily handled on pulleys.

No.	Diameter.	Strain	100 ft.
0	1/16"	5 Cwt	4/6
1	3/32"	10 "	6/-
31	5/32"	25 "	10/-
52	3/16"	35 "	12/-

Strainers double ended, for use with above 9d. each 8/6 doz. Orders of 10/- and over Carr. paid, otherwise please add 9d. extra.

SMITH & ELLIS, Ltd. (Dept. 85),
 11, Little Britain, Aldersgate Street, E.C.1.

Radio Press Envelopes

The most complete guide to wireless construction ever devised. They contain exact size panel and wiring blue prints, complete working drawings, sheets of instructions regarding construction and working, lists of components, and many photographs on beautiful art paper showing the set and wiring from every possible angle. Every possible detail is explained and you cannot go wrong.

Here is the complete list for you to choose from —

- 1 How to Build an S.T.100 Receiver ... 1/6
 By John Scott-Taggart, F.Inst.P., A.M.I.E.E.
- 2 How to Build a 4-Valve Receiver ... 2/6
 By Percy W. Harris.
- 3 How to Build the "Simplicity" 3-Valve Set ... 2/6
 By G. P. Kendall, B.Sc.
- 4 How to Build the All Concert-de-Luxe Receiver ... 2/6
 By Percy W. Harris.
- 5 How to Build the Omni Receiver ... 2/6
 By John Scott-Taggart, F.Inst.P., A.M.I.E.E.
- 6 How to build the A.B.C. Wave Trap ... 1/6
 By G. P. Kendall, B.Sc.
- 7 How to Build a 2-Valve Amplifier-de-Luxe ... 1/6
 By Herbert K. Simpson.
- 8 How to Make a 1-Valve Reflex Receiver 1/6
 By Herbert K. Simpson.
- 9 How to Build an Efficient Single Valve Set ... 1/6
 By Herbert K. Simpson.

All above can be obtained from wireless dealers, booksellers—or direct (plus 3d. postage) from Dept. M.

Radio Press, Ltd.

BUSH HOUSE,
 STRAND, LONDON, W.C.2.

Barclays Ad.

DO YOU ALWAYS obtain FULL satisfaction when buying Wireless Goods? — If not, write

WILKINSON'S WIRELESS SERVICE. Estd. 1922.
47, CANNON STREET, PRESTON.
Over 700 different lines in stock—
Opera Phones sold with a guarantee
of satisfaction, p.f. at 17/6 a pair. 1 in.
Matt Ebonite, our standard quality, 1d. per
sq. in. WE RELY on our RELIABILITY.

SETS, PARTS, PHONES, LOUD-SPEAKERS,
supplied on easy payment system. Send for
latest Catalogue, just issued.—The WIRELESS
DISTRIBUTING CO., LTD., WIRELESS HOUSE,
STOKE NEWINGTON ROAD, N.16.

Cabinets you want!
—for Radio Perfection—
PICKETTS—are used for Finest Sets.
ESTIMATES PER RETURN.
Send for Cabinet List, Free.
PICKETTS CABINET (M.W.) WORKS,
BEXLEY HEATH, S.E.

YOUR CABINETS

The original House for hand-made and
polished Mahogany, Oak and Teak
Cabinets to customer's own design.
All timber used in my cabinets is
carefully selected and guaranteed
THOROUGHLY seasoned.

AN APPRECIATION

London, E.C.3.
To Messrs. W. H. Agar,
19, Whitecross Place, E.C. 2.
27th Feb., 1925.

Dear Sirs,
I am not in the habit of writing testi-
monials, but the waxed teak case you
have just made for me deserves one—
both as to quality, accuracy and price.
Yours faithfully,
R. H. B.

YOUR PANELS

Finest quality 1/2 in. thick Ebonite cut
to size and fitted, 1/2d. per square inch.
This Ebonite is guaranteed British
Made to Post Office Grade "A"
Specification, which is the best for wire-
less purposes. It is rich black in
colour, takes a brilliant polish, can be
threaded with ease, and possesses a
high degree of mechanical strength.

W. H. AGAR
Manufacturer of Telephone and Radio
Apparatus.
Tel.: London Wall 3305.
19, Whitecross Place, Wilson Street,
E.C.2.

CABINETS.

The Popular "All Concert-de-Luxe," 14/6,
post free.

A.B.C. Wave-Trap, 4/6, post free.

"Paragon" Panels Fitted at Lowest Prices.
Send your requirements. We will quote you.

CATTERMOLE BROS., 17, Waller Street, HULL.

REPAIRS
TO HEADPHONES
TO LOUD SPEAKERS
TO COILS
Rewound to any Resistance and
made equal to new. Price
quoted on receipt of instruments.
Prompt Delivery
THE VARLEY MAGNET CO.
(Dept. M), WOOLWICH, S.E.18
Established 26 years.
Phone: Woolwich 888.

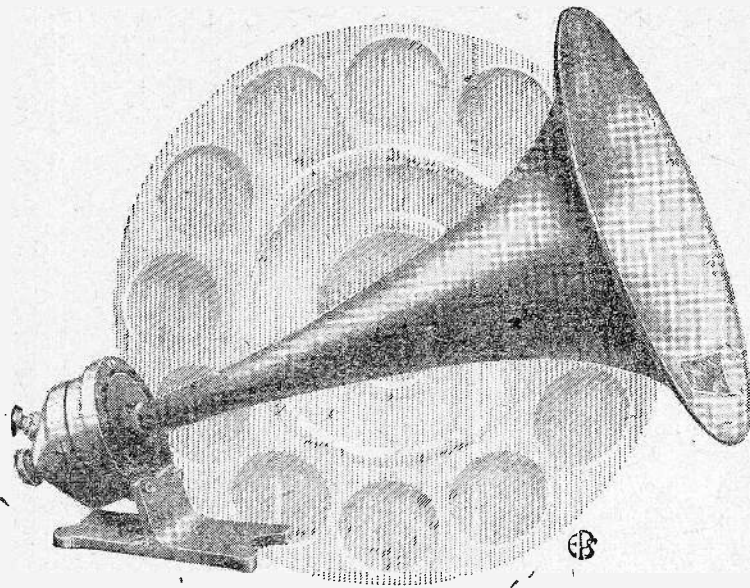

**21/- TRUE MUSIC
: MINOR :**

We do not guarantee that the
TrueMusic Minor will work unaided
from a Crystal Set. But several
purchasers have, nevertheless,
written to us to say that it will do
so quite satisfactorily.
That is sufficient proof that with
one stage of amplification this
remarkable Loud Speaker will give
results rivalling in tone and
volume those of many larger and
dearer models.
Ordinary headphones weigh about
1/2 lb., whereas T.M.C. No. 3 Light-

weight Headphones weigh only 6 1/2
ounces. They are therefore well
worth the extra half-crown. (Note
that the earpiece attachments do
not catch in feminine hair, and
the connections are 6 ft. long, thus
ensuring all-round comfort.)
T.M.C. No. 2A Headphones are
3/- cheaper than the No. 3 Head-
phones. They are just as good,
but slightly heavier, and both give
signal reception that is "Clear as
Crystal."
British made by British Labour.

Arrangements are being rapidly completed so that you can buy all T.M.C. products from
every wireless retailer. If, however, you have any difficulty, we will supply you
direct. When writing, we shall appreciate it if you will send us the name and address of
the retailer who is unable to supply.

T M C

The Telephone Manufacturing Co., Ltd.
(Makers of the famous Laryngaphone),
Hollingsworth Works, West Dulwich, S.E.21



T.M.C. No. 2a Headphones
Resistance 4,000 ohms,
19/6.

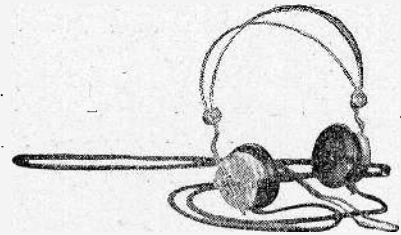

T.M.C. No. 3 Lightweight
Headphones, weight 6 1/2
ounces. Resistance 4,000
ohms, 22/6.



No. 10 of a Series.

The Living Artiste

THERE'S an indescribable feeling of pride awaiting every purchaser of a Eureka Transformer. Considerable prestige is attached to the use of a Transformer found in some of the best known Broadcast Receivers. The knowledge that it is the instrument selected—almost without exception—by the leading technical men of the day for their most important experiments is a continual safeguard of quality. And the feeling that it is bought principally by those whose experience enables them to judge the merits of a Transformer has ever been a remarkable stimulus to its popularity.

After all, there is a very real satisfaction in the knowledge that your Receiver, at any rate, is entirely free from criticism in tonal purity because you have selected the very best Transformer that money can buy or that Science can build.

A Transformer, in fact, that can always be relied upon to "re-create the living Artiste."

Portable Utilities Co., Ltd.,
Fisher Street, London, W.C.1

Eureka
Jongert
Grand 30/-

Eureka 22/6
No. 2.
(For Second Stage)

Supreme **EUREKA** for Tone

Illustrations 21d. 2424

A.B.C. WAVETRAP



Can you cut out your local station?

How often is that question asked by radio enthusiasts? The answer is to be found in the Radio Press Envelope No. 6, which contains full details for the construction of the A.B.C. Wave Trap—an instrument which is the result of much research by G. P. Kendall, B.Sc., into the question of the elimination of undesired signals. This instrument contains no less than 3 distinct types of wave trap arrangements, any one of which can be brought into operation at will.

The contents of the Envelope include a general treatise on the experiments, instruction sheets, blue prints, photographs and working drawings. When tested 3 miles from 2LO the A.B.C. Wave Trap completely eliminated the London Station, and brought in Bournemouth. Although theoretically a loss in signal strength must be admitted, it is so small that it is seldom apparent to the human ear.

This highly efficient Wave Trap gives a choice of working with either A, B or C type of eliminator circuits, and its great efficiency is obtained by the elimination of losses in design.

We have every confidence in telling our readers that the A.B.C. WAVE TRAP will enable them to cut out their Local Station without sacrifice of signal strength, provided always that their aerial and earth systems are of average efficiency.

You can build this Wave Trap for about 30/- inclusive of handsome cabinet and coils which are built into the design. Normally Constructed to operate on the 300-600 metre band.

This Envelope may be obtained from your regular wireless dealer, newsagent, or direct from Dept. M, Radio Press, Ltd., Bush House, Strand, London, W.C.2.

Price 1/6 (Post Free 1/9).

Build yourself this Wavetrapp
and cut out your local station.

RADIO PRESS, LTD.
Bush House, Strand, London, W.C.2

**It makes a
wonderful
difference**

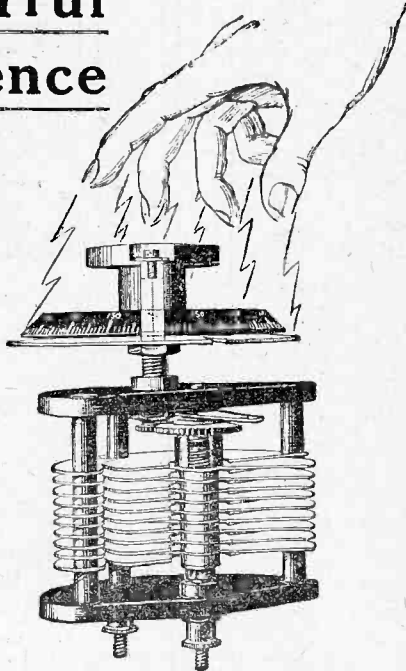

**Congratulations continue to pour
in from users of the "Fu'stop"
Variable Condenser.**

FROM SOUTH CROYDON.

"We had a long experiment last night with your Fu'stop Condenser and brought in 12 distant stations that other condensers would not look at."

ORMSKIRK.

"I tried one of your .0005 Condensers a few weeks ago and it has proved so satisfactory that I am discarding a more expensive .0003 condenser for yours."

LIVERPOOL.

"I replaced the "Fu'stop" in my set and in half an hour had tuned in thirteen stations. I also find it easy to get London and Bournemouth, quite separate from Manchester, which I have never managed before. This speaks volumes for the condenser."

"May I therefore once again express my satisfaction and appreciation of your condenser and method of business, which compare so favourably with other firms. A satisfied customer is the best advertisement possible, and I shall always be pleased to recommend you to others."

.00113/6 .000310/3
.000511/3 .00029/6

Protected throughout the World.

Stocked by most Wireless Dealers, but if you have any difficulty in obtaining, write to

J. H. NAYLOR, LTD., WIGAN



VARIABLE CONDENSER

Guaranteed to Abolish Hand Capacity

YOUR OPPORTUNITY!

Thousands of men have lost their one great opportunity in life through leaving over until to-morrow that which should have been done immediately. You have to move in the world, you cannot stand still, so why not move in the right direction? Why not move now?



We have helped thousands of others to a successful career, we may or may not be able to help you, but in any case it costs nothing to acquire our advice is Free, and there is a possibility that it may be worth thousands of pounds to you, it may change your whole career, it may help you up in the world socially and financially, it certainly cannot harm you: therefore, you have all to gain and nothing to lose by seeking our advice.

We have booklets setting out the possibility in connection with each of the subjects shown in the lists, send for the one in which you are interested, or ask for our Private Advice.

**WE TEACH
BY
POST**

Have You ANY Ambition?

MY ADVICE IS FREE.

The Bennett College specialises in all Exams. in the following subjects and guarantees tuition until successful. No extra fees. Most Moderate Charges. Payable Monthly. All Text Books Free. Expert Tutors for every Department.

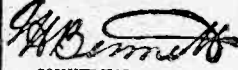

- COMMERCIAL.**
Accountancy
Adver. Writing
Salesmanship
Auditing
Banking
Book-keeping
Commercial Arithmetic
Company Law
Costing
Economics
English and French
Executive Law
Foreign Exchange
Modern Business Methods
Secretarialship
Workshop Organisation

- TECHNICAL.**
Architectural Drawing
Building Construction
Clerk of Works' Duties
Boiler Engineering
Boiler Making
Chemistry
Civil Engineering
Concrete and Steel
Draftsmanship
Electricity
Engineering
Foundry Work
Internal Combustion Engines
Marine Engineering

- TECHNICAL—Cont.**
Mathematics
Matriculation
Metallurgy
Mining
Mine Surveying
Motor Engineering
Naval Architecture
Pattern Making
Sanitation
Shipbuilding
Structural Engineering
Surveying and Levelling
Telegraphy & Telephony
Wireless Telegraphy
Works Managers' Course

WRITE FOR FREE BOOKLET

to The Bennett College, Dept. 134, Sheffield, naming the subject you are interested in. Parents should seek our advice for their sons. Please state your age. Courses specially combined to meet all requirements. Why stay in the rut?

**ENGINEERING
DICTIONARY.
PART ONE FREE.**
To extend the name of the Bennett College we are publishing an Illustrated Encyclopaedic Dictionary of Engineering. Civil, Motor Elect., Mech., etc. You may have Part I FREE. Send for Part I to-day you are under no obligation.





**HUNT'S
NEW MODEL
CRYSTAL
DETECTOR**

(Fig. No. 922)

CODEWORD —
"VERNIER"

PRICE as illustrated **4/-** EACH but less crystal

MICROMETER ADJUSTMENT (without moving cats-whisker or cap.)

DUSTPROOF GLASS CYLINDER 

CATSWHISKER OR DOUBLE CRYSTAL (Spare cup, with fixing screws supplied free.) 



REGISTERED TRADE MARK

FIG. No. 922

A. H. HUNT, LTD.,
(DEPT. 5), H.A.H. WORKS,
TUNSTALL RD., CROYDON.
"Keyage, Croydon" Addiscombe 1584-5



Dimple Cheeks!

THE kind of Headphones that children want are those that are light in weight, that fit closely to the ears, that have long cords to allow free movement, and, finally, that are really sensitive to the merest whisper.

But aren't these the chief qualifications of Headphones for grown-ups too? If you have always felt that Headphones must necessarily be uncomfortable, heavy and clumsy you have probably never tried **Brown Featherweights**. Weighing only six ounces (including cords) they are a masterpiece of ingenuity.

And now that they have been reduced in price to 20/- per pair they represent better value than ever. Why not ask your dealer to show you a pair so that you can compare them for comfort with those you are at present using.

Reduced Price F. Type HEADPHONES 20/- per pair
 120 ohms & 4,000 ohms

S. G. Brown, Ltd., Victoria Road, N. Acton, W. 3.
 19, Mortimer St., W. 1. 15, Moorfields, Liverpool. 67, High St., Southampton.

Brown

HEADPHONES AND LOUD SPEAKERS.



Owing to its great popularity we are now publishing the 6th Edition of this book, which has been written for the purpose of providing the wireless amateur and the general public with sufficient information concerning the actual construction of wireless receiving apparatus. Although the information contained within these pages is essentially of a practical nature, an indication has been given wherever possible of the function of each component. It is obvious, therefore, that if this is fully understood, the reader is in a position to produce a really efficient piece of apparatus. The mechanical construction has been reduced to a minimum, but this, of course, may be elaborated, if desired. Every component has been thoroughly tested, not only by the author, but by a number of experimenters with whom he is acquainted. Hence it is with every confidence that this book is placed in the hands of the wireless amateur.

CONTENTS.

ANODE AND GRID RESISTANCES
 General considerations—A graphite grid leak—An Indian ink resistance—A continuously variable resistance—An anode resistance for panel mounting—High resistance mixtures—Determination and regulation of resistance values.

FILAMENT RHEOSTATS AND POTENTIOMETERS
 General considerations—A single valve resistance—A stud type resistance—A rheostat for panel mounting—A graphite potentiometer—A liquid potentiometer.

INDUCTANCES
 General types—Basket coils—Slab and hank coils—Cylindrical inductances—A loose coupled tuning inductance—Bank and pile winding—Honeycomb coils—Duolateral coils—Other lattice coils—Variometers—Effect of dead end and self-capacity.

FILAMENT AND ANODE BATTERIES
 General considerations.

CONDENSERS, DETECTORS, AND TEMPORARY COMPONENTS
 A valve holder—Variable condensers—Vernier condensers—Grid condensers—By-path condensers—Crystal detectors.

AUDIO-FREQUENCY AMPLIFICATION
 General considerations—The bobbin—The core winding—Other types—Telephone transformer.

RADIO-FREQUENCY AMPLIFICATION
 General considerations—Resistance capacity unit—Reactance capacity units—Types of transformers.

THE CONSTRUCTION OF WIRELESS RECEIVING APPARATUS,
 By Paul D. Tyers.
 Series No. M. 5, price 1/6, post free 1/8
 Obtainable from all newsagents, booksellers, or your local wireless dealer.
 If ordering direct be sure and quote Series No. M. 5.
Radio Press Ltd.
 Bush House, Strand, London, W.C.2.

"UTILITY" VARIABLE SQUARE LAW CONDENSERS

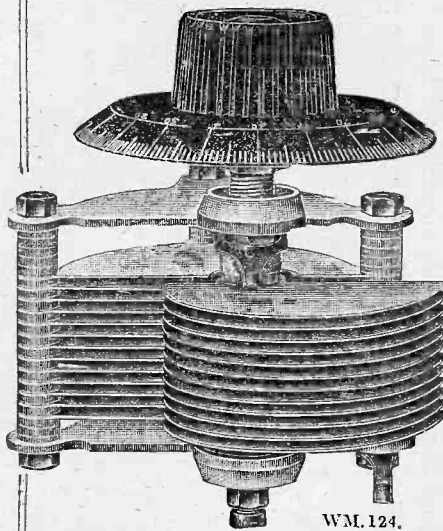

WM.124.

at
same price
as our
ORDINARY

PRICES.

Ref. No.	Cap.	Price.
WM.123	.001	12/6
WM.144	.00075	11/9
WM.124	.0005	10/6
WM.125	.0003	8/9
WM.145	.0002	7/9
WM.146	.0001	7/6

Vernier 2/6 extra.
Fitted with
Radion Dials.

NO-CAPACITY

The "UTILITY" NO-CAPACITY SWITCH, as used in the constructional articles appearing in this journal.

Specially designed by electrical engineers to reduce the electrostatic capacity, this switch has proved to be exceptionally reliable in action and has self-cleaning contacts.

Size	Knob Type	Price
2 "	WM.130	2 4/-
3 "	WM.130	3 5/-
4 "	WM.130	4 6/-
5 "	WM.130	5 7/-
6 "	WM.130	6 8/-

Size	Lever Type	Price
2 "	WM.147	2 5/-
3 "	WM.147	3 6/-
4 "	WM.147	4 7/6
5 "	WM.147	5 10/-
6 "	WM.147	6 10/-

Black bronzed, lever pattern, nickel-plated, 6d. each extra.

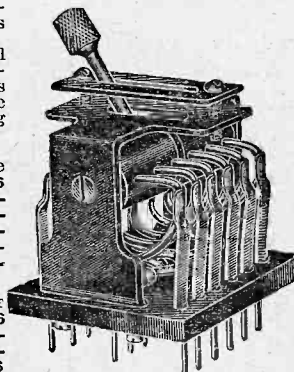

WM. 147/6.

SWITCHES

Manufactured by
WILKINS & WRIGHT LIMITED, ESTD. 1867.
UTILITY Works, Kenyon Street, Birmingham.



Tubular Fixed Condenser



**EXACT CAPACITY—EASILY FIXED
MINIMUM SPACE—NO SOLDERING
REQUIRED.**

THE outstanding and unique features of the "K" tubular fixed condenser will at once be apparent from the illustration: Its design ensures a strictly accurate capacity which cannot fluctuate with climatic conditions, and it is ideal for wiring into modern sets where minimum space is available. It can be connected direct to wires, or by means of the fixing brackets supplied with each condenser. A Wates production that is rapidly replacing the earlier models!

0.001 }
0.002 } 2/- each.
0.003 }
0.006 }

0.0001 }
0.0002 } 1/9 each.
0.0003 }
0.0005 }

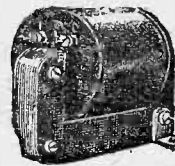

The SUPRA Transformer

Its sectional windings are the secret of its success. Built to give maximum amplification, freedom from distortion and perfect tone. Perhaps your trouble is due to the transformer you are using—in any case it will pay you to fit a Supra at the price of

12/6 (RATIO 5 to 1)

The SUPRATONE Headphones

Mellow and clear tone has been the objective in these leather weight headphones. Adjustable to any head, they are light and comfortable, and can be worn through the largest programme. Wound to a resistance of 4,000 ohms, and complete with best quality cords.

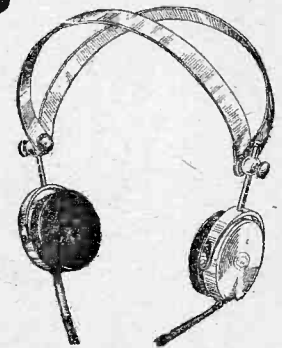

16/6

Send for our Latest Free Catalogue

Just published, and full of interesting bargains, this Catalogue should be in the hands of every wireless worker. Sent post free on receipt of request.

Wates' Products are sold by all discriminating Radio Dealers, who will willingly demonstrate. We can supply carriage paid but your dealer's name must be enclosed with order.

WATES

Bros., Ltd.,

12-14, Great Queen St., Kingsway, W.C.2

Phone: Gerrard 575 and 576. Grams: Zywateseng, Westcent-

WORKS: LONDON, BIRMINGHAM AND WESTCLIFF.

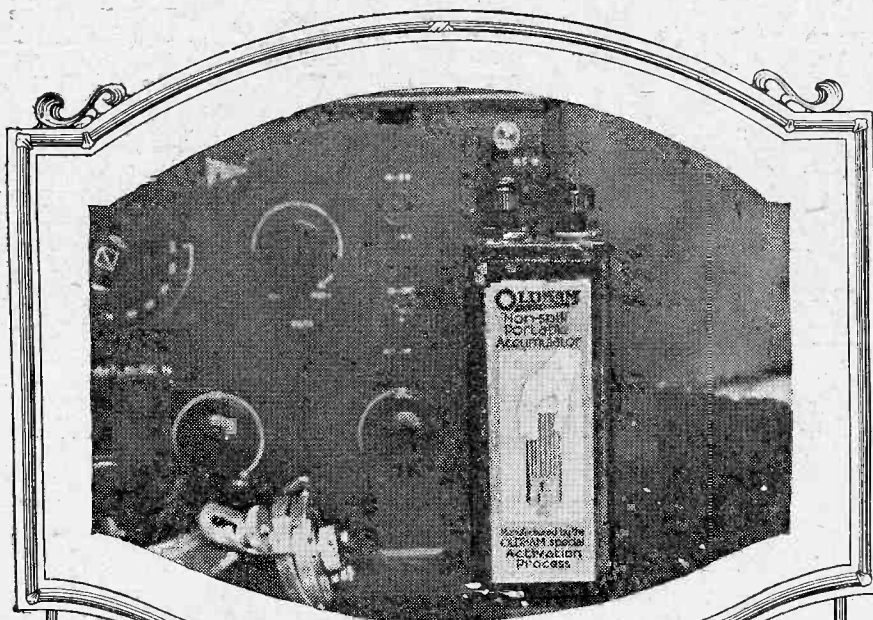

Cheaper and more reliable than Dry Batteries for all Dull Emitters—

WITH this new non-spillable 2-volt, 10 amp. hour Accumulator all your Dull Emitter troubles will be ended. You won't experience the disappointments of good reception one night and poor the next. More than half the complaints about Dull Emitter Valves are due to faulty filament lighting. How can you expect to get good results from your Valves when you are using batteries originally intended for ringing bells and other intermittent duties? Experts are advising users of Dull Emitters not to use Dry Batteries unless they can afford the very large (and expensive) ones—otherwise they will surely get a fluctuating output which causes distortion and loss of sensitiveness.

The sensible way is to pay a few shillings more in the first place and get an Oldham Portable Accumulator, which will last for several years and cost but a few pence for a re-charging. Use two of them in series for '06 valves and charge them every 6 or 8 weeks. Such valves as Wuncells, D.E.R.'s and 1-volt Oras only require one—no matter how many valves there are in the set. All good Dealers stock Oldham Accumulators.

Filled with special non-spillable vents. Can even be shaken upside down without spilling contents. 2 volts, 10 amp. hours (continuous)

12/6

**Oldham & Son Ltd.,
Denton, Manchester.**

LONDON :
Gt. Chapel Street, Oxford Street, W.1.
NEWCASTLE : 1, St. Mary's Place.
GLASGOW : 120, Wellington Street.

OLDHAM
ACCUMULATORS

Gilbert Ad. 2447



Don't worry
it out yourself
-let an expert
help you

PERHAPS you have built a Set and you cannot get it to work—don't worry, let a Radio Press expert help you. Probably you have made some little slip in the Circuit—maybe you have mis-read the wiring instructions. All you need is a copy of

**Pictorial
Wireless
Circuits**

By Oswald J. Rankin.
(Radio Press Series No. 8.)

This Book contains scores of different Circuits, each one of which is shown in pictorial form instead of the more technical diagrammatic manner.

Thousands of beginners have bought it and have been able to appreciate for the first time how easy it is to wire up a Set when the Circuit diagram is understood.

No matter which type of Set you are building, whether Crystal or multi-valve, and whichever type of tuning you will use, variometer or plug-in coils, you will find a wide variety of practical circuits shown in a manner even the veriest novice can readily understand.

From all Booksellers or sent post free 2d. extra direct from Publishers. **1/6**

When ordering quote Series No. M.3.

Radio Press Ltd.

Bush House, Strand, London, W.C.2.

April, 1925

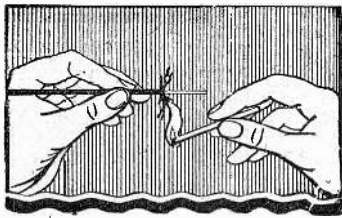

To make a neat end with Glazite

You can quickly make a neat end to "Glazite"—the new coloured connecting wire—by burning off the frayed cotton with a match. The charred ends can be rubbed away with the fingers, leaving a perfectly clean finish. "Glazite" consists of a tinned copper wire covered first with cotton and then with a film of heavy insulating material which makes it flameproof and impervious to moisture. "Glazite" is made in four colours, red, yellow, blue, and black. Price 1/6 per coil of 10 feet at all dealers.

GLAZITE

REGD.

The new coloured connecting wire

The LONDON ELECTRIC WIRE CO.
AND SMITHS LTD.

(Makers of Electric Wire for over forty years)

Playhouse Yard, Golden Lane, London, E.C.1.

Telegrams: Electric, London. Telephone: Clerkenwell 1388, 1389, 1390, 1391



A Boon to all Wireless Experimenters

AND THE BROADCASTING PUBLIC

PRICE COMPLETE

5/9
POST FREE

NO MORE WIRELESS PERPLEXITIES



THE RADIOTESTER

PATENT APPLIED FOR

A unique invention with a thousand and one different uses for testing wireless circuits and components; will trace any fault in your set in a few seconds.

Send P.O. for 5/9 for immediate delivery. Descriptive leaflet on application.

Telephone: Holb. 5064. Tel. and Cables: Ioritogsa, Holb. London.
The British and Colonial Industries Association Limited,
317, HIGH HOLBORN, LONDON, W.C.1
(Opposite Chancery Lane Tube Station).

MODERN WIRELESS



REG. N° 457042

Taking the Guess Out of Radio

Every individual THERLA Condenser tested and guaranteed by Faraday House

Ask your dealer for a fixed condenser and radio becomes a great guess. Insist upon Thera Fixed Condensers and take the guess out of radio. You build not with an arbitrary guaranteed capacity but **Tested Capacity**. Therein lies the great advance from mass production with its inaccuracies to laboratory and scientific building.

Use the Thera Grid Condenser; the Thera across I.P. and O.P.; the Thera across the Telephones; the Thera for Constant Aerial Tuning; the Thera wherever a fixed condenser is employed. The Thera is more than accurate—it is tested capacity. **Build with the Thera Fixed Condenser and you have a standard condenser of tested and proved capacity.**

PRICE: { .001 mfd. to .0015 mfd. . . . 1/3 each.
 .002 mfd. to .006 mfd. . . . 2/- each.

From all dealers.



Sole Distributors:

Sel-Ezi Wireless Supply Co. Ltd.
6, GREEK STREET, LONDON, W.1. Telephone: REGENT 1140.
20, OLD HAYMARKET, LIVERPOOL.

Barclays Ad. 927

Finston ONE-HOLE Fixed Condensers

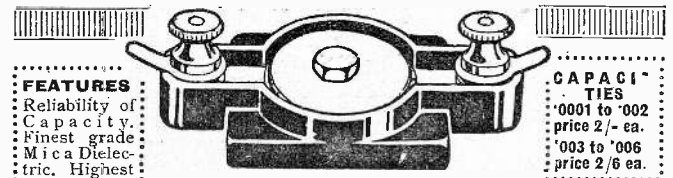

FEATURES

Reliability of Capacity.
Finest grade Mica Dielectric. Highest possible quality Cooper Foil. Adapted for Terminal or soldered connections.

CAPACITIES

'0001 to '002 price 2/- ea.
'003 to '006 price 2/6 ea.

Guaranteed within 5 per cent. of stated capacity, this accuracy has never before been obtainable by the public. The only one-hole fixing condenser on the market. Buy one. Test one. It will prove our statements and thoroughly satisfy you.

FINSTON SQUARE LAW CONDENSERS

Aluminium top and bottom plates, high grade ebonite composition knob and dial cleanly engraved 0-180. Vanes 98 per cent pure ALUMINIUM.

PRICES.
'001 9/- '0003 7/6
'00075 8/6 '0001 6/6
'0005 8/- '00005 6/-

FINSTON STANDARD VARIOMETER

Another trustworthy Finston component. Extremely moderate price. Ebonite stator, high-grade ebonite moulding rotor, engraved dial and knob. 5/6

If your dealer cannot supply Finston Components, send your order to us together with his name and address, please!

LIGHTING SUPPLIES CO.
2, FINSBURY AVENUE, LONDON, E.C.2

Barclays 891.

In replying to advertisers, use Order Form enclosed.

And such a surface!

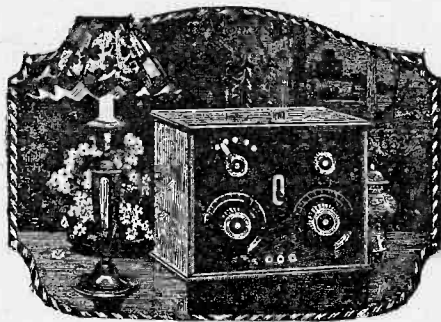

NOTHING improves the appearance of a Set more than a handsome polished panel, but because ordinary ebonite receives its bright surface by metallic methods, the wireless enthusiast is always advised to sandpaper it.

But Radion receives its polish in a different way and its beautiful lustre should not be removed before use.

The next time you go to your Dealer's ask him to show you a Radion panel and compare it with ordinary ebonite. Note the richness of its sheen—mere words cannot describe it—and you'll readily appreciate the wonderful difference it can make to the appearance of a Set.

But Radion excels in efficiency, too. It is infinitely superior to ordinary

ebonite. Developed in the factories of the largest manufacturers of ebonite in the world it has been evolved as the panel material *de luxe* for wireless.

Its insulation properties are exceptional and its dielectric constant has been reduced to 3.9. It cuts well, takes a good thread and never warps. Its handsome polished surface repels moisture and does not attract dirt. Radion is so tough that panels $\frac{3}{16}$ " thick are quite sufficient for all ordinary use. And finally this *de luxe* material is supplied in a large range of sizes in black and mahogany with dials and knobs to match. Each panel has its edges squarely cut and ground. If your own Dealer is out of stock of the panel you require he can get it by return, or, if you prefer it, you may order direct.

RADION TRADE MARK

PANELS AND DIALS

Size	Black	Mahogany	Size	Black	Mahogany	Size	Black	Mahogany
6" x 7"	3/6	4/3	7" x 14"	8/-	10/3	8" x 26"	17/6	21/3
6" x 10 $\frac{1}{2}$ "	5/3	6/6	7" x 18"	10/6	12/9	9" x 14"	10/6	12/9
6" x 14"	7/-	8/6	7" x 21"	12/3	15/-	10" x 12"	10/-	12/-
6" x 21"	10/6	12/9	7" x 24"	14/-	17/3	12" x 14"	13/3	16/-
7" x 9"	5/3	6/6	7" x 26"	15/-	18/6	12" x 21"	19/9	24/3
7" x 10"	5/9	7/3	7" x 30"	17/9	21/6	14" x 18"	19/9	24/3
7" x 12"	7/-	8/6	7" x 43"	28/-	34/6	20" x 24"	39/6	48/-

SPECIAL NOTE: All Radion Panels are $\frac{3}{16}$ " thick. In addition to the sizes listed above we can supply by return any special size cut to measure at the following prices:—Black, 1d. per sq. in.; Mahogany, 1 $\frac{1}{2}$ d. per sq. in.

AMERICAN HARD RUBBER COMPANY (BRITAIN) LTD.

Head Office: 13a Fore Street, London, E.C.2.

Depots: 120 Wellington St., Glasgow. 116 Snow Hill, Birmingham.

Irish Agents: 8 Corporation St., Belfast
Gilbert Ad. 2453



PROBABLY no writer of Books and Articles dealing with the constructional side of Wireless is more popular than Percy W. Harris. The reasons for this may be two-fold. Firstly, because he takes extraordinary pains to make every detail clear and intelligible to even the veriest novice. Secondly, because the Instruments he describes, although refreshingly original in design, give extraordinarily good results.

No reader of this book, "Twelve Tested Wireless Sets," by P. W. Harris, need be afraid that he does not possess sufficient skill to build one of his Receiving Sets or that elaborate tools are necessary. If he has sufficient patience to follow clear diagrams and explanations, and if he can handle intelligently the ordinary household tools, then success is assured.

ORDER A COPY TO-DAY.

PRICE 2/6 (Post Free 2/8).

Obtainable from all Booksellers, Newsagents and most Wireless Dealers, or direct from (Dept. M)

RADIO PRESS LTD.
BUSH HOUSE, STRAND,
LONDON, W.C.2.



A Sturdy Fellow

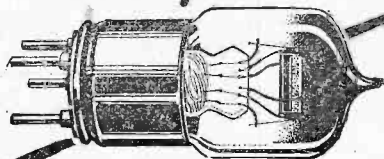

built for hard work—
but sensitive and always reliable

The C. & S. DULL EMITTER 2v., 0.2a. (227)

*gives increased amplification and
purer reception without distortion.*

NEW ZEALAND & NEW YORK

received on a single valve.

12/- each. Also made 0.06a., (227L) price 15/-

Special Process Dry Batteries
227.....7/6 227L.....5/-

CRAIK & SMITH (Desk F), Allen Street, E.C.1

Phone: Clerkenwell 7346. Send for illustrated catalogue.



**You, also, can
increase your salary**

"After 17 years with a London engineering firm I was receiving only £4 10s. 0d. a week, but becoming an I.C.S. student in Civil Engineering, I quickly got an appointment at £1,000 a year, which steadily increased to £2,500!"

Many thousands of such messages from grateful students have been received by the International Correspondence Schools, the originators of

SPARE TIME STUDY BY POST

The I.C.S. Diploma is known, valued, respected in every country. It is an insurance against unemployment, and wins prosperity and happiness for its owners.

SIR HAROLD BOWDEN, MANAGING DIRECTOR OF THE RALEIGH CYCLE CO., LTD., NOTTINGHAM, says:—

"The Diploma of the I.C.S. in the hands of an ambitious man can carry him far, as it has carried thousands. To possess this qualification is proof of a sound, thorough, and specialised education in the subject representing that man's vocation."

The I.C.S. originated spare-time technical training by post 33 years ago, and is by far the largest institution of its kind in the world. It has teaching centres in eleven countries, and students in fifty.

Write to-day for full information as to how the I.C.S. can help you in your chosen vocation. There are 300 I.C.S. Courses, of which the following are the most important groups:—

- | | | | |
|----------------|---|----------------------------|-------------------|
| Advertising | Wireless Telegraphy (Elementary and Advanced) | Engineering (all branches) | Shorthand Writing |
| Architecture | French and Spanish | General Education | Textiles |
| Building | Commercial Training | Plumbing | Window Dressing |
| Commercial Art | Draughtsmanship | Professional Exams. | Woodworking |

International Correspondence Schools, Ltd.,
94, International Buildings, Kingsway, London, W.C.2

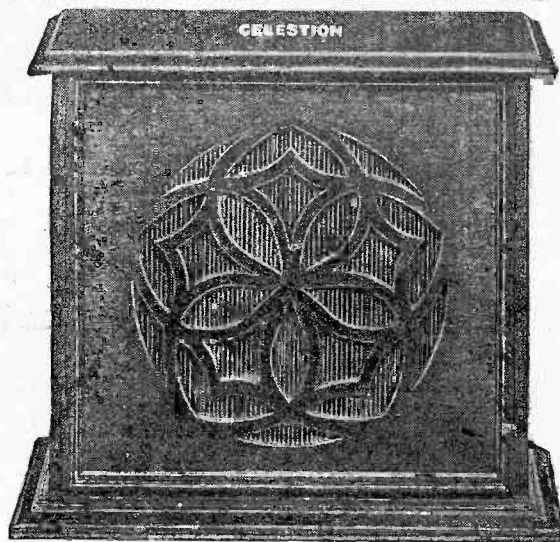

A LOUD-SPEAKER WITHOUT DISTORTION

One of the most natural tone Loud-Speakers on the market, and worked in conjunction with our "BIG BEN" 3-Valve Set the results are perfect. It has no Trumpet. It fits in any corner of the room without being noticed. The retail price in Mahogany or Oak is £8/10/0.

The "BIG BEN" 3-Valve Set complete with 1 B.T.H. "B6" Power Valve, 2 B.T.H. "B5" Valves, 1 100v. H.T. Battery, 1 4v. 80 amp. Accumulator, 1 pr. Siemens Phones, Aerial, Insulators and "CELESTION" Loud-Speaker, retail price £28/7/0.

Arrange a demonstration at your local Dealer's. If he cannot supply, instruct him to write to us, or write direct to:—

STOCKALL, MARPLES & CO. (1912), Ltd.
8/10, CLERKENWELL ROAD, E.C.1.

Telephone: Clerkenwell 6345/6. Telegrams: Stockalls, Smiths, London.

TROLITE
MOULDINGS
AND
PANELS DE LUXE

THE WORLD'S BEST - EX STOCK

F. A. HUGHES & CO. LTD.
204-206, Ct. Portland Street, London, W.1

FLAWLESS DETECTION AT LAST

The New Model
'Hovimo' Crystal Valve

Price $3/6$ each
from dealers or post free direct.

EVERY ONE
GUARANTEED.

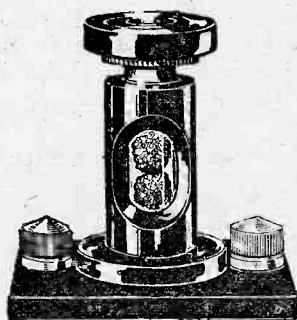

Replace Old-Fashioned 'MYSTERY' DETECTORS by the new model 'HOVIMO' CRYSTAL VALVE

The new model "Hovimo" Crystal valve illustrated below embodies a number of new and exclusive features, one of the most revolutionary of which is the fact that the whole contents of the detector are visible. Thus you are not buying a mystery. You can see exactly what you are purchasing, and, more important still, you can see exactly what you are doing when adjusting the detector.

The new "Hovimo" model can be adjusted to any set simply by first releasing the crystals and then tightening them up again, while listening for, and until obtaining, the best results.

Of course, the finer the pressure the better these results will be. And that is where the new model scores. Adjustment is made through a micro-meter screw, which acts on a spring placed over the crystal. This allows infinitely small variations of pressure to be made, with the result that absolutely flawless reception can be obtained. The above method also makes it practically impossible to crush the crystals by over pressure.

A unique feature in the manufacture of the "Hovimo" Crystal Valve is that only loose crystals of a special kind and quality are used, with the consequence that practically all handling is avoided, and the crystals retain their original sensitiveness absolutely unimpaired. Fastening of the crystals, as in the case of many ordinary detectors, involves the use of heat and consequently impairs their sensitiveness.

The new model Hovimo Crystal Valve is equally excellent for crystal sets and for circuits employing crystal rectification. It is specially recommended for the S.T. 100. No batteries required. British made.

M. MOLBACK, 27, High Holborn, London, W.C. 1
Telephone, Chancery 8391.



LOUD SPEAKERS.

TOM-TIT
2000 ohms $30/-$
Black Crystalline
or Bright Stove
Enamel.
JUNIOR.
2000 ohms $55/-$
STANDARD
120 ohms $£4$ 15 0
2000 ohms $£5$ 0 0
4000 ohms $£5$ 10 0
Black Crystalline
or Black Satin
Enamel.

The initials that
stand for the
highest class of
DESIGN
WORKMANSHIP
& FINISH.

Transformer,
L.F.
For the first and
second stages of
amplification $27/6$
5:50 High Ratio
for first stage.
5:15 Low Ratio
for second stage.
C.A.V.
Accumulators.
for wireless are
the result of 32
years' manufactur-
ing experience

Write for catalogue of Loudspeakers,
Transformers, and Wireless Accu-
mulators.

C.A. Vandervell & Co. Ltd.
ACTON VALE, LONDON, W. 3.

100% EFFICIENCY H.T. BATTERY. CONSTRUCTORS' IDEAL.



See Apparatus Tested, April, 1924. Why buy inefficient tiny sealed-in batteries? I offer Terminalled Giant Unit Dry Cells, 1 1/2 volts of 300 per cent. more capacity. See Photo. Cells, 4/- doz., plus carriage. 60 volt type in polished Oak Case as reported, 19/6, carriage 1/9. In cart box 14/6. Every cell replaceable. Lists free. Sample Cell, 6d. 9 Volt Grid Battery, 2/6. Money back guarantee. Prompt delivery guaranteed. Direct only from Sole Maker:
FINGHETT (C.A.) Old Armoury, Oswestry.

For advertisement rates of the Radio Press Publications — "Modern Wireless," "Wireless Weekly," "The Wireless Constructor" — apply to the Advertisement Manager:—

BARCLAYS ADVERTISING Ltd.,
Bush House, Strand,
LONDON, W.C.2.

Telephone: City 9911.

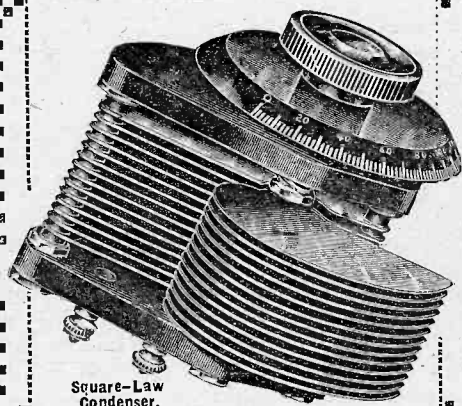

Square-Law
Condenser.

A NEW SQUARE-LAW CONDENSER

The Essential features of the Square-Law Type of Condenser are well known, but accuracy in manufacture is doubly essential to maintain their straight-line characteristics.

Capacities .001, .0005, .0003 and .0005 mfd.
With Vernier .001, .0005, .0003 and .00025 mfd.
Ask your wireless dealer to show you the whole series of



ONE-HOLE-FIXING COMPONENTS

Wholesale only:
FALK, STADELMANN & CO., LTD., Efesca Electrical Works,
83-85-87, Farringdon Road, LONDON, E.C.1

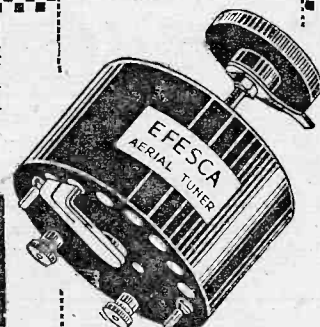

Efesca Tapped Aerial Tuner.
Wave-length range 150-2,600 metres in conjunction with .001 condenser. Price 19/- Incorporating studs and tapping Switch

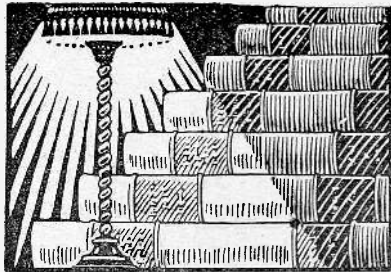

THE BOOKS

for Beginners
and Experts

WITHOUT a doubt the very remarkable growth in the number of home-built Receiving Sets can be attributed to the exceptional Books and Magazines published by Radio Press, Ltd. This organisation—the largest of its kind in the world—has risen from quite modest beginnings because it was the first to realise that the crying need then, as now, was for dependable literature.

The moment a man gets really interested in Radio he is so fascinated that he immediately wants to learn more about it. Naturally he buys books and magazines—but let those books or magazines be too technical that he cannot understand and appreciate them, or let them contain inaccuracies or mis-statements and Radio loses another promising recruit.

Radio Press, Ltd., pursues a definite policy in its book publishing, which can be summed up as follows:—

(a) It publishes Books written only by authors of repute. Its Editorial Staff—both in number and in experience the strongest in the country—is well able to check every manuscript submitted and to supervise generally the publication of every Book.

(b) Each Book selected for publication must fill a definite niche in the Radio Press Series. Just as there are many grades of wireless enthusiasts from novices to experienced experimenters, so there must be various types of Radio Press Books. At the same time, however, every phase of the Science is covered so thoroughly that anyone can build up a complete library as his knowledge increases.

(c) Every Radio Press Book is printed in good style, profusely illustrated and represents particularly good value for money. While several of the more elementary ones are published at a cheaper price, the bulk of the Radio Press Series cost 2/6 each. This price permits a very high quality being maintained and allows half-tone illustrations and, in the case of the constructional books, the fullest descriptions being given of every stage of Set building.

Make up your mind to look through the whole series at your Bookseller's or Wireless Dealer's—he has them in stock or will get them for you. It will be your first step to increased proficiency.

All Radio Press publications can be obtained from any Newsagent, Bookseller, or from local wireless dealer, or direct from the Publishers.

Complete List (M) Free on Application.

Radio Press Ltd.,
Bush House, Strand, London, W.C.2

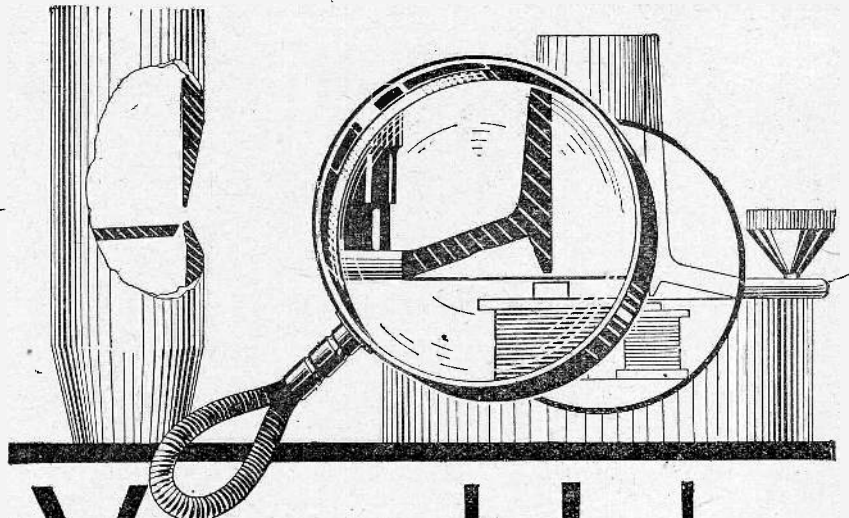

Voiced Like an Organ

The voice is in
the mouth of
the horn, NOT
in the box.

FOR true reproduction a Loud Speaker should amplify the vibrations of the diaphragm. It should not add any harmonics, or take any away.

In certain types of organ pipes it is necessary to produce the **pure fundamental tones**. The lip of the pipe is the place where the voicer's art is applied to obtain this result. The lip of the Loud Speaker is the part which has to be considered for fine reproduction. You appreciate MUSIC. You will appreciate the **RADIOSUN**. In sunlit mahogany finish Price £5.

Write for leaflet describing the Wonderful Difference, and ask your dealer to arrange with us for a demonstration.

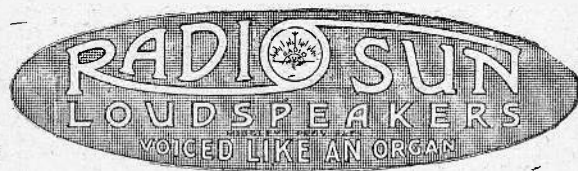

AUTO SUNDRIES LTD.,
10, LOWER GROSVENOR PLACE, LONDON, S.W.1.

In replying to advertisers, use Order Form enclosed.

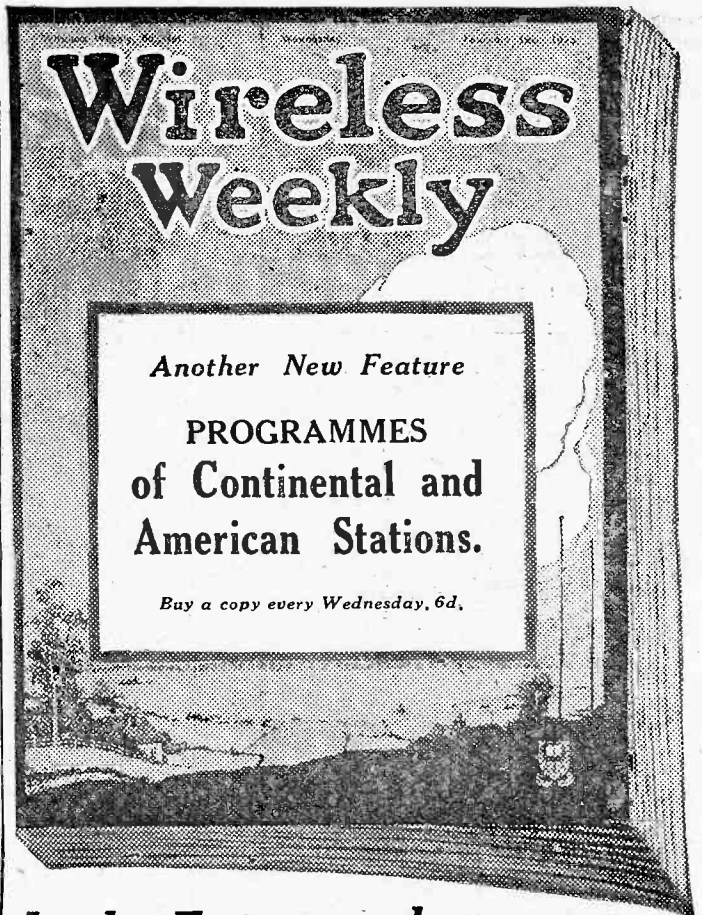

Another New Feature
PROGRAMMES
 of Continental and
 American Stations.

Buy a copy every Wednesday, 6d.

A Radio Easter for me!

SOME OF THE CONTENTS OF THE APRIL NUMBER

- "How to make a Powerful 3-Valve Set."
- By PERCY W. HARRIS, M.I.R.E.
- "How to make a Choke Coupled Amplifier."
- By JOHN W. BANNER.
- "Look after Your Telephone."
- An article of great value to every reader.
- By STANLEY G. RAFFER, M.I.R.E.
- "How to make a 2-Valve Amplifier for the 'Stay Set' Crystal Set described in the last issue."
- By D. J. S. HART, B.Sc.
- "How to make a Single Valve Short Wave Set."
- By C. P. ALLINSON.
- "How to make a Loose Coupled Crystal Set."
- "The Editor at SLO."
- Many other articles, hints and tips, and more humour describing how "Mr. Gumblethorpe Gets On," by BROADCASTER.

A Free Blue Print is given with every Copy.

I'M going to get out my April "Wireless Constructor" and settle down to a glorious holiday building one of the radio receivers it tells so simply how to make. It's going to be a wonderful time for me. First the deep interest in the construction, then the glorious sense of achievement when I first tune in signals, and after that the full and complete enjoyment of all that radio brings. Take a tip from me, get a copy of "The Wireless Constructor" and spend your happiest Easter making one of the many sets it describes.

In the Foreground

—as is customary

The "Wireless Weekly" again fully maintains its reputation as the leading organ in wireless by the introduction and regular publication of Continental and American Broadcasting Programmes—in advance. This new feature, which first appeared in our issue of March 4th, will be regularly included in the form of a supplement, and elaborate arrangements have been concluded whereby accurate and detailed times of **CONTINENTAL AND AMERICAN BROADCASTING PROGRAMMES** for the coming week will be given, together with names of artists, the songs and music rendered and other fascinating particulars. The inclusion of this novel and attractive feature will still further enhance the vast popularity of this great weekly wireless journal. Start reading it yourself.

The Wireless Constructor

Obtainable from all Bookstalls,
 Newsagents and Booksellers,
 Subscription Rate 8/6 per year post free.

6^d
 MONTHLY

ADVT. OF RADIO PRESS LTD., BUSH HOUSE, STRAND, W.C.2.

Wireless Weekly

6d. Every Wednesday. 6d.

Edited by John Scott-Taggart, F.Inst.P., A.M.I.E.E., so well known for the many original and popular circuits which are described only in Radio Press publications—*Wireless Weekly, Modern Wireless, The Wireless Constructor*—of which he is the Editor-in-Chief. Published by Radio Press, Ltd., Bush House, Strand, London, W.C. 2.

Barclays 912

Barclays Ad.

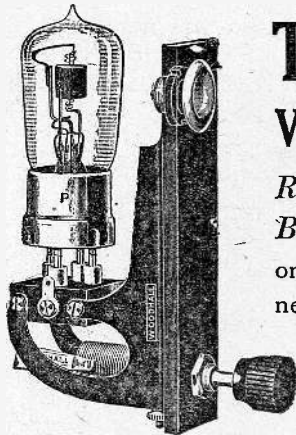

The Woodhall Valve unit combines Rheostat, Valve Holder, Bracket and Window, in one compact fitting. And you need to drill *two holes only*.

This newest addition to the Woodhall Range of Components fills a definite need of many 'home constructors.' It gives the popular 'back of panel' fitting for the valve, occupies a minimum of space, and is highly efficient in use.

Consists of Woodhall Valve Holder, on rigid bracket, with nickel-plated valve window and Woodhall Vernier Rheostat (see below). The **WOODHALL Vernier Rheostat** (Pat. No. 213,030). Combined plunger and rotary movement. Push-pull movement for coarse setting; rotary for vernier. Wonderfully smooth movement; best ebonite former; one-hole fixing. 6 ohms, 2/6; 10 or 12 ohms, 3/-; 30 ohms, 3/6.

PRICE (complete):
With 6 ohms Rheostat 6/6
With 10 ohms Rheostat 7/-
With 30 ohms Rheostat 7/6

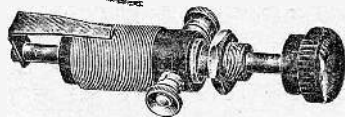

WOODHALL

Guaranteed Components

Sold by all the best Radio Dealers. Sole Distributors:

Pressland Electric Supplies, Ltd., HAMPTON-ON-THAMES.

Phone: Molesey 22.



T. O. BUSS

SCIENTIFIC INSTRUMENT MAKER

77, Clerkenwell Rd., London, E.C.1

Estb. 1850. Exhibition Awards: London, 1862; Sydney, 1879; Melbourne, 1880.

INTERVALVE TRANSFORMERS

Made like an Instrument by a Scientific Instrument Maker.



Correct priming impedance. Wound with correct gauge and quantity of wire. Heavy iron core to give good magnetic field—and will carry heavy currents.

PRICE 18/6

Ratio 5 to 1.

MADE LIKE AN INSTRUMENT.

This instrument is thoroughly tested and is **GUARANTEED FOR TWO YEARS.**

Barclays 553

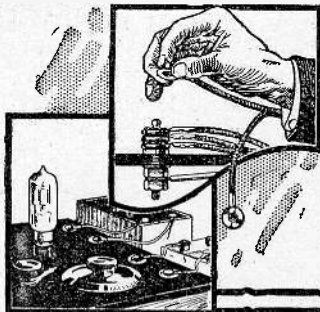

Divide the time by Ten

CONTENTS OF COMPLETE BOX.

- 8 Terminal Studs.
- 6 Multi-Connectors.
- 4 Coloured Connectors.
- 8 Discs (Black, Red and Blue).
- Phones +
- Phones -
- High Tension +
- High Tension -
- Low Tension +
- Low Tension -
- Earth.
- Aerial.

Complete with instructions.

PRICE 2/-

EXPERIMENTERS! How long does it usually take to wire-up an experimental circuit, using a soldering iron? And the possibility of several alterations being undertaken to ensure the best results. Before you lose enthusiasm build a circuit with Newey Snap Terminals. They take the worry out of wireless. Just the slightest pressure of a finger and there is perfect vibrationless contact wherever they are placed. For headphone connections, high-tension, low-tension, aerial, earth and all other terminals, Newey Snap Terminals ensure perfect reception. Every wireless enthusiast wants these terminals.

All Wireless Dealers stock Newey Snap Terminals. Complete sets can be had or the various parts described can be obtained separately for use on existing sets.

PETTIGREW & MERRIMAN
124, TOOLEY ST. LONDON, E.C.1.

FOR WIRELESS PHONE AND BATTERY CONNECTION



MADE IN ENGLAND - PATENT NO. 14130/24

In replying to advertisers, use Order Form enclosed.

CLARKE'S ATLAS FILAMENT CONTROL

Patents Pending

Works on an entirely new principle. No wires to scrape and scratch. No powder to cause troublesome "packing."

Gives astoundingly easy control of bright or dull emitters—a marvel of noiseless efficiency.

Economises current; lengthens the life of your valves, and is a deciding factor in bringing in those elusive stations. 50 ohms resistance. One-hole fixing.

Sole Manufacturers:

H. CLARKE & CO. (Mcr.) LTD.,
Atlas Works, Old Trafford, MANCHESTER
'Phones: 683 and 793 Trafford Park. 'Grams: "Prtoid, Manchester"



Price 6/6 each
From all good dealers.

TWO EFFICIENT SINGLE VALVE SETS

By Herbert K. Simpson.

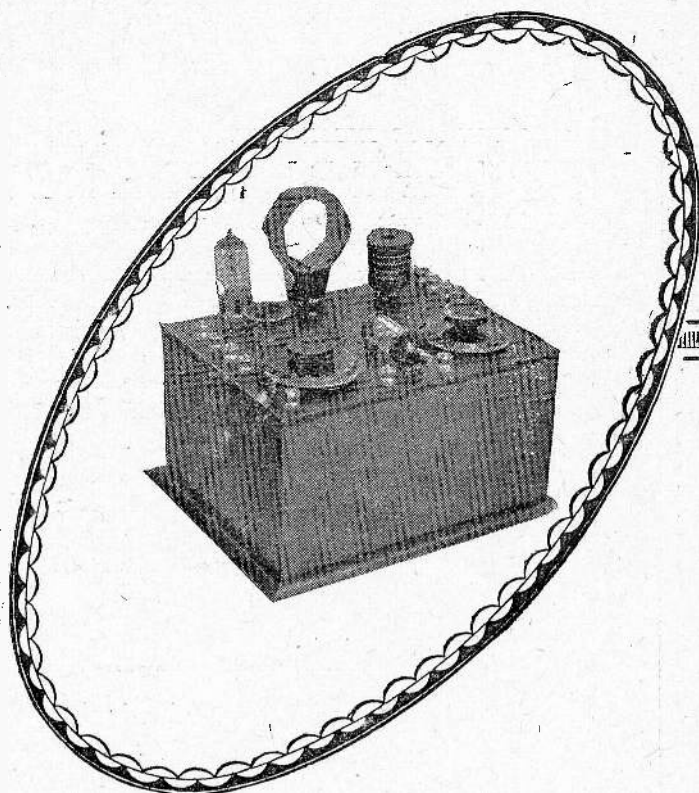

LOUD-SPEAKING WITH ONE VALVE.

Radio Press Envelope M.8 SINGLE VALVE REFLEX SET

In this set the valve functions in a dual capacity amplifying first at high frequency, and then again at low frequency. At short distances from a B.B.C. Station it will therefore work a loud-speaker with sufficient volume for a small room if an outside aerial is used. Strong headphon signals can be obtained up to much longer distances.

UNIVERSAL WAVELENGTH RANGE

Order these envelopes
to-day, 1/6 each or
post free 1/9.

THE IDEAL BEGINNER'S SET.

Radio Press Envelope M.9. SINGLE VALVE RECEIVER

This set is so easy to build and so simple to work that it forms a perfect starting point for the novice. With an outside aerial a little practice will enable quite a number of the B.B.C. and Continental stations to be received with ease. A dull emitter valve can be used without any alterations.

Will receive 5XX practically anywhere in Great Britain.

These envelopes contain full and elaborate sheets of instructions, two full-size blue prints, three sheets of photographs on art paper and a sheet of working drawings, clearly showing how to make the sets here described.

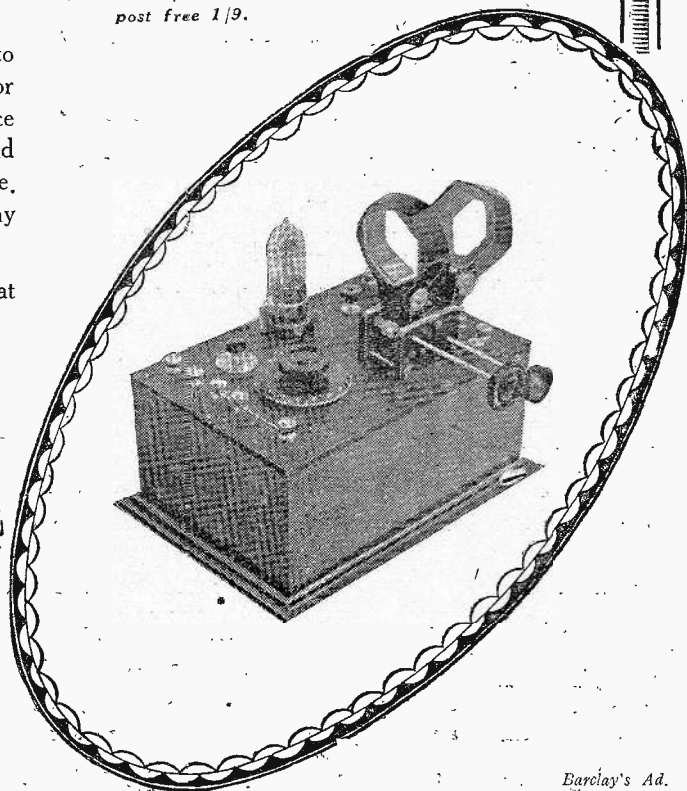

Obtainable from book sellers and wireless dealers, or direct from (Dept. M.):

Radio Press, Ltd.

The largest wireless publishers in the world,

Bush House, Strand, London, W.C.2

Barclay's Ad.

**HERE'S THE SECRET
OF SUCCESSFUL H.F. AMPLIFICATION**

**AT LAST!
WITH THE**

**STRADIO
VARIABLE CORE
H.F. TRANSFORMER**

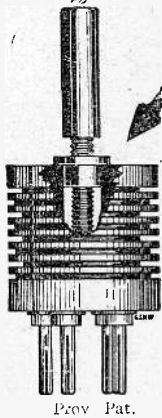

This device

1. Increases selectivity 100 per cent.
2. Enables absolute matching.
3. Eliminates self-oscillation.
4. Gives complete control any number of stages of H.F.
5. **GIVES YOU THAT DISTANT FEELING.**

9/-

9/-

May be obtained from any good dealer or in case of difficulty direct from:—

STIRLINGS LIMITED,
17, Clarence Street,
Kingston-on-Thames

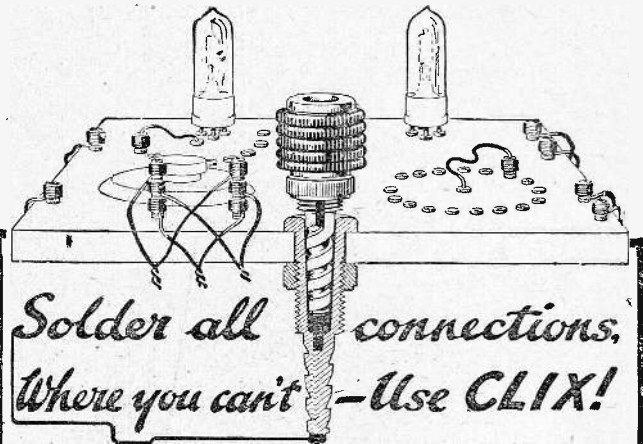

CLIX PROVIDES AN IDEAL POINT FOR SOLDERING

Perfect contact — instantly—everywhere.

The tapered design of CLIX plug-socket ensures full surface contact in every one of its countless applications.

Retail Prices

CLIX with Lock-nut, 3d.

CLIX Insulators (6 colours) 1d. each.

CLIX Bushes (6-colours) 1d. per pair.

That's why CLIX supercedes all forms of Plugs, Terminals, and Switches, and has standardised the wiring of all radio circuits.



Magic Music from the Skies
- the GIL-RAY brings it
out in all its Purity of Tone

READ THIS :

Royal College of Science.

DEAR SIRS,

It may interest you to know that I have recently scientifically tested your "GIL-RAY" Crystal. Its performance was truly extraordinary when tested both electrically and on a Crystal Set.

From its characteristic curves it would appear to be particularly useful in Reflex Circuits. Yours truly, L.C., D.I.C., A.I.C., etc.

PRICE 1/6 of dealers everywhere. If unobtainable, please forward 1/6 and name and address of dealer to the producers:—

GIL-RAY Trading Corporation, 35, Sicilian House, Sicilian Avenue, London, W.C.1.

Phones: MUSEUM 3206 (3 lines). Grams: "GILRAYTRAD, WESTCENT, LONDON."

OUR GUARANTEE.—While every "GIL-RAY" Crystal is tested before being packed we will gladly replace any faulty Crystal, free of charge, if returned to address shown.

*The
Crystal
of the
Age!*

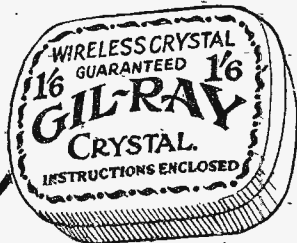

TRADE ENQUIRES SOLICITED.

CLIX

The Electro-Link with 159 Uses

Obtainable from all Wireless Dealers or direct from the Patentees and Manufacturers:

AUTOVEYORS LIMITED

Radio Engineers and Contractors

84 VICTORIA STREET, LONDON, S.W.1

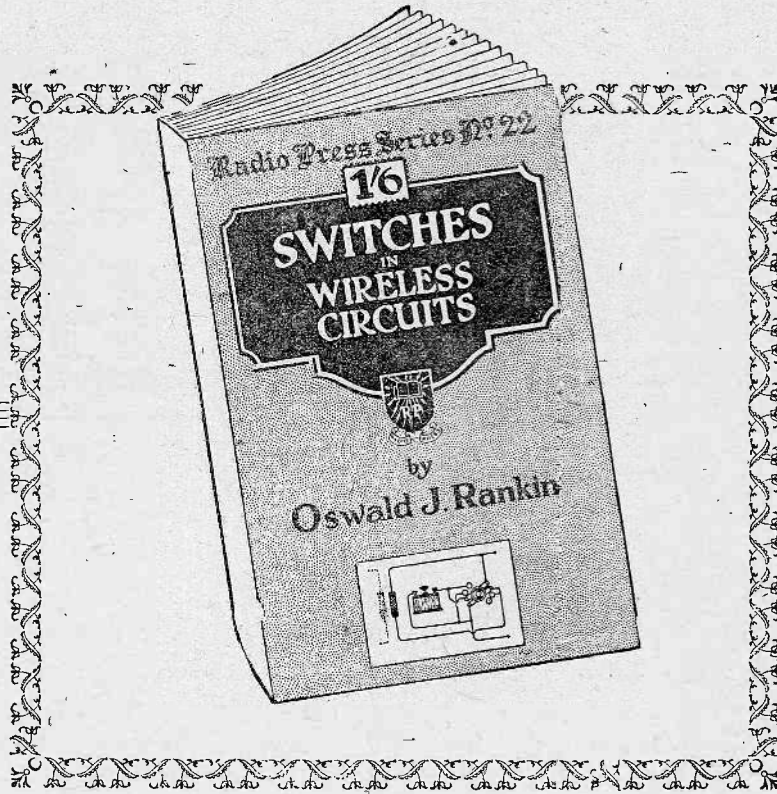

“To Switch or not to switch!”

The complex problem of deciding whether or no a certain circuit or component should be switched, and the best method to adopt when the answer affirms the question, is the subject of an attractive book by Oswald J. Rankin entitled “Switches in Wireless Circuits.”

This is one of the latest additions to the series of authoritative books on wireless, published by Radio Press, Ltd., and like its predecessors is written in an accurate, yet perfectly readable manner. Profusely illustrated with diagrams, shown both theoretically and pictorially, the contents give over 50 different switching arrangements covering practically every requirement.

All difficulties heretofore associated with the trouble of switching will vanish with the purchase of this book and the danger of valves burning out or possible battery damage will be completely eliminated.

Ask for the book with the distinctive yellow cover, the Radio Press Series No. M22, Price 1/6. Obtainable from all Newsagents, Booksellers, your local Wireless Dealer, or direct from the Publishers. Post free 1/8.

*When ordering be
sure and quote
—Series No. S22—*

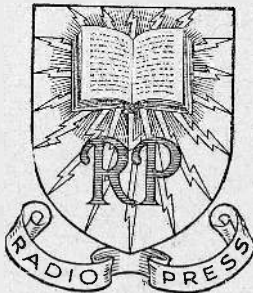

Radio Press, Ltd.
BUSH HOUSE, STRAND, LONDON, W.C.2.

HUNT'S NEW ACCESSORIES
VARIABLE GRIDLEAKS

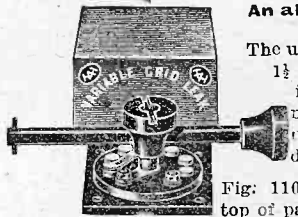

An absolute necessity for Delicate Long-Distance Tuning. The usual resistance employed by Wireless 1½ megohms, and with the "Hunt's" instruments a variation of from ½ to 5 megohms can be immediately made by turning the switch during tuning operations:

Fig. 1100: Same as Fig. 1102 but top of panel mounting.

"VARLEAK"

PRICE 4/6 EACH.

Fig. 1110. Anti-capacity handle 9d. each extra.

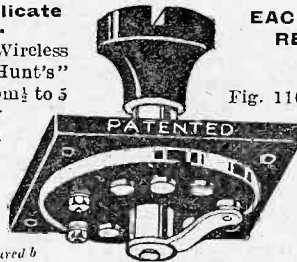

EACH STOP A DEFINITE AND REPEATABLE RESISTANCE.

"PANLEAK"

Fig. 1102: Underpanel Mounting Model is perhaps the most popular of the two models and is adaptable up to a ⅜ in. panel:

PRICE 5/- EACH.

Complete as illustrated: Standard calibration ½-5 megohms or to order:

Fig. 970: "HOLDER."

Valveholder complete as illustrated 1/3 each.



Fig. 970.

Manufactured by

A. H. HUNT, LTD.
(Dept. 5), H.A.H. WORKS, TUNSTALL ROAD.

CROYDON.

Wireless List "F" Post Free

Price **10/6**

Postage 6d.



A most efficient device to which ordinary headphones are clipped by simple pressure on the spring clips.

The **"Gramaphix" Loud-Speaker**

The Gramaphix requires (according to distance from the Broadcasting Station) at least one stage of low-frequency amplification to give satisfactory volume.

HORNS TO MOUNT ON GRAMAPHIX:
Straight Horn (Bell 10 in.) 6/-.
Swan-necked Horn (Bell 11½ in.) 15/-.
Small Curved Horn (Bell 8½ in.) 7/6. Post 9d. extra.

Richard Melhuish, Ltd.,
50/51 & 84 Fetter Lane, London, E.C.4
Electrical Engineers and Wireless Experts, Est. 1828

"Megger" evidence

YOU can't tell how good—or how bad—a piece of ebonite is by looking at it. Even its surface appearance can belie its actual efficiency. But build it into a set—particularly if you are using a stage of High Frequency amplification—and you will soon find out whether its quality is good. Now obviously, you don't want to go to the trouble and expense of building a good Set only to find that the signals are weak—or that the Set howls—or even that not a sound is obtainable. What is the remedy? Use a Red Triangle guaranteed Panel and success is assured.

Every sheet of Red Triangle ebonite before being cut into panels is tested on the Megger—a wonderfully sensitive electrical instrument which instantly detects leaks. Nothing can escape its eagle eye and any ebonite that does not come up to the Red Triangle standard of quality is ruthlessly cast out. Each panel is cut dead square and is supplied with a velvet matt surface carefully packed under our own label.

Special Radio Press Sizes:

All Concert-de-Luxe, 16 x 8 x ½	8/-	Resistorlex, 12 x 8 x ½	8/-
Transatlantic V., 22 x 11 x ½	15/-	Anglo-American, 36 x 9 x ½	20/-
All Britain, 16 x 9 x ½	9/-	Neutrodyn e Tuner, 12 x 10 x ½	7/6
S.T. 100, 12½ x 9½ x ½	7/-	Neutrodyn e Receiver, 12 x 10 x ½	7/6
Purilux, 14 x 10½ x ½	9/2	3-Valve Dual, 24 x 10 x ½	15/-
Transatlantic IV., 16 x 8 x ½	8/-	Harris Crystal Set, 9 x 5½ x ½	4/4

Any Special Size Cut per return at ¼d. per square inch.

Use **PETO-SCOTT CO., LTD.,**
Registered Offices, Mail Order & Showrooms,
77, CITY RD., LONDON, E.C.1

BRANCHES:
LONDON:—62, High Holborn, W.C.1.
WALTHAMSTOW:—230, Wood Street.
PLYMOUTH:—4, Bank of England Place.
LIVERPOOL:—4, Manchester Street.
CARDIFF:—94, Queen Street.

Red Triangle Ebonite

P.S. 2210

THIS IMPROVED **Athol** MEANS INSULATION

REVERSIBLE VALVE HOLDER
SPECIALLY SUITABLE FOR **Baseboard Mounting**
AND CAN BE USED BACK or FRONT of VERTICAL and HORIZONTAL PANELS.

We will send goods post free if you mention dealer's name

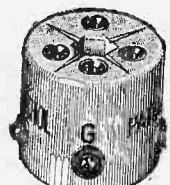

1/3 EACH
LISTS FREE.

Athol ENGINEERING CO
CORNET STREET, H. BROUGHTON, MANCHESTER

PURITY of TONE

and volume can only be secured by using L.F. Transformers which give high amplification without distortion.



The "HERALD" is built and designed to give these results. Sold by all Dealers under our 30 days' test guarantee. Money refunded if our claims are not substantiated.

Price 12/6. Send 3d. for complete Components Catalogue.

Trade should write for full range of Radiax Sets and Components.

RADIAX REACTANCE UNIT

Instantly fixed to any panel—3 coils cover the range from 100 to 4,000 metres.

No. 736 with coil, 300/1,600 metres, 6/9.

Extra coil for 100/300, 3/3.

Extra coil for 1,600/4,000, 3/9.



THE APEX SUPER CRYSTAL

The guarantee of THIS Crystal is that we use it in our own Receivers on account of its remarkable power, permanence and long life. Price 1/3 per tin, with spearpoint catswhisker.

RADIAX, LTD. 40, Radio House, Percy St. Tottenham Court Road, London, W.1.

3 minutes from Tottenham Court Road and Goodle Street Tube Stations.

RADIAX
WE SATISFY YOU
Barclays 904

In replying to advertisers, use Order Form enclosed.



The Finishing Touch!

Apply the finishing touch to your set by attaching to the panel "Radio Press Wireless Panel Transfers" (sold in large packets of over 80 labels).

They are neat, permanent, and fully up to the high standard maintained by Radio Press, while they impart that 'professional look' to every set on which they appear.

Always used by the Radio Press staff for their own sets—sure proof that they are ideal for your requirements. They are the cheapest also.

Buy a packet or two from your local wireless dealer, or bookseller, but be sure you get what you want.

"Radio Press" Wireless Panel Transfers 6d. per packet or 8d. post free direct from—

DEPT. M.,

Radio Press, Ltd.,
BUSH HOUSE,
STRAND, LONDON, W.C.2.

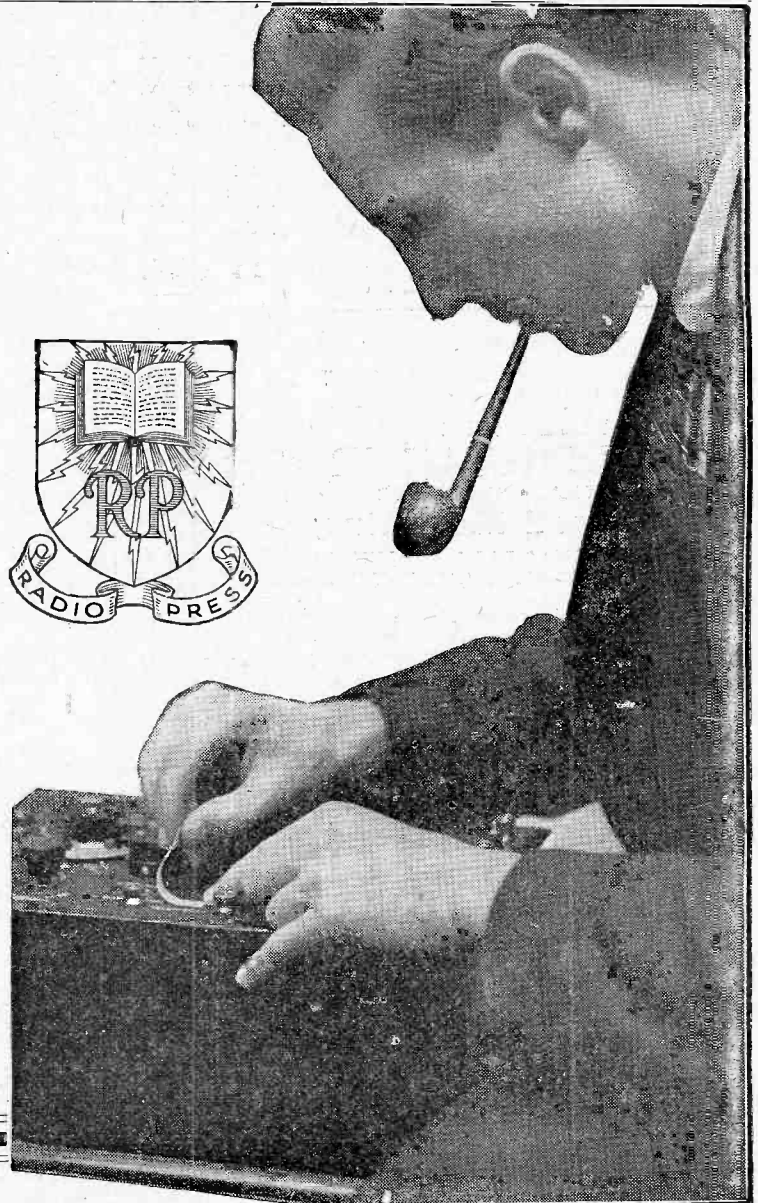
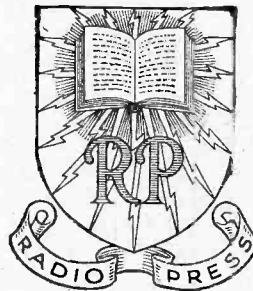

Barclay's Advt.

Perfectly simple and simply perfect

THE MIC-MET SUPER CRYSTAL DETECTOR

[REGD.] (PATENT NO. 221943.)

This instrument is micrometrical in principle and ensures a perfectly adjusted and rigid contact between crystal and contactor. By a combination of movements between the three knobs, any portion of the exposed part of the crystal may be contacted. For S.T. 100 and other circuits employing crystal rectification, the most efficient detector to use is the MIC-MET. Can be obtained from your local wireless dealer or direct from the manufacturers on receipt of 6s. P.O. Trade enquiries solicited.

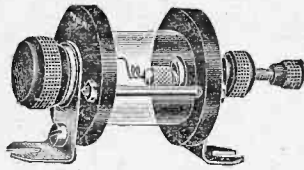

British Make.

Beware of imitations and infringements.

C. & J. ARRIGONI & CO., LTD., COMPTON PASSAGE, CLERKENWELL, LONDON, E.C.

Don't tickle the Crystal—use

Harlie FOOL-PROOF DETECTOR

Provisional Patent 2679124

Continuous reception in any position at all times, owing to the special design of both crystal and catwhisker, always in contact.

GUARANTEED TONE—VOLUME—PURITY

Some Novel Features:—

1. Nickel-plated detachable dust-proof cover.
2. Special "Harlie" super-sensitive crystal.
3. Ebonite wheel for rotating crystals.
4. Catwhisker on slider for covering whole surface of crystal.
5. Nickel-plated sockets for panel mounting.

Obtainable from all dealers or direct from patentees and mfrs.

PRICE COMPLETE 5/6

Generous Trade Terms. Telephone Clissold 293.

HARLIE BROS., 183, Dalston Lane, HACKNEY, London, E.8.

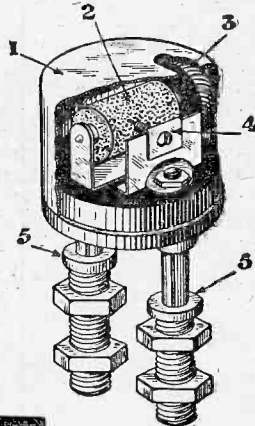

Barclays 892

ANNOUNCING

The Famous Precise Super Multiformer.

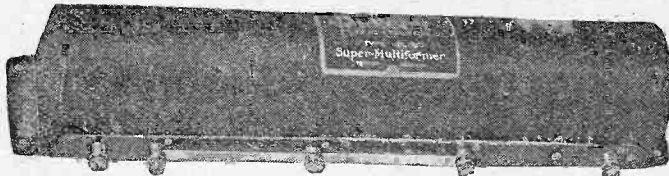

One Instrument which does the work of four in all Superheterodyne Sets.

Replaces all long wave transformers in any type or modification of the Superheterodyne circuit. This instrument has met with the unanimous approval of noted radio experts and is already demanded by the public, which is rapidly learning of its superiority over the conventional type of Superheterodyne transformers. It cuts in half the time and eliminates all trouble in building a Superheterodyne and insures the builder of successful results due to the short connections which are required from the instrument to the respective valve sockets, thus preventing the experimenter from unconsciously causing undesirable coupling between circuits.

PRICE £4 17 6



"REGAL" GUARANTEED COMPONENTS.

Used as Standard Equipment by Leading Set Manufacturers.

12-point no end loss	No. 120, 6 ohms Vernier	6/-	
Inductance Switch,	30	6/-	L.F. Transformer, 3 1/2
Price .. 6/6	No. 130 6 "	5/-	to 1, wonderful
	30 "	5/-	tone .. 18/6

N.B.—All our products are fully tested and guaranteed by our principal, C. G. Vokes, A.M.I.Mech.E., etc.

C. G. VOKES & COMPANY, 38, Conduit Street, Regent Street, W.1. Telephone: Gerrard 4693.

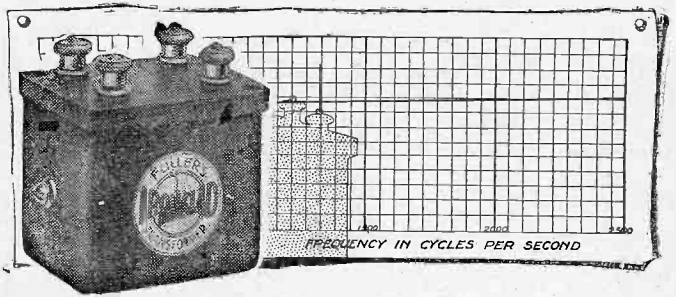

What an amplification characteristic curve shows

When an artiste sings a note or an instrument is played, the quality of the tone depends upon the proportion in which the "natural harmonics" of that tone are present. Middle C, for example, has a frequency of 512, and the natural harmonic one octave higher has a frequency of 1,024. Thus, the fidelity of reproduction of the singer's note depends on the evenness with which all the harmonics present in that particular tone are amplified in the receiving set.

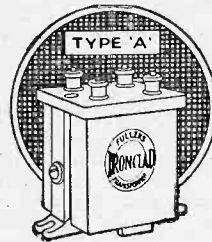

Type "A" Intervalve.

Ratio 1—5.

Size 2 x 2 1/4 x 2 3/8 ins.

Price 20/-

Type "TA" Telephone.

Ratio 1—10.

Price 18/-

Glance at the characteristic curve of the Type "B" Ironclad Transformer—note the flatness throughout practically the whole range of audible harmonics. This shows why its amplification is so extraordinarily natural.

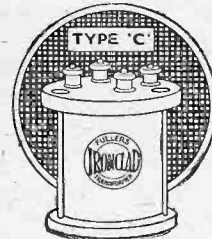

Type "C" Intervalve.

Ratio 1—4.

Size 2 7/8 ins. diameter x 2 1/2 ins. deep.

Recommended for Power Amplifiers.

Price 24/-

Type "TC" Telephone.

Price 24/-

Then there are all manner of constructional refinements. It is completely enclosed mechanically and screened magnetically, preventing inter-action. Layer-wound, moisture proof, spaced coils are employed, which, in conjunction with the special form of insulation, successfully prevents turns becoming loose.

For the music-lover, for the man who is only satisfied with reproduction in all the purity of its original rendering, there can only be one amplifying instrument—the "Sparta" Ironclad Transformer.

Type "B" Intervalve.

Ratio 1—4. Size 2 x 2 3/8 x 2 1/2 ins. Recommended for Power Amplifiers.

24/-

Type "TB" Telephone for Loud Speakers

23/-

SPARTA IRONCLAD TRANSFORMERS

FULLER'S UNITED ELECTRIC WORKS, LTD. WOODLAND WORKS, CHADWELL HEATH, ESSEX

In replying to advertisers, use Order Form enclosed.

The Progressive Method to Wireless Proficiency

"SIX SIMPLE SETS"

By STANLEY G. RATTEE, M.I.R.E.

This new Radio Press publication fulfils a definite requirement of the radio public and constitutes a graded course of instruction in the making of Wireless Receivers.

Every one of the six sets described has been built by the author himself, and each is guaranteed to give efficient results if instructions for building are followed accurately.

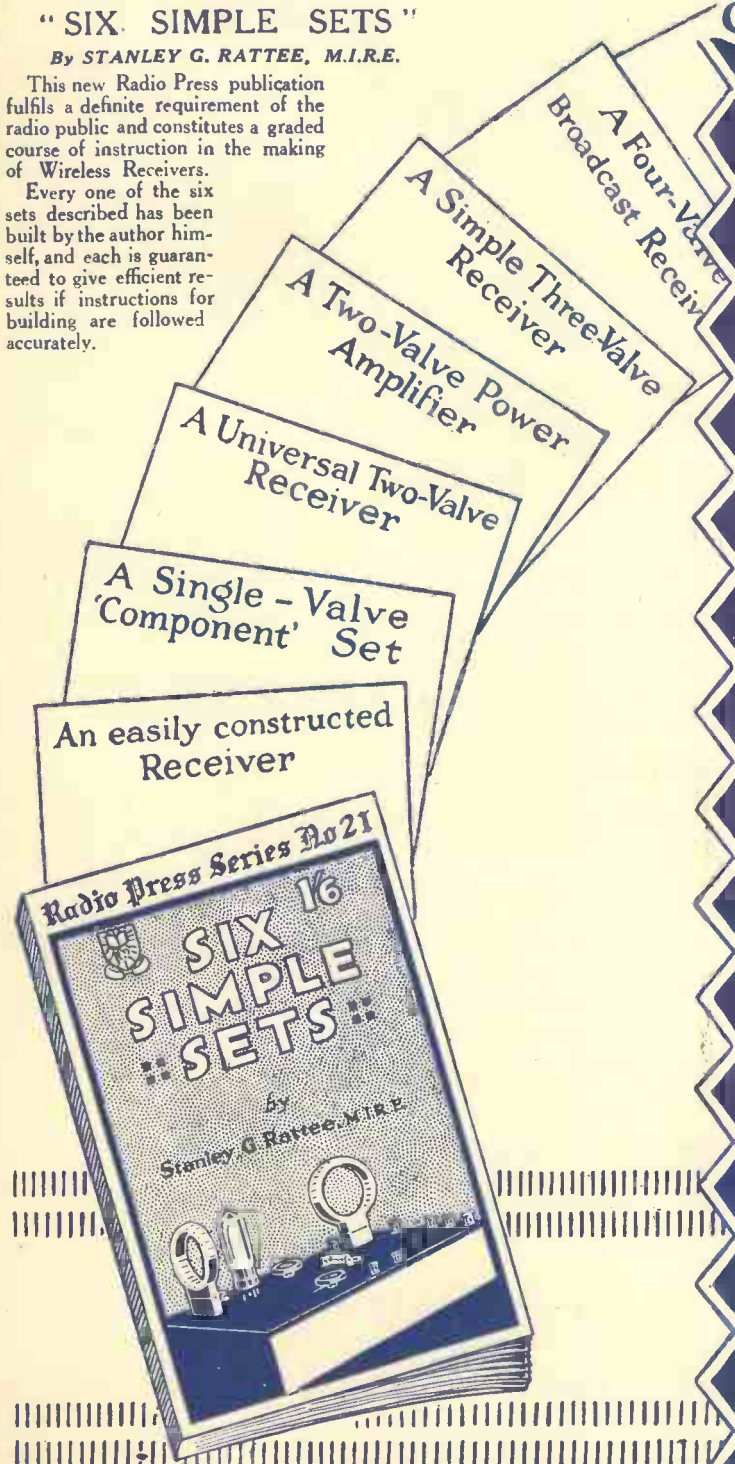

The Radio Press Series of Books, Envelopes, etc.

- 21 Six Simple Sets. By Stanley G. Ratee, Member I.R.E. ... 1/6
 1 Wireless for All ... 9d.
 By John Scott-Taggart, F.Inst.P., A.M.I.E.E.
 2 Simplified Wireless ... 1/-
 By John Scott-Taggart, F.Inst.P., A.M.I.E.E.
 3 How to Make Your Own Broadcast Receiver ... 1/6
 By John Scott-Taggart, F.Inst.P., A.M.I.E.E.
 4 How to Erect Your Wireless Aerial ... 1/-
 By B. Mittell, A.M.I.E.E.
 5 The Construction of Wireless Receiving Apparatus ... 1/6
 By P. D. Tyers
 6 The Construction of Crystal Receivers ... 1/6
 By Alan L. M. Douglas.
 7 How to Make a "Unit" Wireless Receiver ... 2/6
 By E. Redpath
 8 Pictorial Wireless Circuits ... 1/6
 By Oswald J. Rankin.
 9 Wireless Valves Simply Explained... 2/6
 By John Scott-Taggart, F.Inst.P., A.M.I.E.E.
 10 Practical Wireless Valve Circuits ... 2/6
 By John Scott-Taggart, F.Inst.P., A.M.I.E.E.
 12 Radio Valves and How to Use Them ... 2/6
 By John Scott-Taggart, F.Inst.P., A.M.I.E.E.
 13 500 Wireless Questions Answered ... 2/6
 By G. P. Kendall, B.Sc., and E. Redpath.
 14 12 Tested Wireless Sets ... 2/6
 By Percy W. Harris, Member I.R.E.
 15 More Practical Valve Circuits ... 3/6
 By John Scott-Taggart, F.Inst.P., A.M.I.E.E.
 16 Home-Built Wireless Components... 2/6
 17 Wireless Sets for Home Constructors ... 2/6
 By E. Redpath.
 18 Tuning Coils and How to Wind Them ... 1/6
 By G. P. Kendall, B.Sc.
 22 Switches in Wireless Circuits ... 1/6
 By Oswald J. Rankin.

Radio Press Envelopes.

- 1 How to Build an STroo Receiver ... 1/6
 By John Scott-Taggart, F.Inst.P., A.M.I.E.E.
 2 How to Build a 4-Valve Receiver ... 2/6
 By Percy W. Harris, Member I.R.E.
 3 How to Build the "Simplicity" 3-Valve Set ... 2/6
 By G. P. Kendall, B.Sc.
 4 How to Build the All-Concert de Luxe Receiver ... 2/6
 By Percy W. Harris, Member I.R.E.
 5 How to Build the Omni Receiver ... 2/6
 By John Scott-Taggart, F.Inst.P., A.M.I.E.E.
 6 How to Build the ABC Wave Trap... 1/6
 By G. P. Kendall, B.Sc.
 7 How to Build a 2-Valve Amplifier de Luxe ... 1/6
 By Herbert K. Simpson
 8 How to Make a 1-Valve Reflex Receiver ... 1/6
 By Herbert K. Simpson
 9 How to Build an Efficient Single-Valve Set ... 1/6
 By Herbert K. Simpson

The Radio Press Envelopes are the most complete guide to wireless construction ever devised. Every possible detail is explained and you cannot go wrong.

All the above can be obtained from wireless dealers, booksellers—or direct (plus 2d. postage on books and 3d. on envelopes) from Dept. M.

Radio Press, Ltd.

Bush House, Strand, W.C.2.

The
Secret

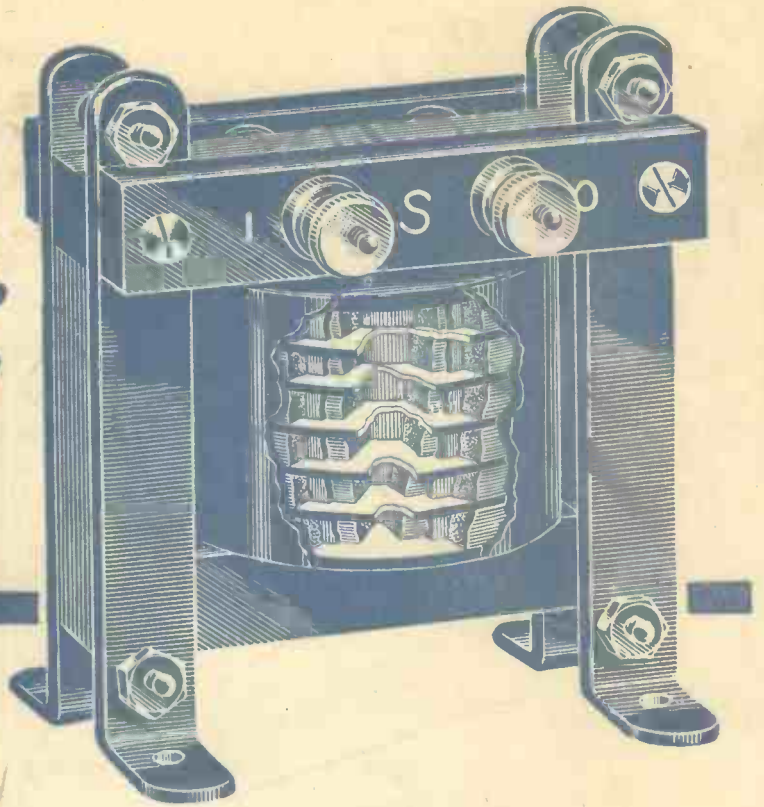

To understand the reason for the extra amplification demonstrated with the R.I. transformer, it must be clearly understood that the secret lies in the peculiar construction of winding the core.

THE SECRET OF R.I. SUPREMACY LIES IN THE WINDING

If you look at the illustration, you will see the sectionalising of the windings, the six primary sections and the six secondary separated by heavy walls of the finest insulation, giving that extremely low self capacity of only

18 MICRO-MICRO FARADS.

This bare minimum self capacity is the basis of

DISTORTIONLESS AMPLIFICATION.

The low self-capacity prevents the exaggeration of the overtones, ensuring uniformity of the high as well as the low frequencies.

No transformer can receive a poor tone and make it sound beautiful. It does not create tones, it amplifies and reproduces them. Its utmost achievement is to amplify and give you from a distance the full depth and volume of perfect music and speech.

Over 350,000 R.I. users have proved for themselves that the R.I. gives

BEAUTIFUL REPRODUCTION.

They would not change the R.I. for any other transformer on the market.

You can be sure of R.I. results if you demand the R.I. TRANSFORMER.

PRICE 25/-

Ask for the new R.I. Catalogue.



12 HYDE ST OXFORD ST LONDON W.C.1

Contractors to the Admiralty and all Government Departments.